

Enzymes

Question Paper 3

Level	IGCSE
Subject	Biology
Exam Board	CIE
Topic	Enzymes
Sub-Topic	
Paper Type	Alternative to Practical
Booklet	Question Paper 3

Time Allowed: 36 minutes

Score: /30

Percentage: /100

- 1 Catalase, an enzyme, is present in all living cells including those of potato and liver. It speeds up the breakdown of hydrogen peroxide as shown by the equation:



The oxygen is given off as a gas which can be collected over water, as shown in Fig. 1.1.

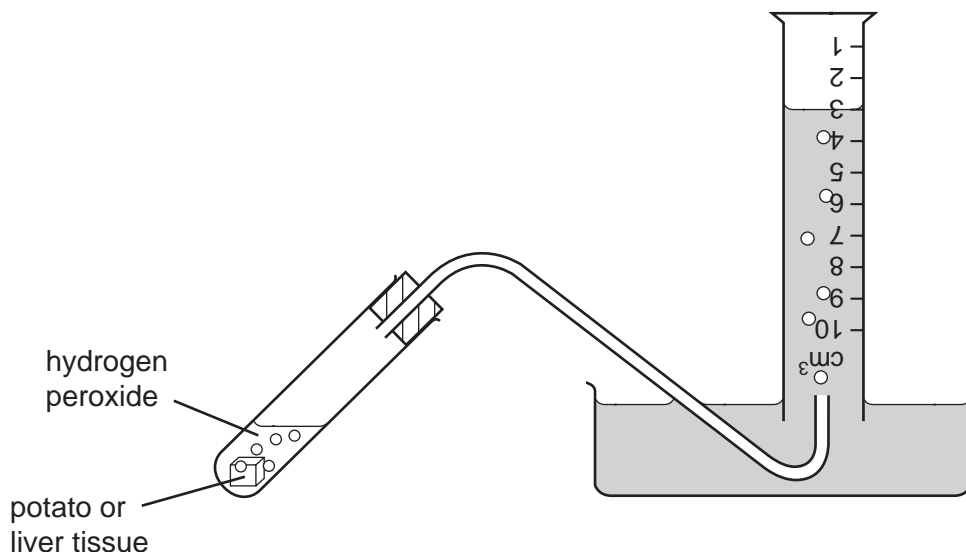



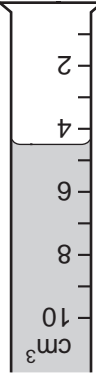
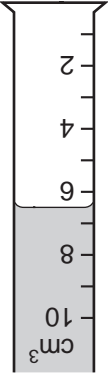
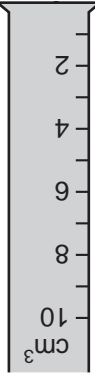
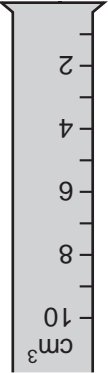
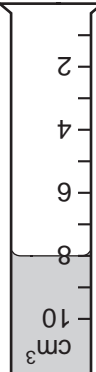
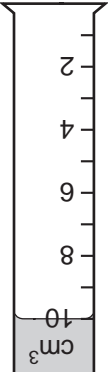
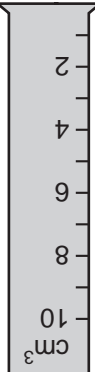
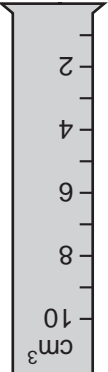

Fig. 1.1

Two different tissues, potato and liver, were used for this investigation. Samples, each of one gram, were prepared from both tissues. Some of the samples were left raw and others were boiled. Some samples were left as one cube and others were chopped into small pieces as shown in Table 1.1 on page 4.

2 cm³ hydrogen peroxide was added to each sample. The volume of oxygen produced in five minutes was collected in the measuring cylinders, as shown in Table 1.1.

Table 1.1

sample	A	B		
treatment	 raw	 raw	 boiled	 boiled
results for potato				
results for liver				

(a) (i) Complete Table 1.2, by reading the values for oxygen collected in the measuring cylinders in Table 1.1.

Table 1.2

tissue	volume of oxygen collected from each sample / cm ³			
	A	B	C	D
potato				
liver				

[2]

(ii) Plot the volumes of oxygen collected from the samples as a bar chart on the grid.

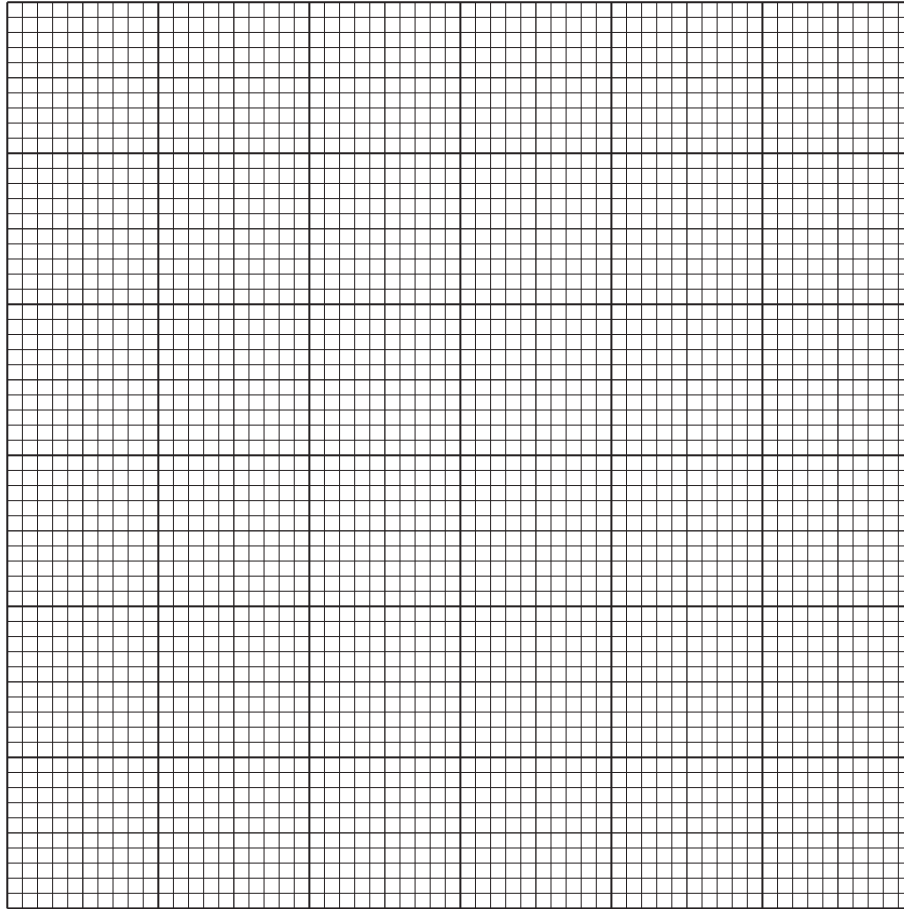

[4]

(iii) Describe the difference in results between sample **A** for potato and sample **A** for liver.

.....

.....

..... [2]

(iv) There is a difference between the samples for **A** and **B** for liver.

Suggest an explanation for this difference.

.....

.....

..... [2]

(b) State the importance of samples **C** and **D** in this investigation.

.....
..... [1]

(c) Suggest how you could test that the gas given off was oxygen.

.....
..... [1]

[Total 12]

- 2 A protein is used to hold other chemicals onto the clear plastic backing of photographic film, as shown in Fig. 1.1.

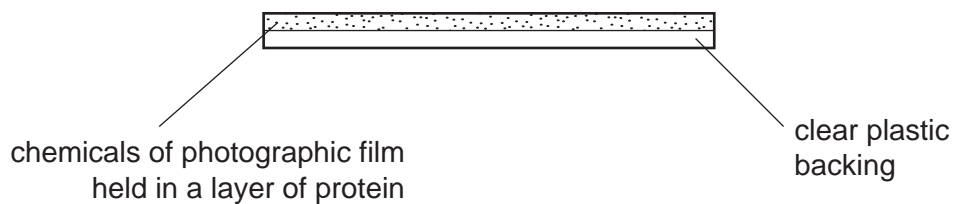

Fig.1.1

Trypsin is an enzyme which will digest the protein so that the coating on the photographic film is removed and the film becomes clear.

Table 1.1 shows the results obtained by two students who investigated the effect of pH on the activity of this enzyme. They made up the solutions, set up the experiment and timed how long the enzyme took to digest the protein and clear the film.

Table 1.1

pH	time for the protein to be digested / mins	
	student 1	student 2
2	12.0	14.0
4	8.0	9.0
6	2.0	3.0
8	0.5	1.0
10	8.0	9.0

(a) (i) Plot the results obtained by **student 2** in the form of a suitable graph.

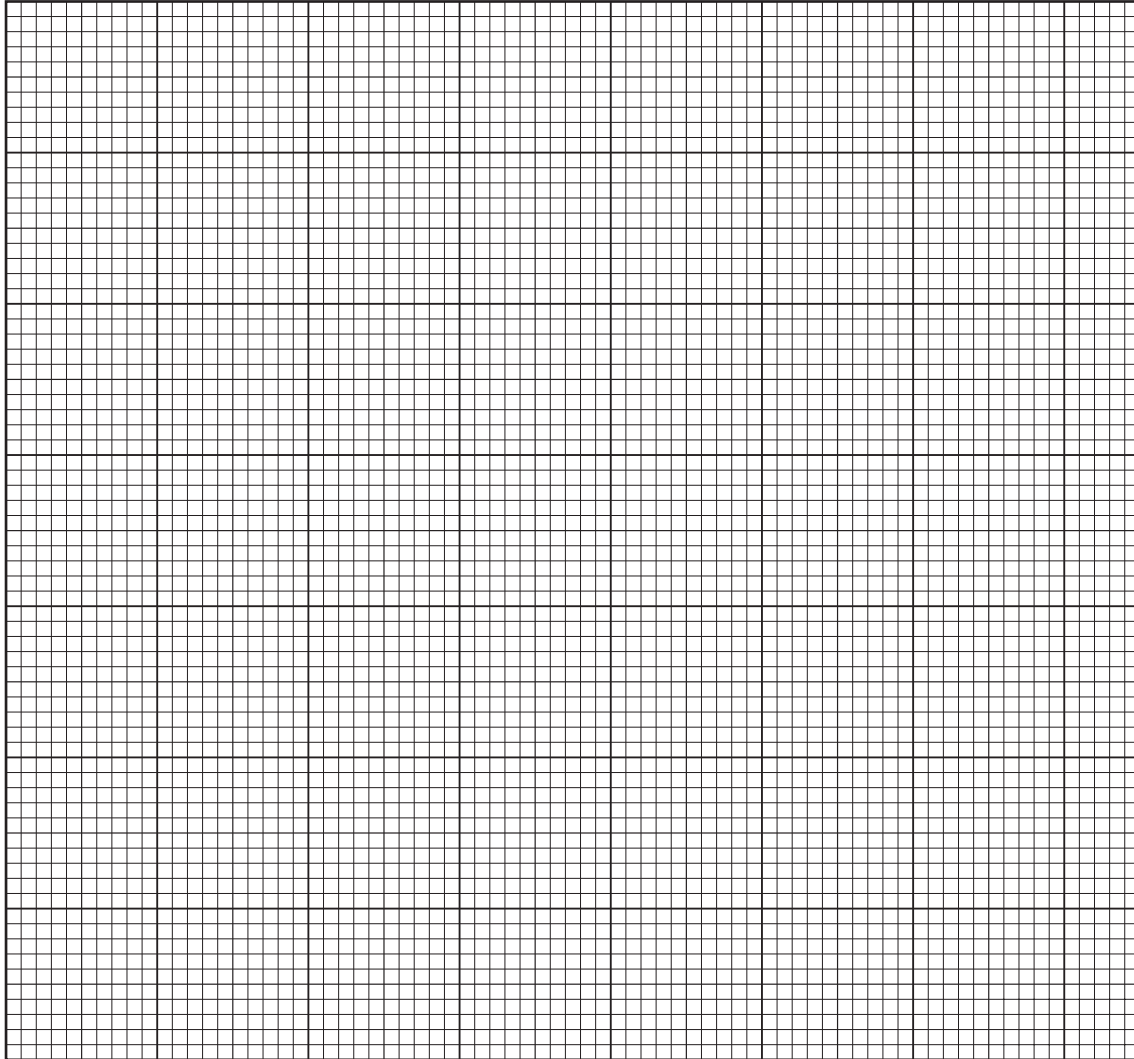

[5]

(ii) Describe and explain the effect of pH on the activity of the enzyme.

.....

.....

.....

.....

.....

.....

.....

.....

.....

[5]

(b) (i) Suggest reasons for the difference in the results for the two students.

.....
.....
..... [3]

(ii) If you were to carry out this investigation, describe what steps you would take to ensure that your results were as reliable and valid as possible.

.....
.....
.....
.....
.....
.....
..... [5]

[Total:18]