

# Electromagnetic Spectrum

## Question Paper 1

Level	IGCSE
Subject	Physics
ExamBoard	CIE
Topic	Properties of Waves including Light and Sound
Sub-Topic	Electromagnetic Spectrum
Paper Type	(Extended) Theory Paper
Booklet	Question Paper 1

**Time Allowed:** 78 minutes

**Score:** /65

**Percentage:** /100

- 1 (a) (i) A ray of light passes through a length of curved optical fibre.

Draw a diagram showing the fibre and the path of the ray of light.

[1]

- (ii) Describe one use of optical fibres in medicine. You may draw a diagram.

.....

.....

.....

.....

.....

.....

.....

[3]

(b) Draw a straight line from each wave on the left to the most appropriate speed.

	90 m/s ( $9 \times 10$ )
light in air	6000 m/s ( $6 \times 10^3$ )
microwaves in a vacuum	100 000 m/s ( $1 \times 10^5$ )
	1 000 000 m/s ( $1 \times 10^6$ )
sound in steel	300 000 000 m/s ( $3 \times 10^8$ )
	60 000 000 000 m/s ( $6 \times 10^{10}$ )

[3]

(c) The refractive index of a block of glass is 1.5.

Use your value for the speed of light from (b) to calculate the speed of light in this block.

speed = ..... [2]

[Total: 9]

- 2 Fig. 6.1 shows a scale drawing of plane wavefronts approaching a gap in a barrier.

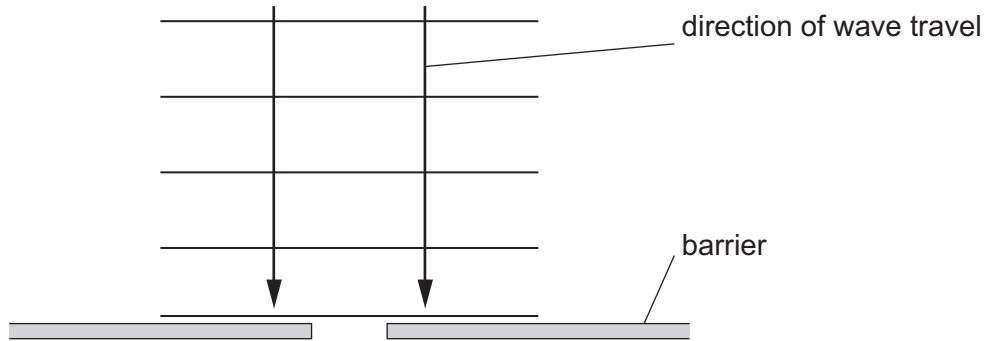

**Fig. 6.1**

- (a) On Fig. 6.1, draw the pattern of the wavefronts after the wave has passed through the gap. [2]

- (b) The wave approaching the barrier has a wavelength of 2.5cm and a speed of 20 cm/s.

Calculate the frequency of the wave.

frequency = ..... [2]

- (c) State what happens, if anything, to the frequency of the wave as it passes through the gap.

..... [1]

- (d) Explain, in terms of diffraction, why a car radio may pick up low frequency radio signals but not pick up high frequency radio signals when the car is travelling behind a hill.

.....

.....

..... [2]

[Total: 7]

3 (a) State the type of electromagnetic radiation

(i) used in luggage security checks at airports,

.....

(ii) used by remote controls for TV sets.

.....

[2]

(b) The electromagnetic waves used in a microwave oven have a frequency of  $2.45 \times 10^9$  Hz. The speed of the waves is  $3.00 \times 10^8$  m/s.

Calculate the wavelength of the waves.

wavelength = ..... [2]

[Total: 4

4 A laser produces a ray of blue light of wavelength  $4.0 \times 10^{-7} \text{ m}$  (0.000 00040 m).

(a) (i) State the speed of light in a vacuum.

speed = ..... [1]

(ii) Calculate the frequency of the light produced by the laser.

frequency = ..... [2]

(b) The ray of blue light passes from air into a glass block. Fig. 6.1 shows the ray making an angle of  $35^\circ$  with the side of the block.

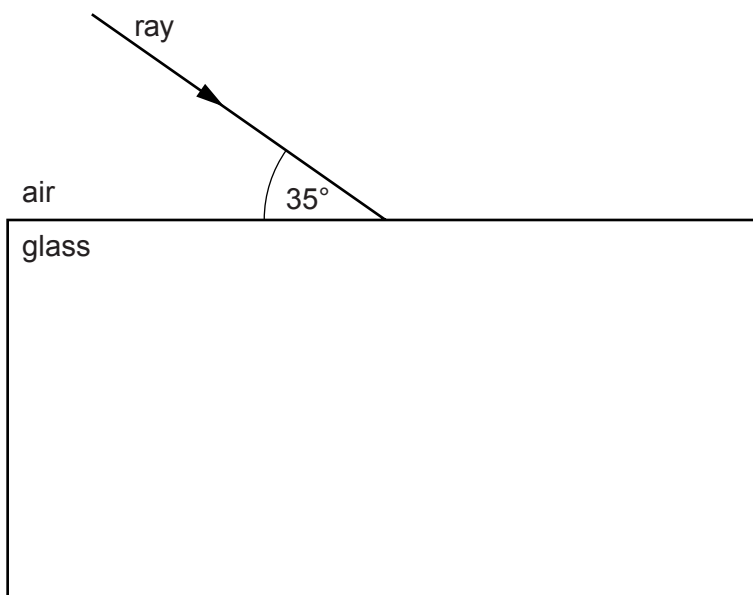

Fig. 6.1

- (i) State the angle of incidence of the ray of blue light on the glass.

angle of incidence = ..... [1]

- (ii) Glass has a refractive index of 1.5.

Calculate the angle of refraction of the light in the glass.

angle of refraction = ..... [2]

[Total: 6]



- 5 (a) Fig. 7.1 shows a ray of monochromatic red light, in air, incident on a glass block at an angle of incidence of  $50^\circ$ .

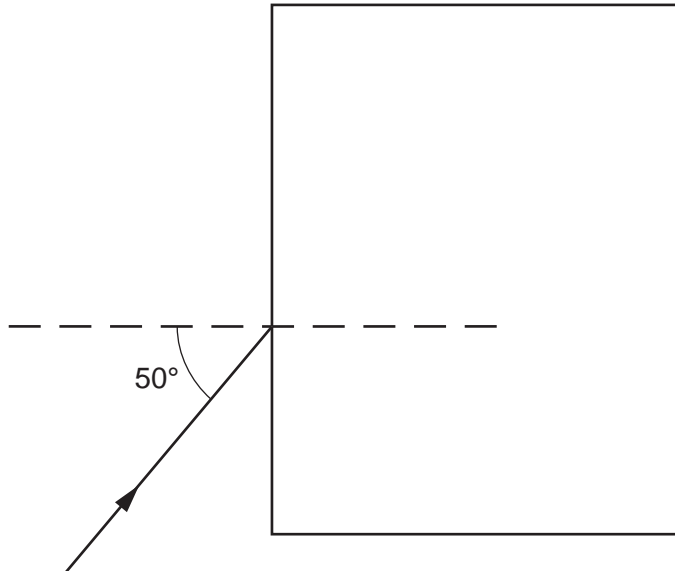

Fig. 7.1

- (i) State what is meant by *monochromatic* light.

.....[1]

- (ii) For this red ray the refractive index of the glass is 1.52. Calculate the angle of refraction for the ray.

angle of refraction = .....[2]

- (iii) Without measuring angles, use a ruler to draw the approximate path of the ray in the glass block and emerging from the block. [2]

(b) The red ray in Fig. 7.1 is replaced by a ray of monochromatic violet light. For this violet ray the refractive index of the glass is 1.54. The speed of light in air is  $3.00 \times 10^8$  m/s.

(i) Calculate the speed of the violet light in the glass block.

speed = .....[2]

(ii) Use a ruler to draw the approximate path of this violet ray in the glass block and emerging from the block. Make sure this path is separated from the path drawn for the red light in (a)(iii). Mark both parts of this path with the letter V. [2]

[Total: 9]

6 (a) The following list contains the names of types of energy transfer by means of waves.

$\gamma$ -rays, infra-red, radio/TV/microwaves, sound, visible light, X-rays

(i) Which one of these is **not** a type of electromagnetic wave?

..... [1]

(ii) State the nature of the wave you have named in (a)(i).

..... [1]

(iii) The remaining names in the list are all regions of the electromagnetic spectrum, but one region is missing.

Name the missing region.

..... [1]

(b) A television station emits waves with a frequency of  $2.5 \times 10^8$  Hz. Electromagnetic waves travel at a speed of  $3.0 \times 10^8$  m/s.

Calculate the wavelength of the waves emitted by this television station. State the equation you use.

wavelength = ..... [3]

[Total: 6]

- 7 Fig. 6.1 shows white light incident at P on a glass prism. Only the refracted red ray PQ is shown in the prism.

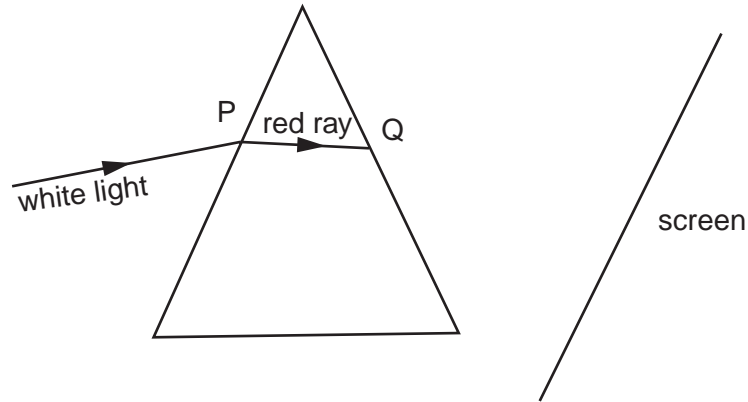

Fig. 6.1

- (a) On Fig. 6.1, draw rays to complete the path of the red ray and the whole path of the violet ray up to the point where they hit the screen. Label the violet ray. [3]
- (b) The angle of incidence of the white light is increased to  $40^\circ$ . The refractive index of the glass for the red light is 1.52.  
Calculate the angle of refraction at P for the red light.

angle of refraction = .....[3]

- (c) State the approximate speed of

(i) the white light incident at P,

speed = .....[1]

(ii) the red light after it leaves the prism at Q.

speed = .....[1]

[Total : 8]

8 Fig. 7.1 shows the parts of the electromagnetic spectrum.

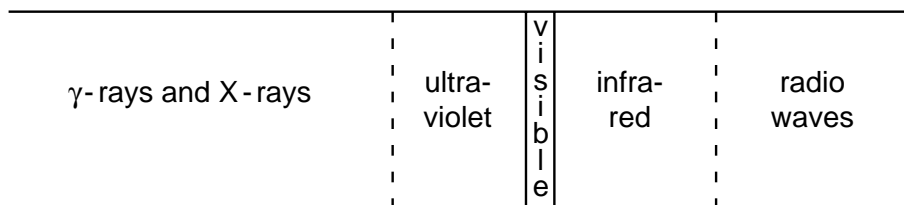

Fig. 7.1

(a) Name one type of radiation that has

(i) a higher frequency than ultra-violet,

..... [1]

(ii) a longer wavelength than visible light.

..... [1]

(b) Some  $\gamma$ -rays emitted from a radioactive source have a speed in air of  $3.0 \times 10^8$  m/s and a wavelength of  $1.0 \times 10^{-12}$  m.

Calculate the frequency of the  $\gamma$ -rays.

frequency = ..... [2]

(c) State the approximate speed of infra-red waves in air.

..... [1]

9 Fig. 6.1 shows an optical fibre. XY is a ray of light passing along the fibre.

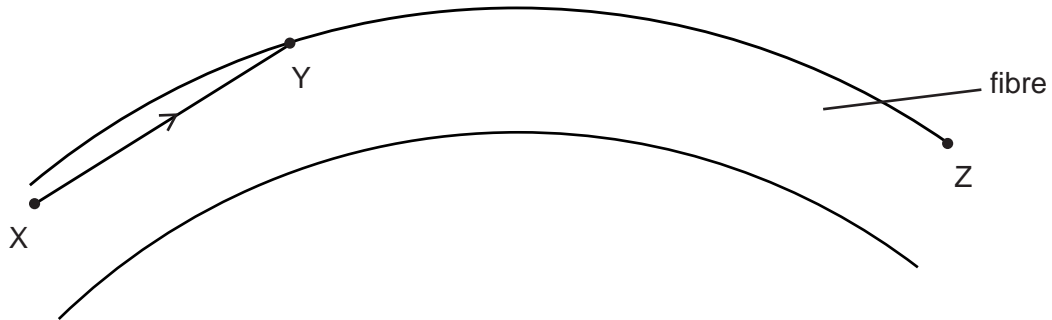

Fig. 6.1

(a) On Fig. 6.1, continue the ray XY until it passes Z. [1]

(b) Explain why the ray does **not** leave the fibre at Y.

.....  
 .....  
 .....[2]

(c) The light in the optical fibre has a wavelength of  $3.2 \times 10^{-7}$  m and is travelling at a speed of  $1.9 \times 10^8$  m/s.

(i) Calculate the frequency of the light.

frequency = .....

(ii) The speed of light in air is  $3.0 \times 10^8$  m/s.  
 Calculate the refractive index of the material from which the fibre is made.

refractive index = .....

[Total : 7] [4]