

The Nuclear atom

Question Paper 2

Level	IGCSE
Subject	Physics
ExamBoard	CIE
Topic	Atomic Physics
Sub-Topic	The nuclear atom
Paper Type	(Extended) Theory Paper
Booklet	Question Paper 2

Time Allowed: 74 minutes

Score: /62

Percentage: /100

- 1 Strontium-90 is a radioactive isotope that emits β -particles as it decays. The nuclear equation below shows this decay.

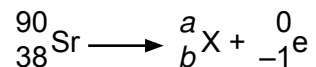

(a) Calculate

- (i) the value of a ,

$a = \dots\dots\dots$

- (ii) the value of b .

$b = \dots\dots\dots$

[2]

(b) (i) Tick the element from the list below that is produced by this decay.

element	proton number	place one tick in this column
selenium	34	
bromine	35	
krypton	36	
rubidium	37	
strontium	38	
yttrium	39	
zirconium	40	
niobium	41	
molybdenum	42	

[1]

- (ii) The isotope ${}_b^a\text{X}$ is also radioactive and undergoes β -decay.

State the name of the element that is produced by this decay.

$\dots\dots\dots$ [1]

(c) Three nuclei are represented as

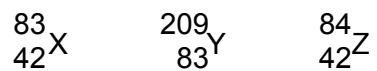

State and explain which nuclei are isotopes of the same element.

.....

.....

.....

..... [2]

[Total: 6]

- 2 Fig. 9.1 shows an experiment carried out **in a vacuum** to investigate the deflection of α -particles and γ -rays in a magnetic field.

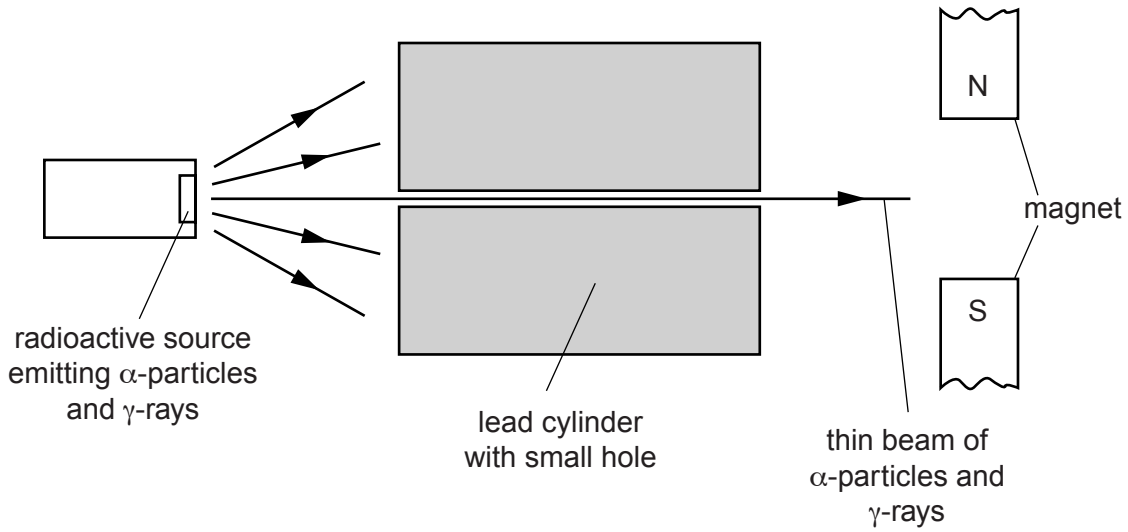

Fig. 9.1

- (a) Complete the table to describe the deflection, if any, of the α -particles and the γ -rays in the magnetic field shown. Place **one** tick in **each** column.

possible deflection	α -particles	γ -rays
no deflection		
towards N pole of magnet		
towards S pole of magnet		
out of paper		
into paper		

[3]

(b) The experiment of Fig. 9.1 was carried out in a vacuum.

State the effect of carrying out the experiment in air.

.....
.....
..... [2]

(c) State and explain the purpose of the lead cylinder.

.....
.....
..... [2]

[Total: 7]

3 The isotope thorium-234 is radioactive. It emits β -particles as it decays.

(a) The incomplete nuclide equation represents the decay of thorium-234 to an isotope of protactinium (Pa).

Complete the equation.

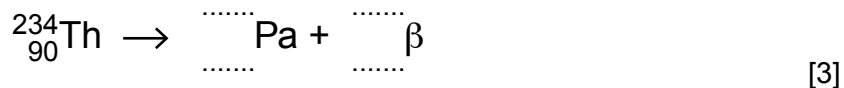

(b) Fig. 11.1 shows a beam of β -particles from a sample of thorium-234 passing into the electric field between two charged plates in a vacuum.

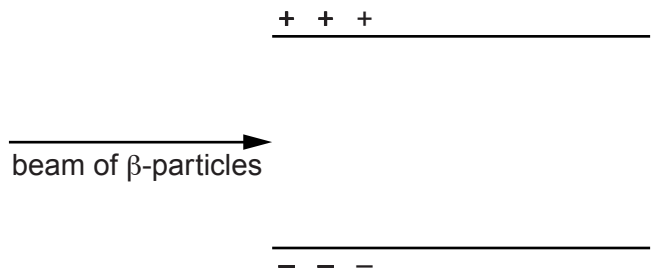

Fig. 11.1

(i) By drawing on Fig. 11.1, show how the β -particles move as they pass between the plates. [1]

(ii) Explain why the β -particles move in this way.

.....
 [1]

[Total: 5]

4 The most abundant stable isotope of strontium is strontium-88. Its nucleon number is 88 and its proton number is 38. In nuclide notation it is written ${}^x_y\text{Sr}$.

(a) Write down

(i) the values of x and y for strontium-88, x =

y =

(ii) the number of neutrons in a nucleus of strontium-88,

(iii) the number of electrons in a neutral atom of strontium-88.

[3]

(b) Strontium-90 is a radioactive isotope produced by nuclear reactions. State how the structure of this isotope differs from that of strontium-88.

.....

.....

.....

.....

.....

..... [2]

[Total: 5]

- 5 (a) In a laboratory's secure radioactivity cupboard are two unlabelled radioactive sources. A scientist knows that one is an alpha-emitter and the other is a beta-emitter, but is not sure which is which.

A radiation detector, a magnet and some paper are available.

Briefly describe two different experimental tests, using this equipment, which would allow the scientist to identify which is the alpha-emitter and which is the beta-emitter.

test	outcome for alpha	outcome for beta

[4]

(b) Radioactive carbon-14 ($^{14}_6\text{C}$) decays by emitting β -particles.

(i) What are the values of the proton and nucleon numbers of carbon-14?

proton number

nucleon number[2]

(ii) Carbon-14 is absorbed by living organisms. When the organism dies, no more carbon-14 is absorbed. The carbon-14 already absorbed decays with a half-life of 5730 years.

Recent human skeletons have an activity of 64 units, but a human skeleton dug up by an archaeologist has an activity of 8 units.

Determine the age of this ancient skeleton.

age =[2]

[Total: 8]

6 A certain element is known to exist as two different isotopes.

(a) State one thing that is the same for atoms of both isotopes.

..... [1]

(b) State one thing that is different between atoms of these two isotopes.

..... [1]

(c) An atom of one of these isotopes is unstable and decays into a different element by emitting a β -particle.

(i) State one thing about the atom that remains the same during this decay.

..... [1]

(ii) State one thing about the atom that changes as a result of this decay.

..... [1]

[Total: 4]

- 7 A student is using a cathode-ray oscilloscope to display the waveform of an alternating current supply. The arrangement is shown in Fig. 10.1.

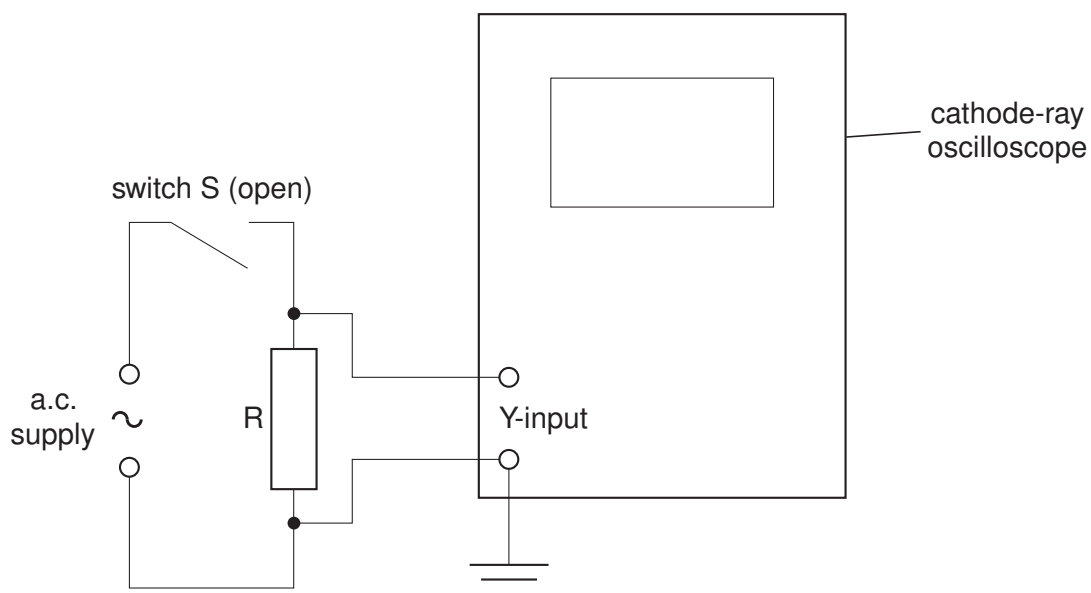

Fig. 10.1

When switch S is closed, the trace seen on the screen is as shown in Fig. 10.2. To get this trace, the settings of the oscilloscope controls are

volts/cm: 5V/cm

time-base: 10 ms/cm

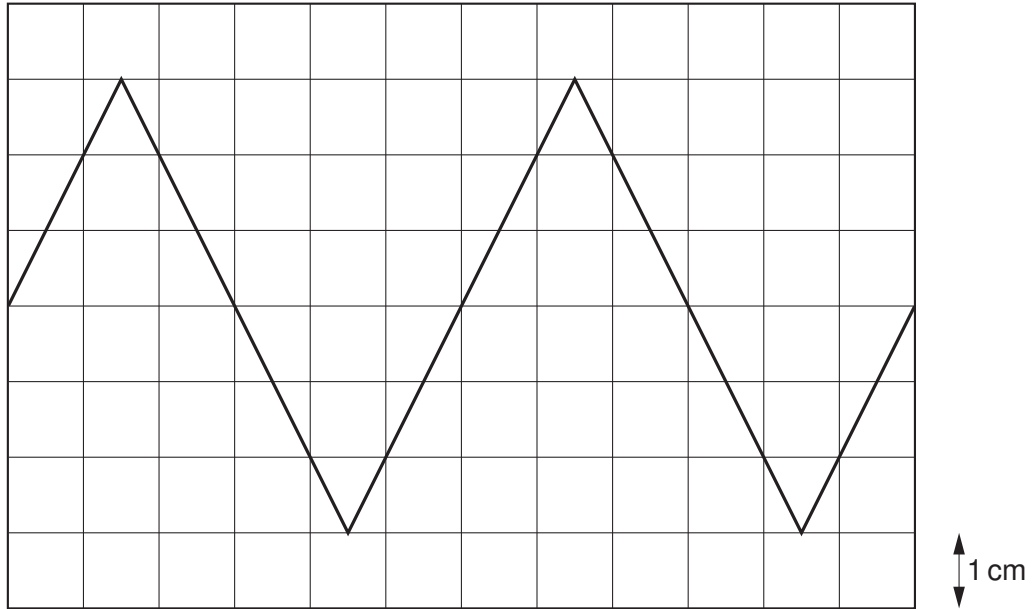

Fig. 10.2

(a) On Fig. 10.2, carefully draw what is seen on the screen when the frequency of the supply is increased to 1.5 times its previous value. [3]

(b) What change, if any, must be made to the oscilloscope volts/cm and time-base controls in order to reduce the peak-to-peak height of the trace to half that shown in Fig. 10.2?

volts/cm setting [2]

time-base setting [1]

[Total: 6]

- 8 In Geiger and Marsden's α -particle scattering experiment, α -particles were directed at a very thin gold foil.

Fig. 10.1 shows five of the nuclei of the atoms in one layer in the gold foil. Also shown are the paths of three α -particles directed at the foil.

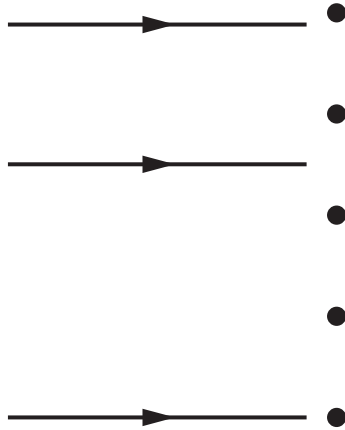

Fig. 10.1

- (a) On Fig.10.1, complete the paths of the three α -particles. [3]

- (b) (i) What result of the experiment confirmed that an atom consisted of a very tiny charged core, containing almost all the mass of the atom?

.....
..... [1]

- (ii) What is the sign of the charge on this core? [1]

- (iii) What occupies the space between these charged cores?
..... [1]

[Total: 6]

1 An atom of one of the isotopes of sodium contains

11 protons, 11 electrons and 13 neutrons.

(a) Underline which of these three will be the same in neutral atoms of all isotopes of sodium. [2]

(b) State the nucleon number of this isotope. [1]

(c) What can you say about the chemical properties of the different isotopes of sodium?
..... [1]

(d) One isotope of sodium is ^{25}Na .
How many neutrons are there in one atom of this isotope? [1]

[Total: 5]

- 2 (a) Chlorine has two isotopes, one of nucleon number 35 and one of nucleon number 37. The proton number of chlorine is 17.

Table 11.1 refers to neutral atoms of chlorine.

Complete Table 11.1.

	nucleon number 35	nucleon number 37
number of protons		
number of neutrons		
number of electrons		

Table 11.1

[3]

- (b) Some isotopes are radioactive.

State the three types of radiation that may be emitted from radioactive isotopes.

1.
2.
3.

[1]

- (c) (i) State one practical use of a radioactive isotope.

.....
..... [1]

- (ii) Outline how it is used.

.....
.....
.....
.....
..... [1]

[Total: 6]

3 (a) α - particles can be scattered by thin gold foils.

Fig. 11.1 shows part of the paths of three α -particles.
Complete the paths of the three α -particles.

[3]

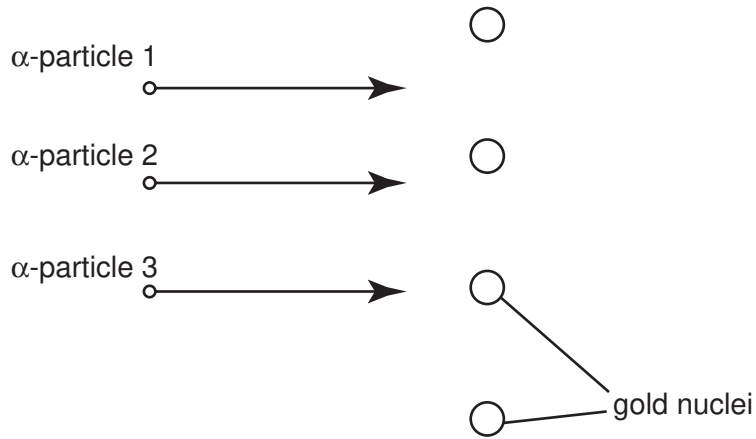

Fig. 11.1

(b) What does the scattering of α -particles show about atomic structure?

.....
.....
.....[2]

(c) State the nucleon number (mass number) of an α -particle.

nucleon number =[1]