

Mass and Weight

Question Paper

Level	IGCSE
Subject	Physics
Exam Board	CIE
Topic	General Physics
Sub-Topic	Mass and Weight
Paper Type	Alternative to Practical
Booklet	Question Paper

Time Allowed: 57 minutes

Score: /47

Percentage: /100

- 1 A student is using a forcemeter and a set of different loads to determine the weight of a metre rule. She is using the apparatus shown in Fig. 2.1.

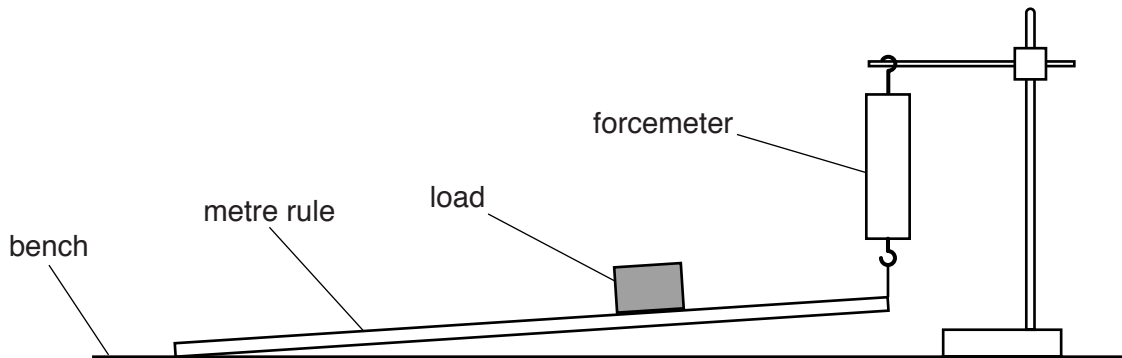

Fig. 2.1

- (a) Fig. 2.2 shows the position of the load on the metre rule. The load is always at this position on the rule.

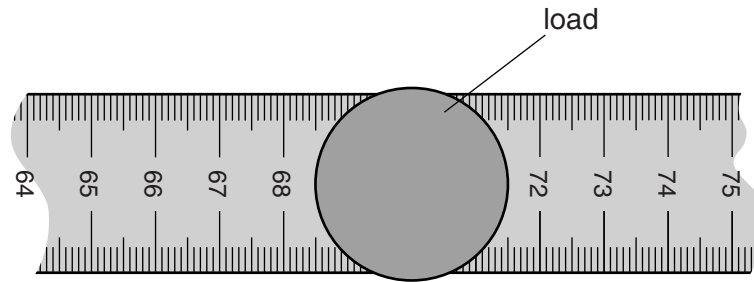

Fig. 2.2 (not full size)

Determine the scale reading on the metre rule at which the centre of the load is located. Show your working.

scale reading = cm [2]

- (b) The student measures the force F indicated by the forcemeter for different loads placed on the rule.

Figs. 2.3 (a)–(e) show the scale of the forcemeter for values of load $L = 1.00\text{ N}$, 2.00 N , 3.00 N , 4.00 N and 5.00 N .

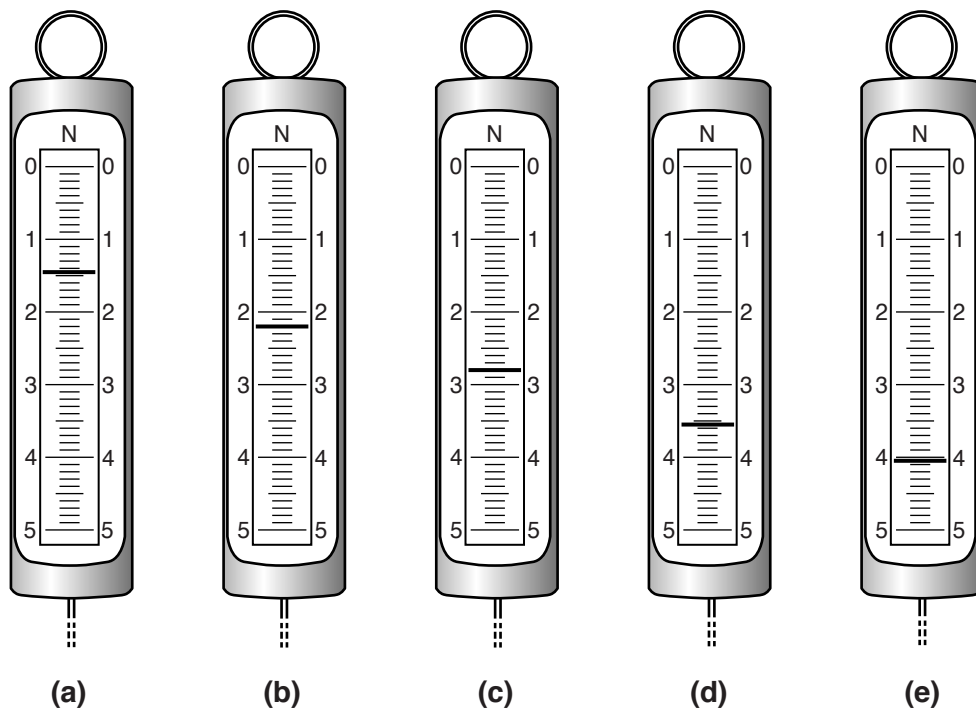

Fig. 2.3

In Table 2.1, record the value of F for each load.

Table 2.1

L/N	F/N
1.00	
2.00	
3.00	
4.00	
5.00	

(c) Plot a graph of F/N (y -axis) against L/N (x -axis). Start your graph at the origin (0,0).

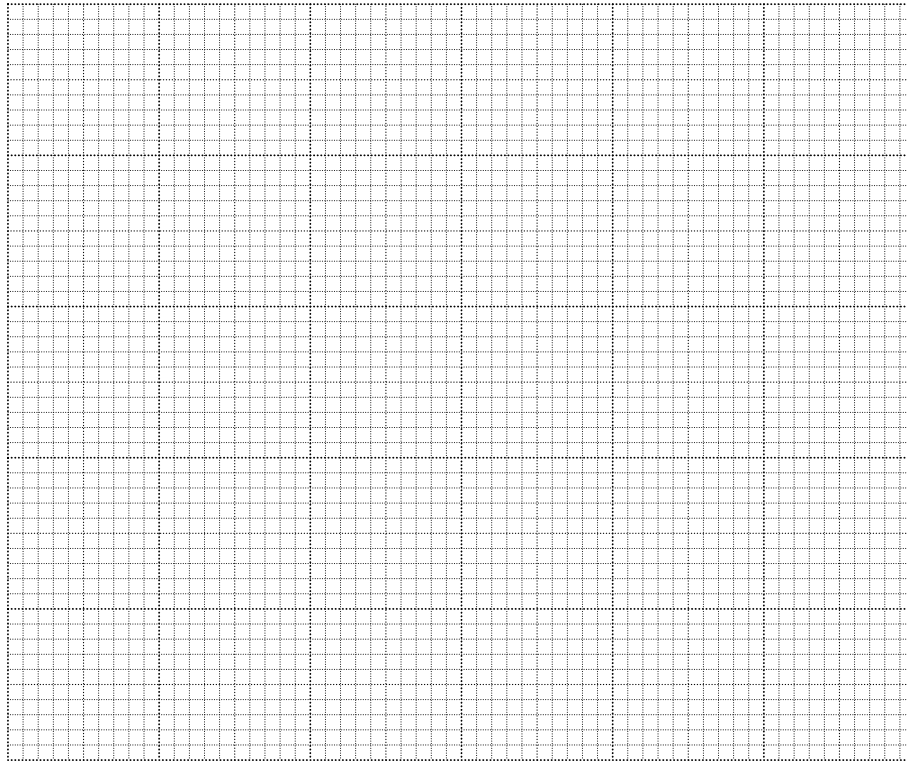

[4]

(d) (i) Determine the value y of the intercept of the line on the F axis.

$y = \dots\dots\dots$ [1]

(ii) The weight W of the metre rule is numerically equal to $2y$.

Write down a value for W to a suitable number of significant figures for this experiment.

$W = \dots\dots\dots$ [2]

(e) Assuming that the procedure is carried out carefully, suggest a possible source of inaccuracy in this experiment.

.....
.....
.....[1]

[Total: 12]

2 A student is determining the weight of a metre rule using a balancing method.

The apparatus is shown in Fig. 1.1.

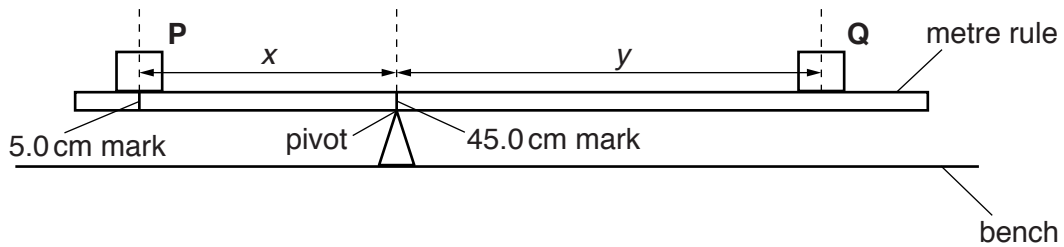

Fig. 1.1 (not to scale)

- (a)
- The student places the load **P** on the metre rule at the 5.0 cm mark.
 - She places the metre rule on the pivot at the 45.0 cm mark.
 - She places load **Q** on the rule and adjusts its position so that the metre rule is as near as possible to being balanced.
 - She measures the distance x between the centre of load **P** and the pivot and the distance y from the centre of load **Q** to the pivot.
 - She repeats the procedure, placing the load **P** at the 10.0 cm mark, at the 15.0 cm mark, at the 20.0 cm mark and at the 25.0 cm mark. The readings are shown in Table 1.1.

Table 1.1

$x/$	$y/$	$A/$	$B/$
40.0	42.5		
35.0	36.0		
30.0	30.0		
25.0	24.0		
20.0	17.5		

- (i)
- For each value of x , calculate $A = Px$, where $P = 1.00\text{ N}$. Record the values in the table. P is the weight of load **P**.
 - For each value of y , calculate $B = Qy$, where $Q = 0.80\text{ N}$. Record the values in the table. Q is the weight of load **Q**.

[1]

- (ii) Complete the column headings in the table.

[1]

(b) Plot a graph of A/Ncm (y -axis) against B/Ncm (x -axis). Start both axes at the origin (0,0).

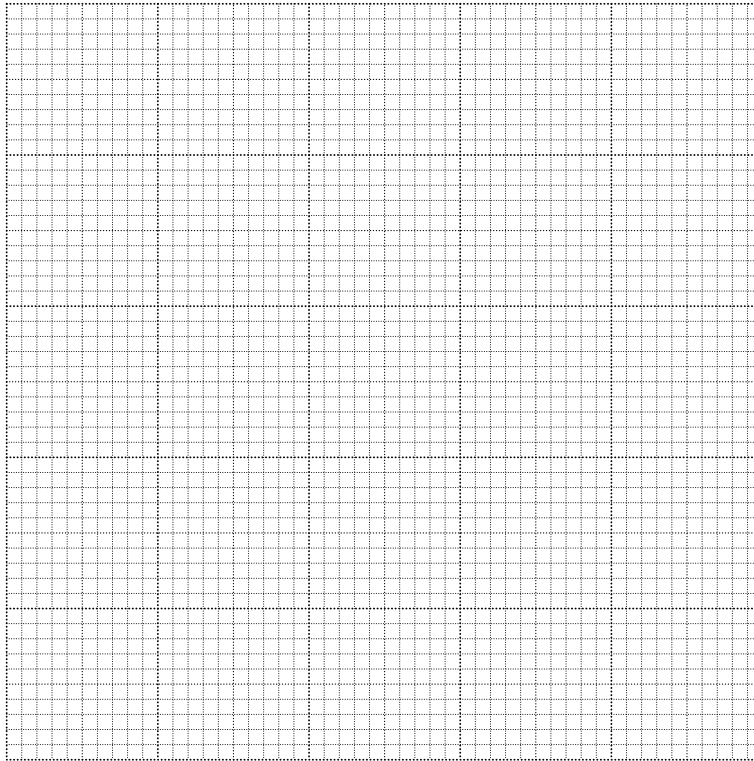

[4]

(c) Using the graph, determine the vertical intercept Y (the value of A when $B = 0\text{Ncm}$). Show clearly on the graph how you obtained this value.

$Y = \dots\dots\dots$ [1]

(d) Calculate the weight W of the metre rule using the equation $W = \frac{Y}{z}$, where $z = 5.0\text{cm}$.

$W = \dots\dots\dots$ [1]

(e) Suggest one practical reason why it is difficult to obtain exact results with this experiment.

.....
..... [1]

- (f) The student uses an accurate electronic balance to obtain a second value for the weight of the metre rule.

weight obtained on the balance = 1.24 N

State and explain whether the two values for the weight agree within the limits of experimental accuracy.

statement

justification

..... [1]

[Total: 10]

3 A student is investigating the stretching of a spring.

The apparatus is shown in Fig. 1.1.

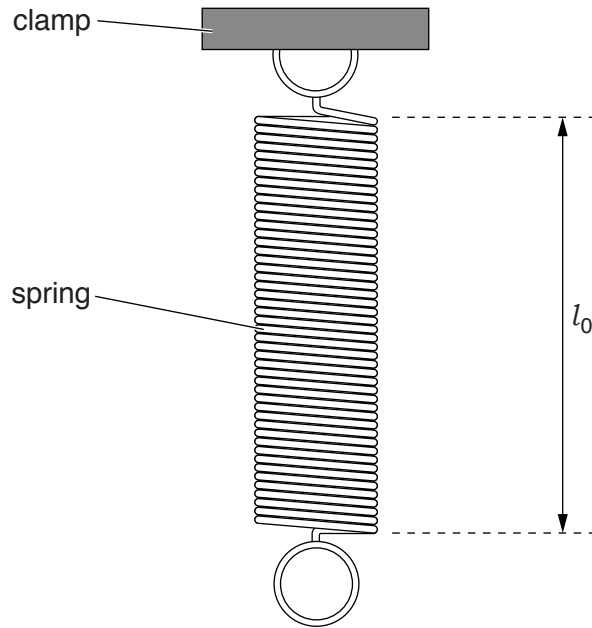

Fig. 1.1

- (a) On Fig. 1.1, measure the unstretched length l_0 of the spring. Record l_0 in the first row of Table 1.1. [1]
- (b) The student hangs a load L of 1.0N on the spring and measures the new length l of the spring. She repeats the measurements using loads of 2.0N, 3.0N, 4.0N and 5.0N. The readings are shown in Table 1.1.
- (i) For each set of readings, calculate the extension e of the spring using the equation $e = (l - l_0)$. Record the values of e in the table.

Table 1.1

L/N	l/mm	e/mm
0.0		0
1.0	59	
2.0	64	
3.0	69	
4.0	74	
5.0	78	

[1]

- (ii) Explain briefly one precaution that you would take in order to obtain reliable readings.

.....

.....[1]

(c) Plot a graph of e/mm (y -axis) against L/N (x -axis).

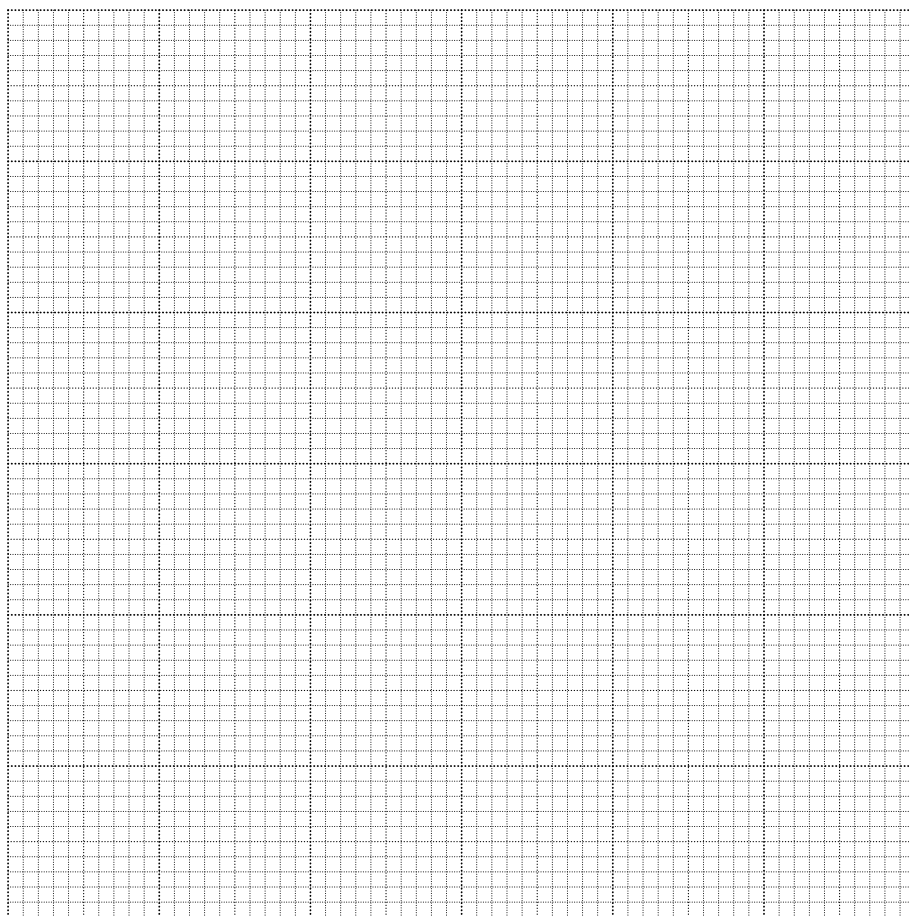

[4]

(d) The student removes the load from the spring and hangs an unknown load **X** on the spring. She measures the length l of the spring.

$$l = \dots\dots\dots 72\text{mm}$$

(i) Calculate the extension e of the spring.

$$e = \dots\dots\dots [1]$$

(ii) Use the graph to determine the weight W of the load **X**. Show clearly on the graph how you obtained the necessary information.

$$W = \dots\dots\dots [2]$$

[Total: 10]

- 4 A student is using a balancing method to determine the weight of a piece of soft modelling clay. The apparatus is shown in Fig. 2.1.

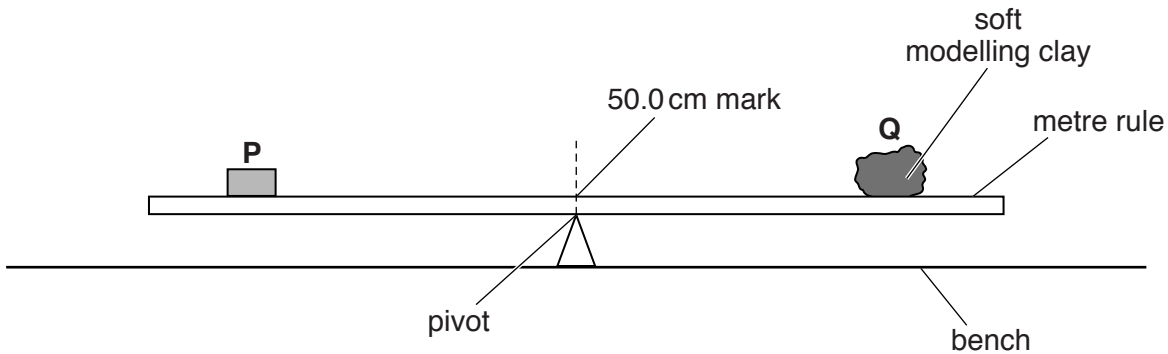

Fig. 2.1

P is a metal cube of weight $P = 1.0\text{ N}$. **Q** is the piece of soft modelling clay.

The student places the cube **P** so that its weight acts at a distance x from the pivot.

He adjusts the position of **Q** to balance the rule and measures the distance y from the centre of **Q** to the pivot. He calculates the weight W of **Q** using the equation $W = \frac{Px}{y}$.

- (a) On Fig. 2.1, mark clearly the distance x . [1]

- (b) Suggest a change to **Q** that would make it easier to find the value of y accurately.

[1]

- (c) It is difficult to achieve an exact balance of the metre rule in this type of experiment. This can make the result unreliable.

Explain how you would reduce the effect of this problem to improve the reliability of the experiment.

[1]

(d) The metal cube **P** is larger than the width of the metre rule.

Explain briefly how you would determine the reading of the metre rule scale at the position of the centre of mass of **P**. You may draw a diagram.

.....
.....
.....[2]

(e) Before starting the experiment, the student determines the position of the centre of mass of the metre rule.

Explain briefly how you would do this.

.....
.....[1]

[Total: 6]

5 The class is determining the mass of an object using two strings.

The apparatus is set up as shown in Fig. 1.1.

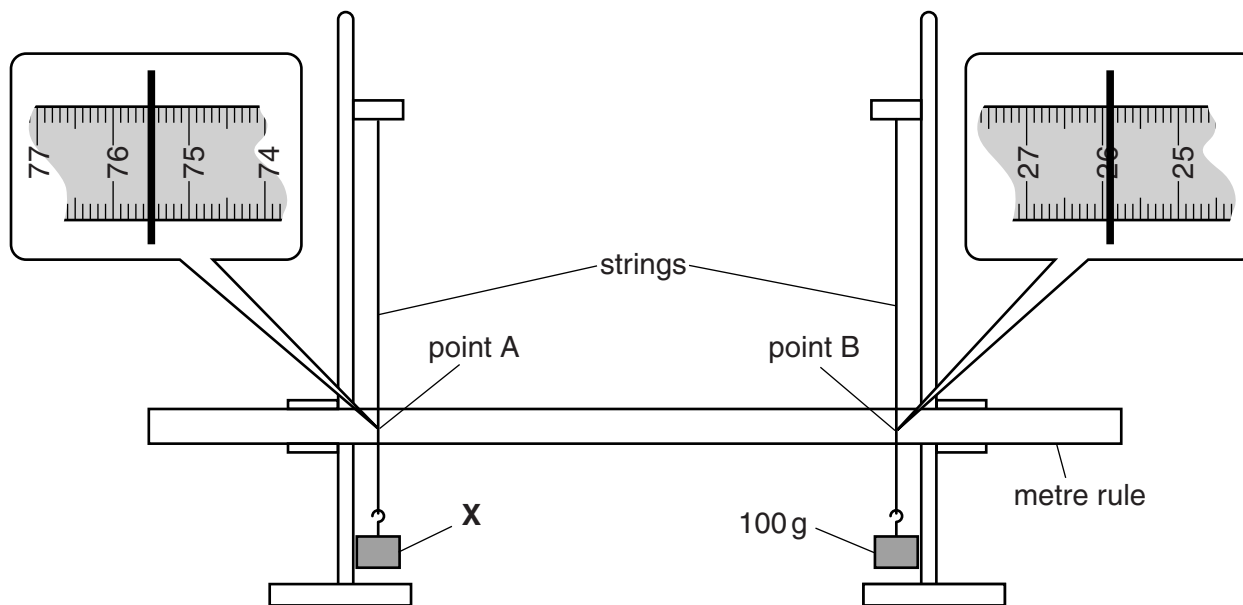

Fig. 1.1

(a) (i) Record the scale reading a_0 at point A, where the string crosses the rule, as indicated in the enlarged section of Fig. 1.1.

$a_0 = \dots\dots\dots$

(ii) Record the scale reading b_0 at point B.

$b_0 = \dots\dots\dots$

[2]

- (b) A loop of string is placed around the vertical strings so that they are pulled closer together, as shown in Fig. 1.2. The loop is horizontal and is just above the rule.

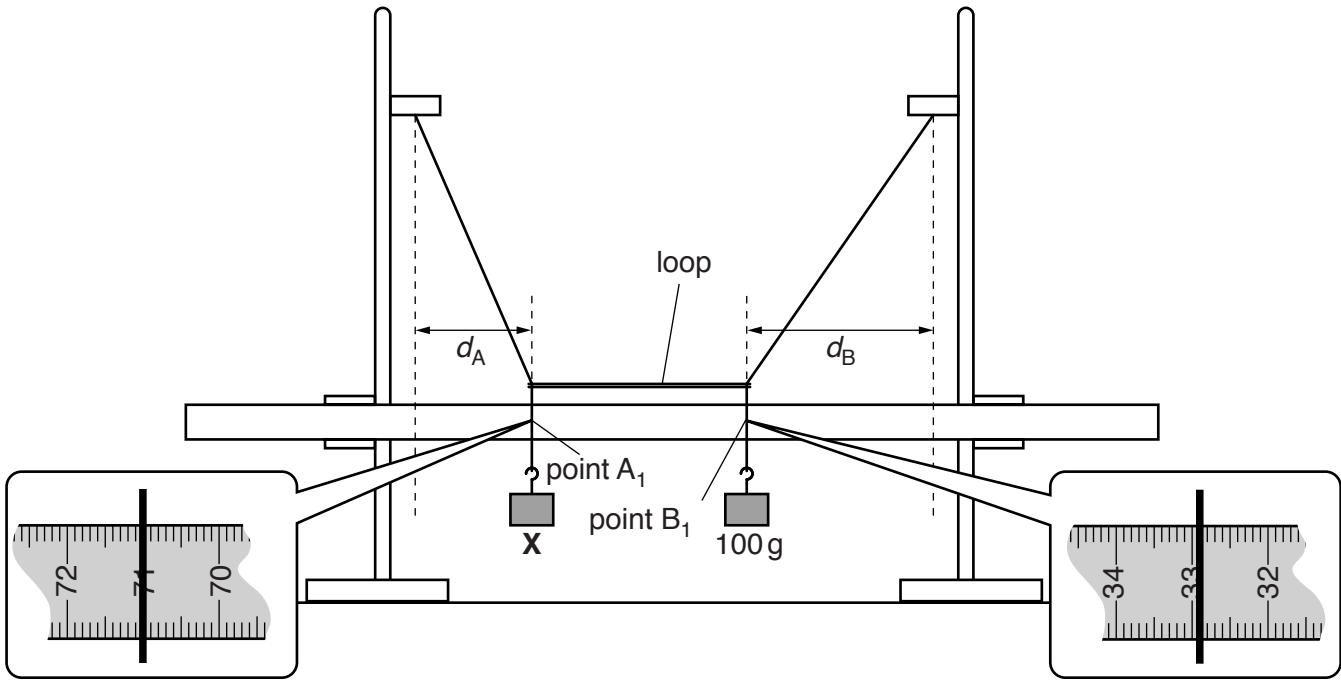

Fig. 1.2

- (i) Record the scale reading a_1 at point A_1 as indicated in the enlarged section of Fig. 1.2.

$a_1 = \dots\dots\dots$

- (ii) Record the scale reading b_1 at point B_1 .

$b_1 = \dots\dots\dots$

[1]

- (iii) Calculate and record the distance d_A , shown in Fig. 1.2. Use your results from (a)(i) and (b)(i). d_A is the difference between a_0 and a_1 .

$d_A = \dots\dots\dots$

- (iv) Calculate and record the distance d_B . Use your results from (a)(ii) and (b)(ii). d_B is the difference between b_1 and b_0 .

$d_B = \dots\dots\dots$

[1]

- (c) Calculate the mass M of object X , using your results from (b)(iii) and (b)(iv) and the equation

$$M = \frac{k d_B}{d_A} \text{ where } k = 100 \text{ g.}$$

$M = \dots\dots\dots$ [2]

(d) Explain how you could ensure that the loop is horizontal in (b). You may draw a diagram.

.....
.....
.....[1]

(e) A student suggests that d_A and d_B might be directly proportional to each other.

Briefly describe how this experiment could be extended to investigate the suggestion.

.....
.....
.....[2]

[Total: 9]