

Thermal Processes

Question Paper 2

Level	IGCSE
Subject	Physics
Exam Board	CIE
Topic	Thermal Physics
Sub-Topic	Thermal Processes
Paper Type	Alternative to Practical
Booklet	Question Paper 2

Time Allowed: 54 minutes

Score: /45

Percentage: /100

- 1 Some IGCSE students have been asked to investigate how different surfaces absorb thermal radiation.

The apparatus is set up as shown in Fig. 2.1, with a piece of white card in close contact with the thermometer bulb.

The distance between the card and the lamp is 1.0 cm.

Fig. 2.1 shows the reading on the thermometer before the lamp is switched on.

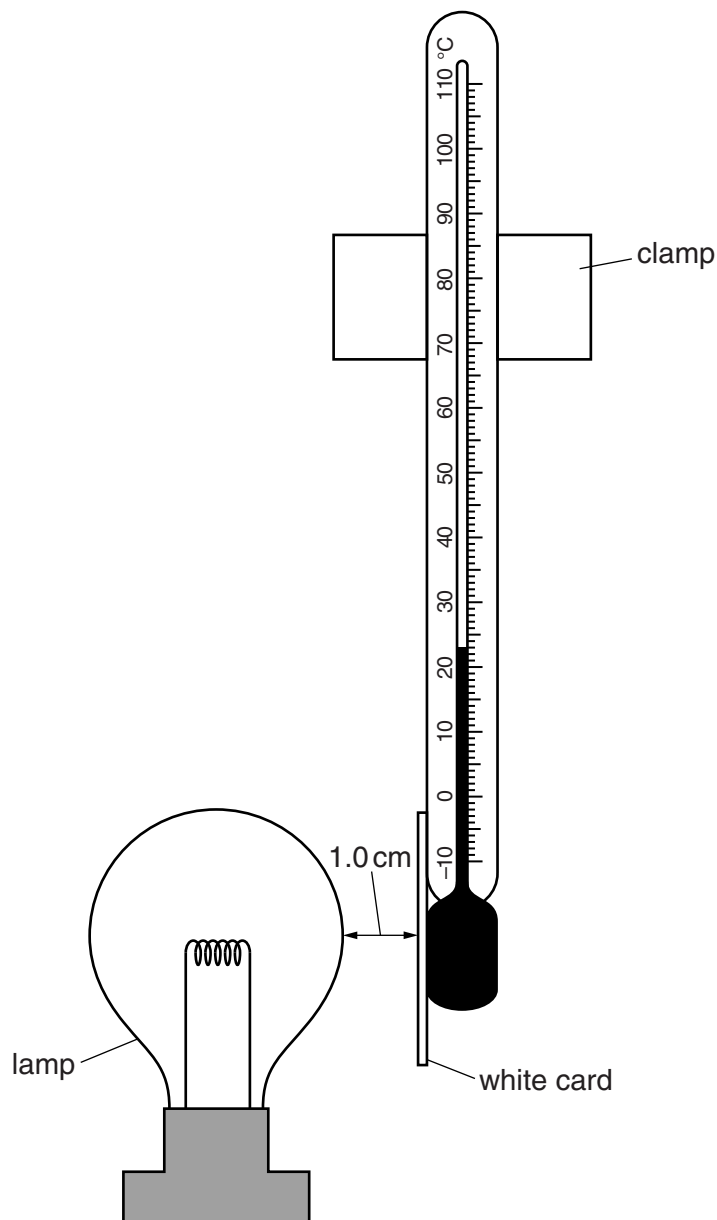

Fig. 2.1

- (a) In Table 2.1, record the temperature before the lamp is switched on, as shown in Fig. 2.1.
- (b) The lamp is switched on and the temperature recorded every minute.

After 300s, the lamp is switched off and the white card is replaced with a piece of black card.

The lamp is then switched on for a further 300s, and the temperature recorded every minute.

Table 2.1 shows the readings obtained during the experiment.

- (i) Complete the column headings in the table.

Table 2.1

	white card	black card
<i>t</i> /	<i>θ</i> /	<i>θ</i> /
0		24
60	25	30
120	28	37
180	30	42
240	32	45
300	33	47

[2]

- (ii) Calculate the overall temperature change for each card after 300 s.

white card: temperature change =

black card: temperature change =

[1]

- (iii) Determine which surface, white or black, absorbs thermal radiation more efficiently. State the experimental evidence for your choice.

surface.....

evidence

.....

[1]

- (iv) A student suggests that the rate of temperature rise will be greater at the beginning of the experiment than towards the end of the experiment.

State whether the results support this. Justify your answer with reference to the data for black card.

statement

justification

.....

.....

[2]

(c) Another IGCSE student wants to repeat the experiment.

Suggest one precaution which she should take with the apparatus to make the comparison between white and black surfaces a fair one. Explain why not taking this precaution might cause the test to be unfair.

precaution

explanation

.....

.....

[2]

[Total: 8]

- 2 A student is investigating the effect of insulation on the rate of cooling of hot water in a 250 cm³ container.

The student can choose from the following apparatus:

- thermometer
- 250 cm³ glass beaker
- 250 cm³ plastic beaker
- 250 cm³ copper can
- 250 cm³ measuring cylinder
- three different insulating materials
- clamp, boss and stand
- stopwatch.

Plan an experiment to investigate the effectiveness of the three insulating materials.

You should

- explain briefly how you would carry out the investigation,
- state the key variables that you would control,
- draw a table, or tables, with column headings, to show how you would display your readings. You are not required to enter any readings in the table,
- explain how you would use your readings to reach a conclusion.

A diagram is not required but you may draw a diagram if it helps your explanation.

.....

.....

3 A student is investigating the cooling of water.

Some of the apparatus is shown in Fig. 5.1.

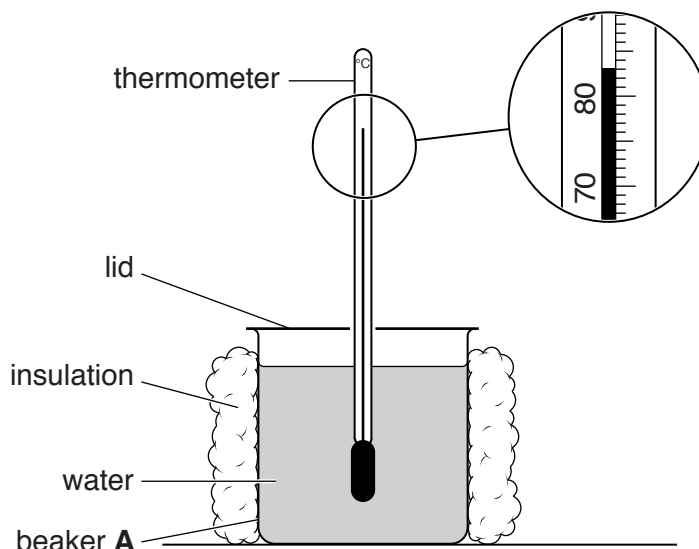

Fig. 5.1

(a) The student pours 200 cm^3 of hot water into a 250 cm^3 insulated beaker labelled **A**. He covers the top of the beaker with a lid.

The student takes a temperature reading every 30s as the water cools. The readings are shown in Table 5.1.

(i) Complete the column headings in the table. [1]

(ii) The starting temperature θ of the hot water in beaker **A** is shown on Fig. 5.1.

Record this temperature in the table at time $t = 0 \text{ s}$. [1]

Table 5.1

	beaker A insulation and lid	beaker B insulation, no lid	beaker C lid, no insulation
$t/$			
0		85	78
30	80	79	74
60	77	74	71
90	75	70	68
120	73	67	66
150	71	64	64

(b) The student repeats the procedure using a 250 cm³ beaker labelled **B**. This beaker is insulated but has no lid.

He repeats the procedure again using a 250 cm³ beaker labelled **C**. This beaker has a lid but no insulation.

All the readings are shown in Table 5.1.

(i) Tick the statement that best describes the results of the investigation.

Removing the lid speeds up the rate of cooling significantly more than removing the insulation.

Removing the insulation speeds up the rate of cooling significantly more than removing the lid.

There is no significant difference between removing the lid and removing the insulation.

[1]

(ii) Justify your answer by reference to the readings.

.....
.....
.....[1]

(c) State two of the conditions that should be kept the same in this experiment in order for the comparison to be fair.

1.
.....
2.
.....[2]

(d) Suggest a suitable material for the lid. Give a reason for your choice of material.

material
reason
.....[2]

(e) Describe briefly how a measuring cylinder is read in order to obtain a reliable value for the volume of water. You may draw a diagram.

.....

.....

.....

.....[2]

[Total: 10]

4 The class is investigating the cooling of water.

(a) A student pours 100cm^3 of hot water into a beaker. He places a thermometer in the water. Fig. 2.1 shows the thermometer.

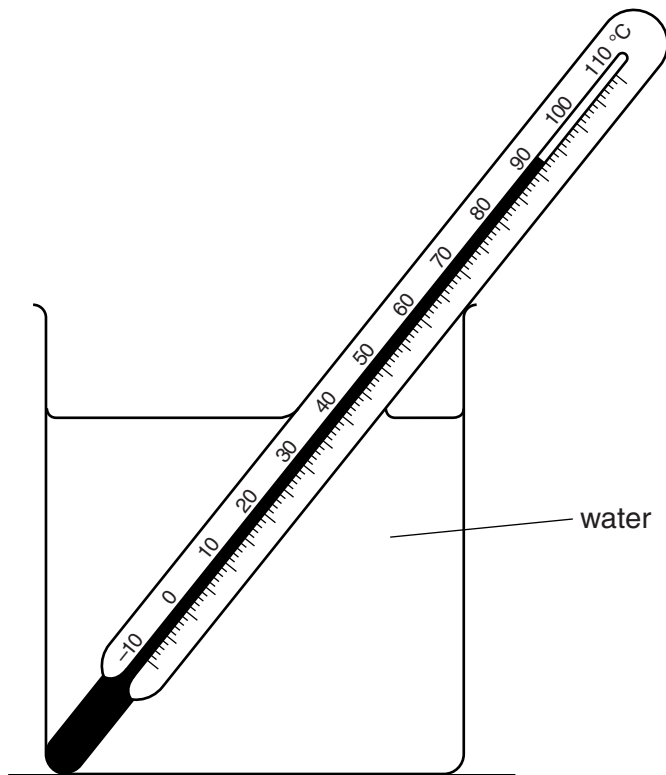

Fig. 2.1

(i) Record the temperature θ_H of the hot water as shown on the thermometer in Fig. 2.1.

$\theta_H = \dots\dots\dots[1]$

(ii) State one precaution that you would take to ensure that the temperature reading for the hot water is as reliable as possible.

.....
[1]

(b) The student adds 50cm^3 of cold water to the hot water. He records the temperature θ_1 .

$\theta_1 = \dots\dots\dots 71^\circ\text{C} \dots\dots\dots$

Calculate the decrease in temperature θ_A using the equation $\theta_A = (\theta_H - \theta_1)$.

$\theta_A = \dots\dots\dots[1]$

- (c) The student adds a further 100 cm^3 of cold water to the water in the beaker. He records the temperature θ_2 .

$$\theta_2 = \dots\dots\dots 57^\circ\text{C} \dots\dots\dots$$

Calculate the decrease in temperature θ_B using the equation $\theta_B = (\theta_1 - \theta_2)$.

$$\theta_B = \dots\dots\dots [1]$$

- (d) Suggest two factors, other than the volume and temperature of the cold water added, that affect the decrease in temperature of the hot water.

1.

.....

2.

.....

[2]

- (e) Describe briefly how a measuring cylinder is read to obtain an accurate value for the volume of water. You may draw a diagram.

.....

.....

.....

..... [2]

[Total: 8]

5 Two students are investigating thermal energy transfer.

They are using the apparatus shown in Fig. 5.1.

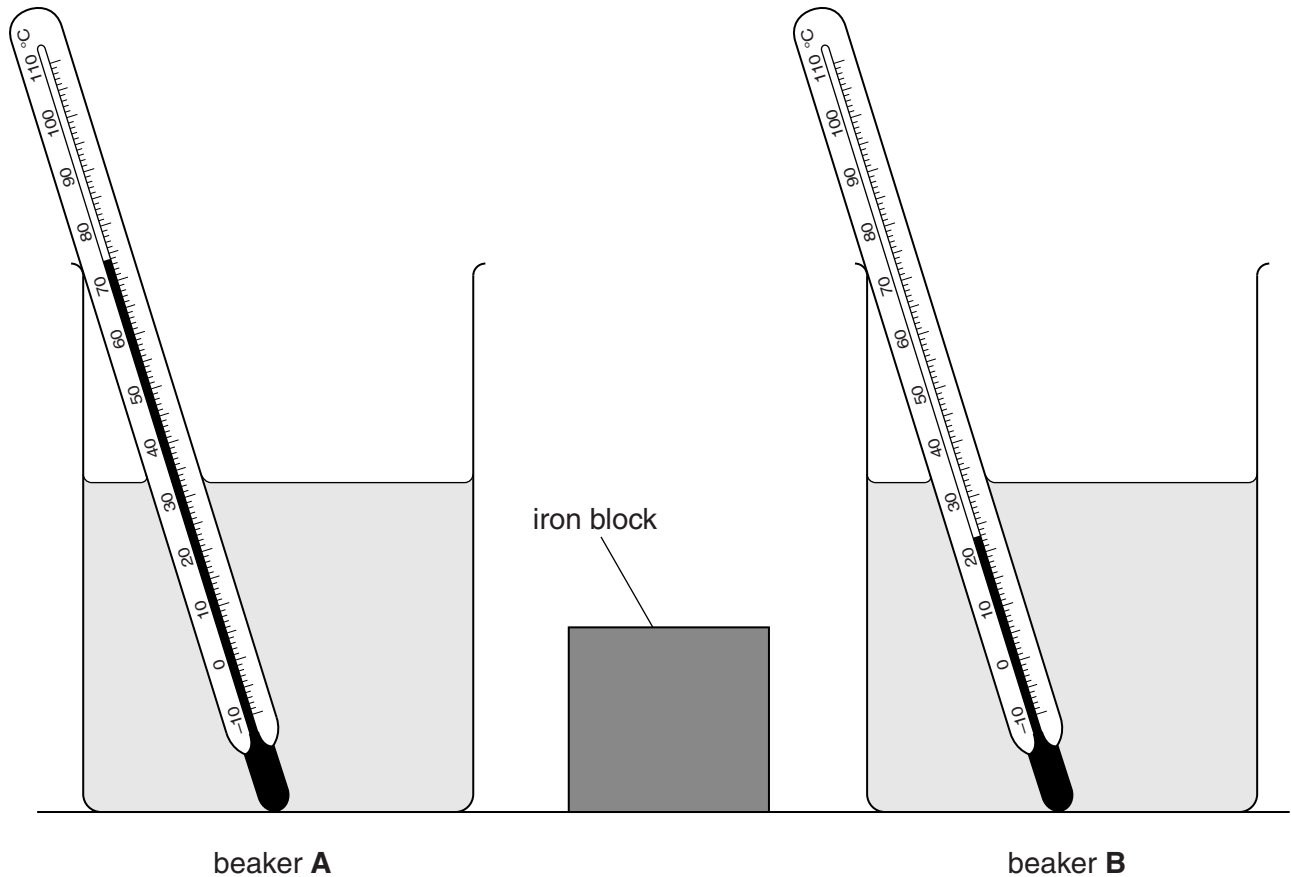

Fig. 5.1

Beaker **A** contains hot water and beaker **B** contains cold water at room temperature.

- (a) Record the temperature θ_H of the hot water and the temperature θ_C of the cold water as shown on the thermometers in Fig. 5.1.

$\theta_H = \dots\dots\dots$

$\theta_C = \dots\dots\dots$

[1]

- (b) Using metal tongs, one of the students places the iron block in the hot water in beaker **A** for 30 seconds.

He then removes the block and places it in the cold water in beaker **B**.

The other student then measures the temperature of the water in beaker **B** and finds that it has risen to 35°C. Their teacher suggests that this value is lower than expected.

- (i) The students suggest that, immediately before the iron block was put into the cold water, the temperature of the iron block was not the same as θ_H .

Suggest one reason for this and a possible improvement to the experiment which could make the temperature of the block nearer to θ_H .

reason

.....

.....

improvement

.....

.....

[2]

- (ii) The students also think that, when the block cooled in the water, not all of the thermal energy lost by the block raised the temperature of the water.

Suggest one reason for this and a possible improvement to the experiment which would reduce thermal losses.

reason

.....

.....

improvement

.....

.....

[2]

[Total: 5]

6 The class is investigating the cooling of a thermometer bulb.

Figs. 2.1 and 2.2 show the apparatus.

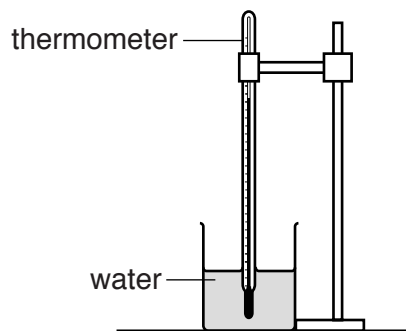

Fig. 2.1

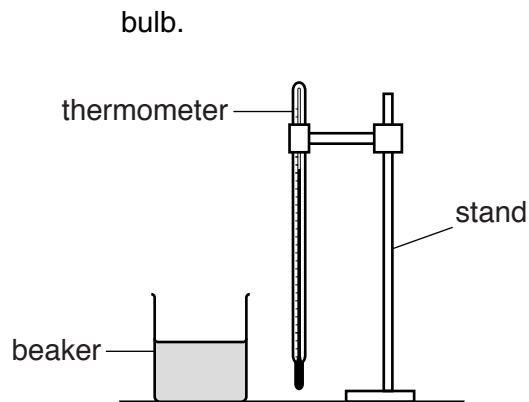

Fig. 2.2

(a) In the space in Table 2.1, record the temperature θ_1 of the hot water as shown on the thermometer in Fig. 2.3.

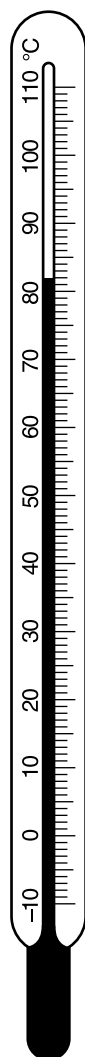

Fig. 2.3

- (b) A student removes the thermometer from the beaker of hot water, as shown in Fig. 2.2. She immediately starts a stopclock, and records the temperature θ_1 every 10s for 1 minute. The temperature readings are shown in Table 2.1.

Table 2.1

$t/$	$\theta_1/$	$\theta_2/$
0		33
	72	30
	65	28
	59	27
	53	26
	48	26
	43	25

She then adds 100 cm³ of cold water to the water in the beaker and repeats the procedure. She records the temperature readings in the θ_2 column of the table.

(i) Complete the column headings in the table.

(ii) Record the time readings in the table.

[2]

- (c) (i) Using the readings in the θ_1 column of the table, calculate the decrease in temperature $\Delta\theta_1$ in 60s.

$$\Delta\theta_1 = \dots\dots\dots$$

- (ii) Using the readings in the θ_2 column of the table, calculate the decrease in temperature $\Delta\theta_2$ in 60s.

$$\Delta\theta_2 = \dots\dots\dots$$

(iii) State the reason why $\Delta\theta_2$ is less than $\Delta\theta_1$.

.....

[2]

- (d) State a precaution that you would take when reading the thermometer scale in order to obtain reliable readings.

.....[1]

- (e) Suggest **one** reason why other students, carrying out this experiment with care, might obtain values of $\Delta\theta_1$ and $\Delta\theta_2$ different from the values in part (c).

.....

.....[1]

[Total: 7]