

# Light

## Question Paper 3

<b>Level</b>	IGCSE
<b>Subject</b>	Physics
<b>Exam Board</b>	CIE
<b>Topic</b>	Properties of Waves. Including Light and Sound
<b>Sub-Topic</b>	Light
<b>Paper Type</b>	Alternative to Practical
<b>Booklet</b>	Question Paper 3

**Time Allowed:** 54 minutes

**Score:** /45

**Percentage:** /100

- 1 A student is investigating the refraction of light in a transparent block. Her ray-trace will be used to determine a quantity known as the refractive index of the material of the block.

Fig. 5.1 shows her ray-trace sheet.

ray-trace sheet

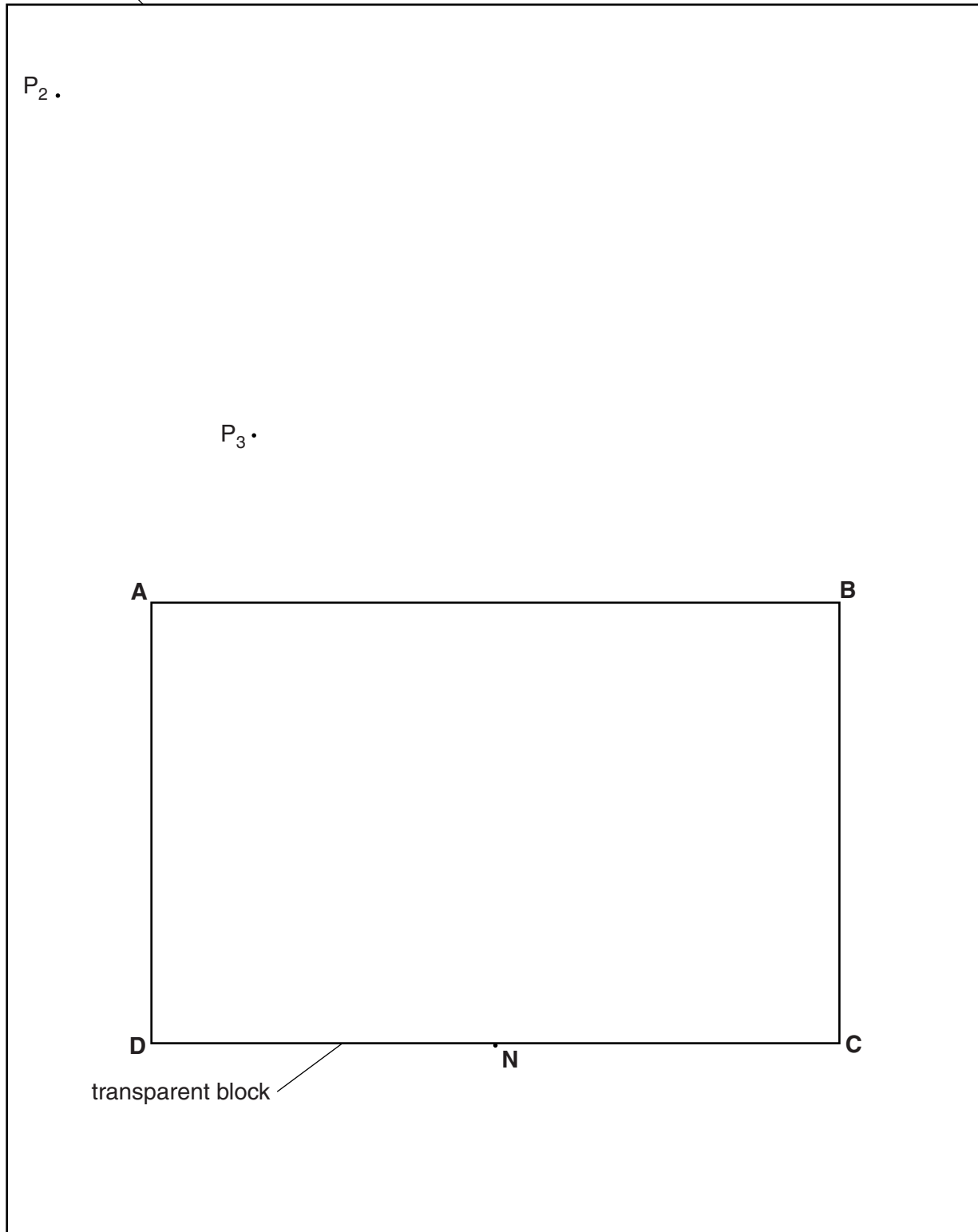

Fig. 5.1

The student draws the outline **ABCD** of the transparent block.

- (a) Draw a normal to the line **DC** through point **N**. Extend the normal beyond line **AB**.

Label the upper end of the normal with the letter **L**. Label the point at which **NL** crosses **AB** with the letter **E**. [1]

- (b) The student places a pin  $P_1$  against the block at point **N** and views the image of  $P_1$  through the side **AB** of the block.

She places two pins  $P_2$  and  $P_3$ , as shown in Fig. 5.1, so that pins  $P_2$  and  $P_3$ , and the image of  $P_1$ , all appear exactly one behind the other.

- (i) Draw a line joining the positions of  $P_2$  and  $P_3$ . Extend this line until it crosses **NL**. Label the point at which the line crosses **NL** with the letter **F**. [1]

- (ii) Measure the length  $a$  of line **EN**.

$a = \dots\dots\dots$

- (iii) Measure the length  $b$  of line **EF**.

$b = \dots\dots\dots$

[2]

- (c) Calculate a value  $n$  for the refractive index of the block, using your values from (b)(ii) and (b)(iii) and the equation  $n = \frac{a}{b}$ .

$n = \dots\dots\dots$ [1]

- (d) Suggest a practical precaution that you would take to ensure a reliable result in this type of experiment.

.....

.....[1]

- (e) The student obtains a second value for the refractive index  $n$  by repeating the experiment with the block standing on edge, as shown in Fig. 5.2.

She views the image of  $P_1$  from the direction indicated by the arrow. The block is 1.5 cm thick.

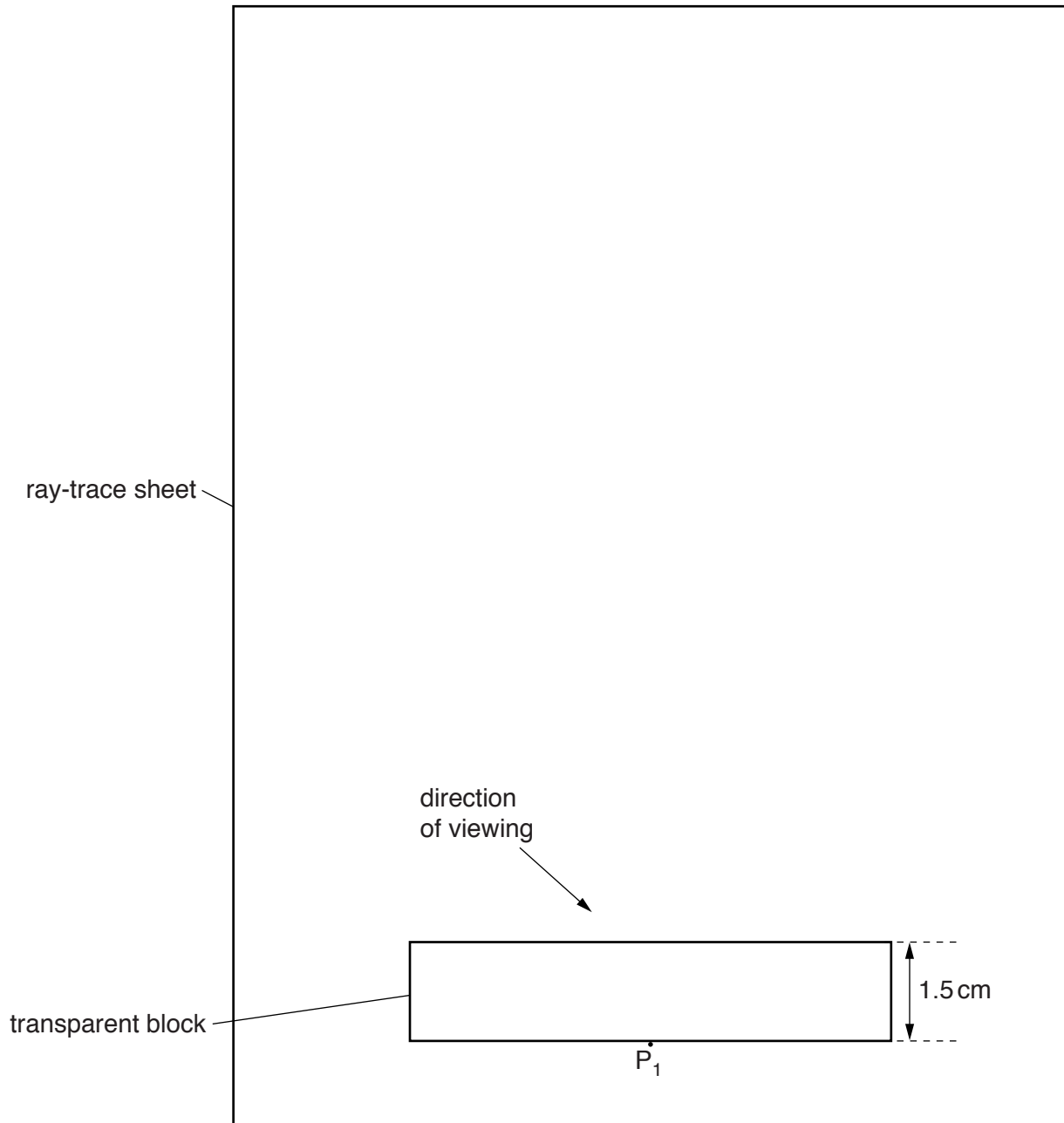

Fig. 5.2

State and explain whether this value for the refractive index is likely to be more or less reliable than the value  $n$  obtained for the refractive index in part (c).

statement .....

explanation .....

.....

.....

[2]

[Total: 8]

2 The IGCSE class is investigating reflection using a plane mirror.

Fig. 5.1 shows a student's ray-trace sheet with a line **MR** drawn on it. In the experiment the reflecting face of a mirror is placed vertically on the line **MR**. The additional dashed line shows a second mirror position.

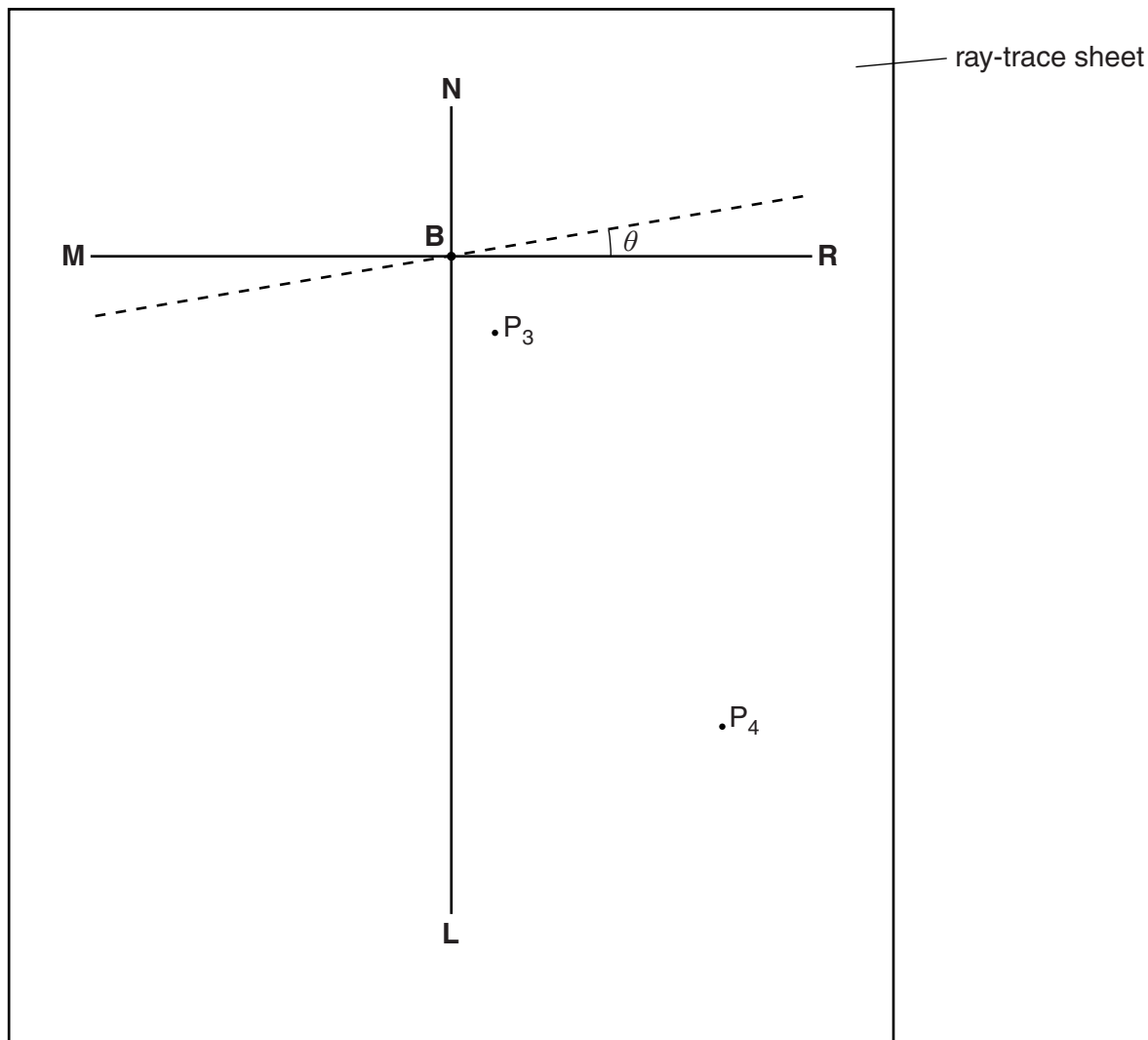

Fig. 5.1

- (a) **NL** is a normal to line **MR**. Draw a line 8.0cm long from **B** at an angle of incidence  $i = 30^\circ$  to the normal, below **MR** and to the left of the normal. Label the end of this line **A**. [1]
- (b) The student places two pins,  $P_1$  and  $P_2$ , on line **AB** a suitable distance apart for this ray tracing experiment. He views the images of pins  $P_1$  and  $P_2$  in the mirror and places two pins  $P_3$  and  $P_4$  so that pins  $P_3$  and  $P_4$ , and the images of  $P_2$  and  $P_1$ , all appear exactly one behind the other. The positions of  $P_3$  and  $P_4$  are shown in Fig. 5.1.
- (i) Draw the line joining the positions of  $P_3$  and  $P_4$ . Extend the line until it meets **NL**.
- (ii) Measure the angle  $\alpha_0$  between **NL** and the line joining the positions of  $P_3$  and  $P_4$ . At this stage the angle  $\theta$  between the mirror and line **MR** is  $0^\circ$ .

$\alpha_0 = \dots\dots\dots$

[2]

- (c) The student draws lines at angles  $\theta = 10^\circ, 20^\circ, 30^\circ,$  and  $40^\circ$  to **MR**. The first line, at  $10^\circ$  to **MR**, is shown in Fig. 5.1. He repeats the procedure described in part (b), placing the mirror on each of the new lines in turn. The readings are shown in Table 5.1.

**Table 5.1**

$\theta/^\circ$	$\alpha/^\circ$
10	51
20	69
30	90
40	111
50	130

Plot a graph of  $\alpha/^\circ$  ( $y$ -axis) against  $\theta/^\circ$  ( $x$ -axis).

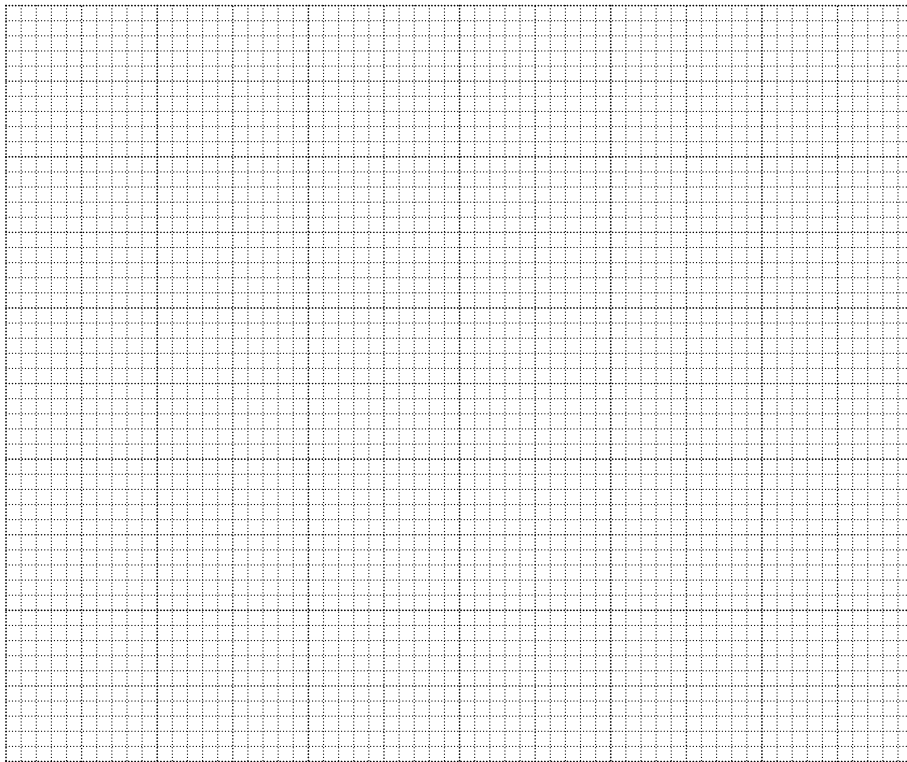

[5]

- (d) Determine the gradient  $G$  of the graph. Show clearly on the graph how you obtained the necessary information.

$G = \dots\dots\dots$  [2]

- (e) In this experiment, when the mirror is moved through an angle  $\theta$ , the reflected ray moves through an angle  $(\alpha - \alpha_0)$ .

Table 5.2

$\theta/^\circ$	$\alpha/^\circ$	$(\alpha - \alpha_0)/^\circ$
10	51	
20	69	
30	90	
40	111	
50	130	

(i) Complete Table 5.2.

(ii) Suggest the relationship between  $(\alpha - \alpha_0)$  and  $\theta$ . You may express the relationship in words or as an equation.

.....  
.....  
[1]

(f) State **one** precaution, to improve accuracy, which you would take in this experiment.

.....  
.....[1]

[Total: 12]



3 An IGCSE student is determining the focal length of a lens.

Fig. 4.1 shows the apparatus.

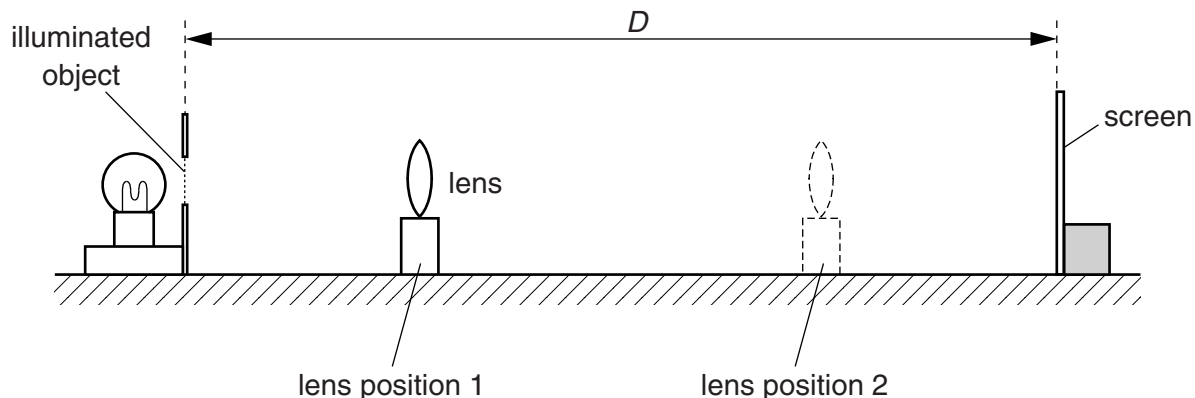

Fig. 4.1

- (a) The student places the screen at a distance  $D = 80.0\text{cm}$  from the illuminated object. He places the lens close to the illuminated object. He moves the lens until a sharply-focused image of the object is seen on the screen (lens position 1).

He measures the distance  $x$  from the illuminated object to the centre of the lens.

$$x = \dots\dots\dots 19.5\text{cm}$$

He does not move the object or the screen, but moves the lens towards the screen until another sharply-focused image of the object is seen on the screen (lens position 2). He measures the distance  $y$  from the illuminated object to the centre of the lens.

$$y = \dots\dots\dots 60.4\text{cm}$$

- (i) On Fig. 4.1, carefully mark and label the distances  $x$  and  $y$ . [1]

- (ii) Calculate  $d$  using the equation  $d = (y - x)$ .

$$d = \dots\dots\dots$$

- (iii) Calculate  $d^2$ .

$$d^2 = \dots\dots\dots$$

(iv) Calculate the focal length  $f$  of the lens, using the equation  $f = \frac{D^2 - d^2}{4D}$ .

$f =$  ..... [2]

(b) State two precautions that you would take in this experiment to obtain reliable results.

- 1. ....
- .....
- 2. ....
- ..... [2]

(c) In the experiment, the student produces two images on the screen. They are both sharply focused.

(i) Suggest two differences between the two images.

- 1. ....
- 2. ....

(ii) Suggest one similarity between the two images.

..... [3]

.....

(d) Suggest a variable that could be changed when repeating this experiment to check the accuracy of the value obtained for the focal length  $f$ .

..... [1]

[Total: 9]

4 An IGCSE student is investigating shadows.

The apparatus she is using is shown in Fig. 5.1.

The object and the screen are square, with dimensions as shown in Fig. 5.1.

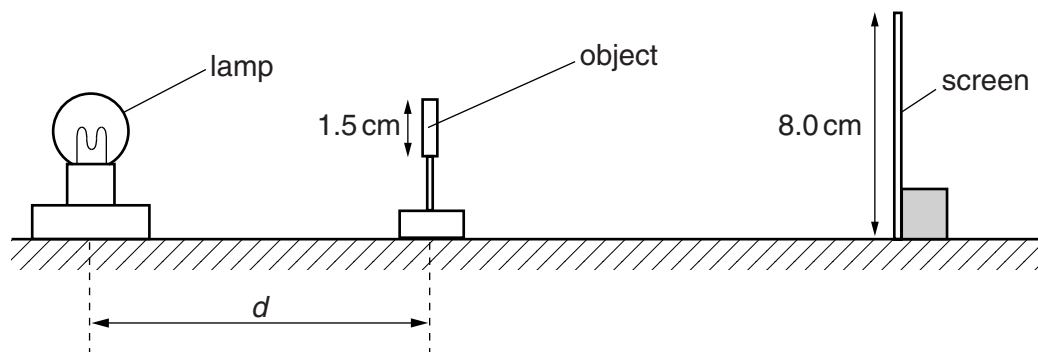

Fig. 5.1

She places the object at a distance  $d$  from the centre of the lamp so that it produces a shadow on the screen.

For various values of  $d$ , she measures the width  $w$  and height  $h$  of the shadow and records them in Table 5.1.

For each distance  $d$ , she calculates a value  $s$ , the average side length of the shadow, using her readings for  $w$  and  $h$  and the equation  $s = \frac{w + h}{2}$ .

(a) Fig. 5.2 shows the shadow produced on the screen when  $d = 35$  cm. The shadow and screen are shown full size.

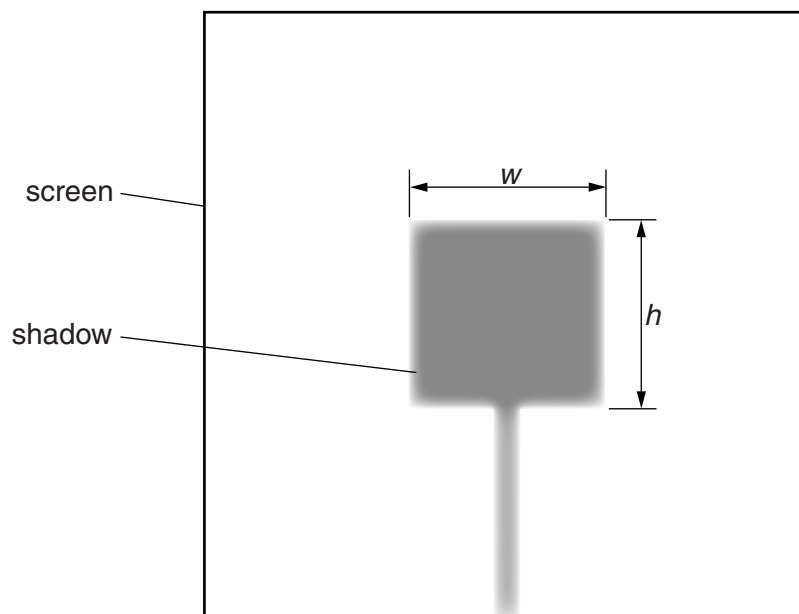

Fig. 5.2

- (i) Measure, and record in Table 5.1, the width  $w$  and the height  $h$  of the shadow.

**Table 5.1**

$d/cm$	$w/cm$	$h/cm$	$s/cm$
55	1.7	1.7	1.7
45	2.0	2.0	2.0
35			
25	3.8	3.9	3.9
20	4.4	4.6	4.5
15	5.8	6.2	6.0

[2]

- (ii) Calculate, and record in the table, the value of  $s$  when  $d = 35$  cm.
- (iii) The object is square in shape. State a practical reason why it is useful to calculate  $s$  rather than just rely on  $w$  or  $h$  to show the size of the shadow.

.....  
 .....[1]

- (b) Plot a graph of  $s/cm$  ( $y$ -axis) against  $d/cm$  ( $x$ -axis).

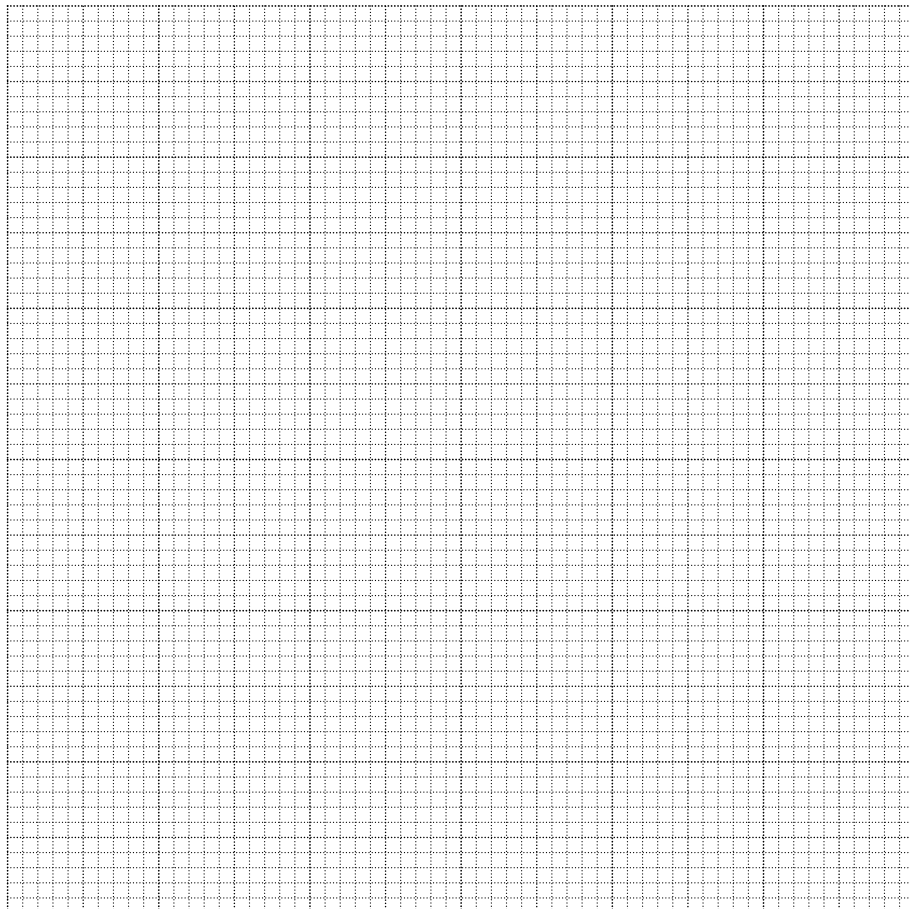

[5]

- (c) A value of  $d = 20\text{cm}$  has been inserted between  $d = 25\text{cm}$  and  $d = 15\text{cm}$ . This does not follow the pattern of the gaps of  $10\text{cm}$  between the other distances.

Explain why it is useful to have this value when drawing the line on the graph.

.....  
.....[1]

- (d) A student suggests that the distance between the lamp and the object in this experiment should be no less than  $15\text{cm}$ .

From your observations of the readings and the apparatus being used, give a reason why this is a sensible suggestion.

.....  
.....[1]

[Total: 10]

- 5 The IGCSE class is investigating the reflection of light by a plane mirror. Fig. 1.1 shows a student's ray-trace sheet.

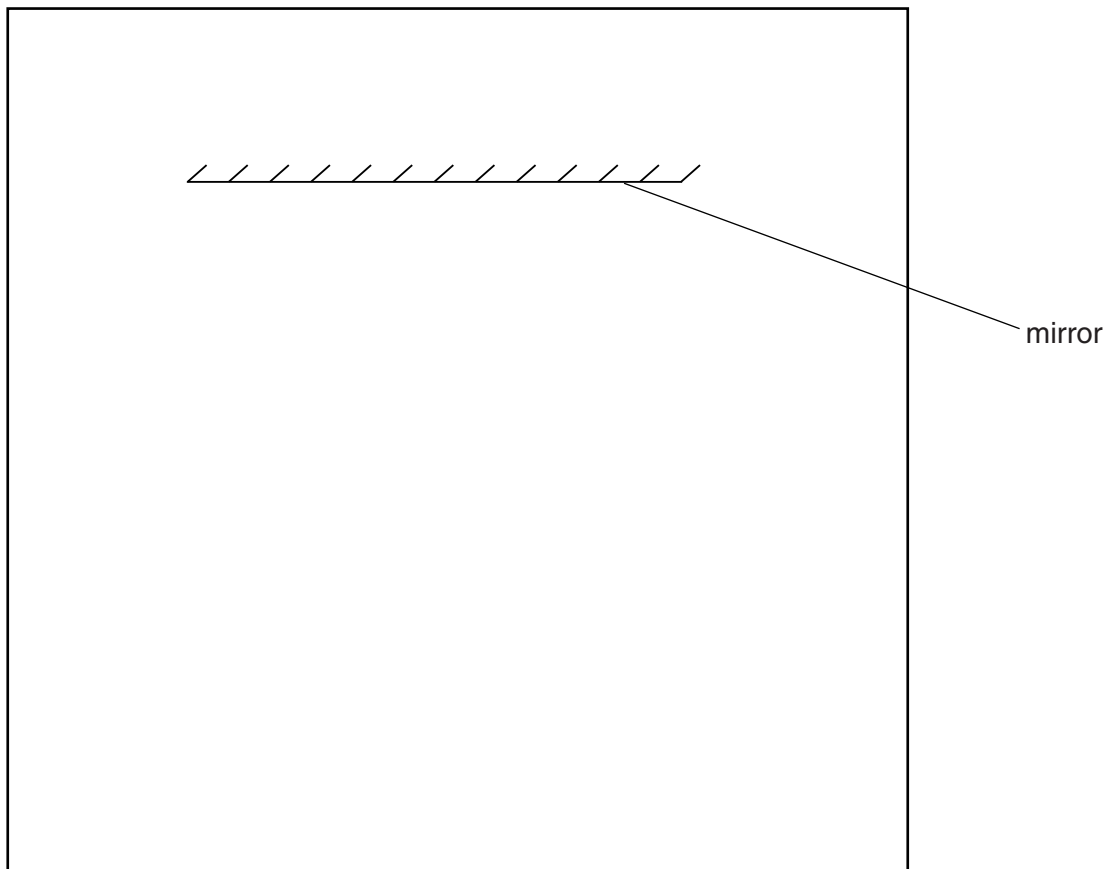

Fig. 1.1

- (a) On Fig. 1.1, draw a normal to the centre of the mirror. [1]
- (b) On Fig. 1.1, draw an incident ray at  $30^\circ$  to the normal and to the left of the normal. [1]
- (c) Fig. 1.2 shows a diagram of a ray box.

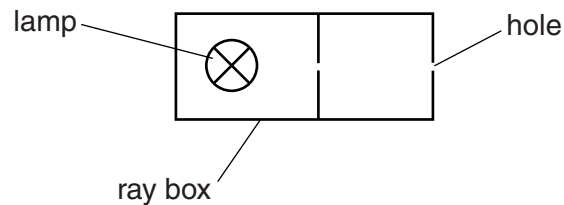

Fig. 1.2

- On Fig. 1.1, draw the ray box in a suitable position to produce the incident ray that you have drawn. [1]
- (d) On Fig. 1.1, draw a reflected ray in the position you would expect it to be using the incident ray that you have drawn. [1]

(e) State two precautions that you could take in this experiment to obtain reliable results.

1. ....

.....

2. ....

.....

[2]

[Total: 6]