

# Electrical Circuits

## Question Paper 1

|                   |                           |
|-------------------|---------------------------|
| <b>Level</b>      | IGCSE                     |
| <b>Subject</b>    | Physics                   |
| <b>Exam Board</b> | CIE                       |
| <b>Topic</b>      | Electricity and Magnetism |
| <b>Sub-Topic</b>  | Electrical Circuits       |
| <b>Paper Type</b> | Alternative to Practical  |
| <b>Booklet</b>    | Question Paper 1          |

**Time Allowed:** 63 minutes

**Score:** /52

**Percentage:** /100

- 1 A student is investigating how the resistance of a wire depends on the length of the wire. The student aims to plot a graph.

The following apparatus is available to the student:

ammeter  
voltmeter  
power supply  
variable resistor  
switch  
connecting leads  
resistance wires of different lengths  
metre rule.

Plan an experiment to investigate how the resistance of a wire depends on the length of the wire.

You should

- draw a diagram of the circuit you could use to determine the resistance of each wire
- explain briefly how you would carry out the investigation
- suggest suitable lengths of wire
- state the key variables that you would control
- draw a table, or tables, with column headings to show how you would display your readings. You are not required to enter any readings in the table.



- 2 The class is investigating a circuit containing two lamps in series.  
They are using the circuit shown in Fig. 4.1.

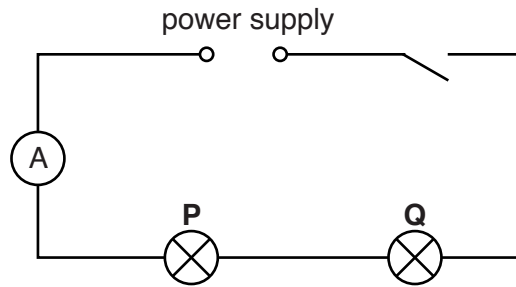

Fig. 4.1

- (a) On Fig. 4.1, use the standard symbol to show a voltmeter connected to measure the potential difference (p.d.) across lamp **P**. [1]
- (b) Record the current  $I$  in the circuit, as shown on the ammeter in Fig. 4.2.

$I = \dots\dots\dots$  [2]

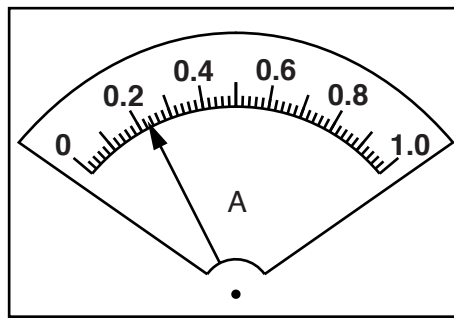

Fig. 4.2

(c) Fig. 4.3 shows the readings on voltmeters connected to measure the potential difference across each lamp.

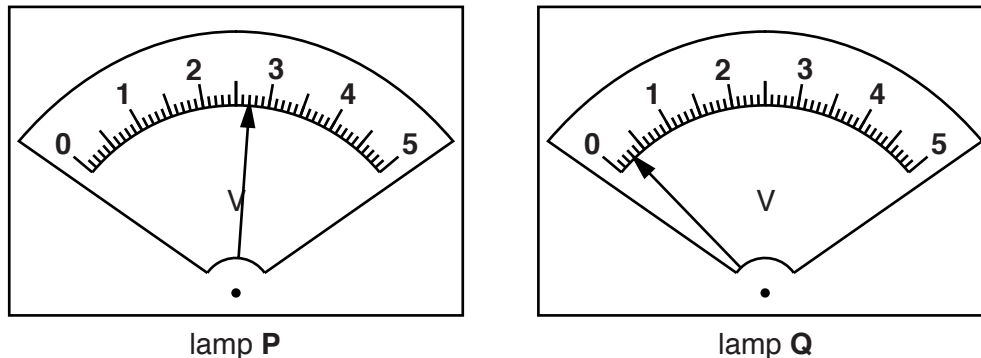

Fig. 4.3

In Table 4.1, record the potential difference  $V_P$  across lamp **P** and the potential difference  $V_Q$  across lamp **Q**.

Table 4.1

| lamp     | potential difference / V | observation of brightness |
|----------|--------------------------|---------------------------|
| <b>P</b> | $V_P = \dots\dots\dots$  | very bright               |
| <b>Q</b> | $V_Q = \dots\dots\dots$  | not glowing               |

[1]

(d) Table 4.1 also shows the brightness of each lamp.

(i) A student thinks that, as lamp **Q** is not glowing, its filament must have broken.

State one piece of evidence from the results in (b) and (c) that shows this cannot be the case.

.....  
 .....[1]

(ii) The working potential difference for each lamp to be at its full brightness is 2.5V.

Suggest how the results for  $V_P$  and  $V_Q$  might help to explain the observations of the brightness of the lamps.

.....  
 .....  
 .....  
 .....[2]

(e) Calculate the total resistance  $R$  of the lamps in the circuit, using the equation

$$R = \frac{(V_P + V_Q)}{I} .$$

$$R = \dots\dots\dots[2]$$

(f) A student measures the potential difference  $V_S$  across the power supply.

$$V_S = \dots\dots\dots 3.1V \dots\dots\dots$$

He suggests that  $V_S$  should be equal to  $V_P + V_Q$  .

State whether the measurements support this suggestion. Justify your statement by reference to the results.

statement .....

justification .....

.....  
[2]

[Total: 11]

3 A student is investigating the effect of the length of resistance wire in a circuit on the potential difference across a lamp.

(a) Fig. 3.1 shows the circuit without a voltmeter.

Complete the circuit diagram to show a voltmeter connected in the circuit to measure the potential difference across the lamp. [2]

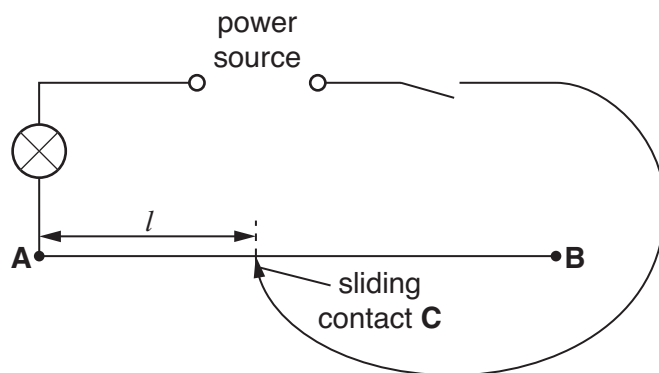

Fig. 3.1

(b) The student switches on and places the sliding contact C on the resistance wire at a distance  $l = 0.200\text{ m}$  from end A.

The voltmeter reading is shown in Fig. 3.2.

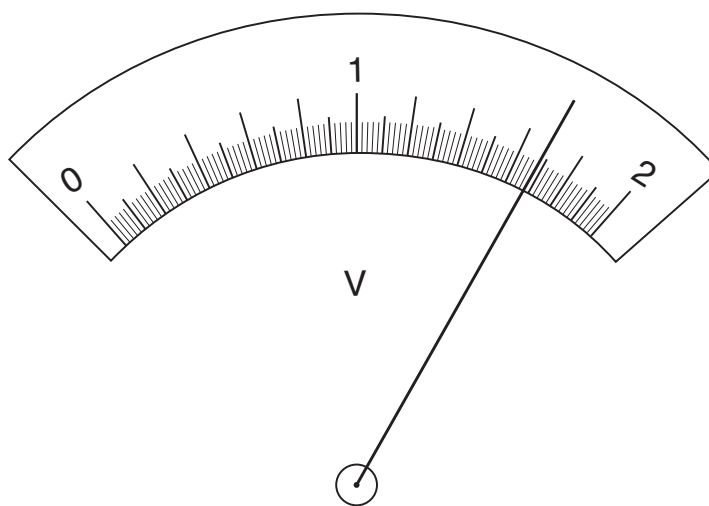

Fig. 3.2

Record the voltmeter reading in Table 3.1.

| $l/m$ | $V/V$ |
|-------|-------|
| 0.200 |       |
| 0.400 | 1.43  |
| 0.600 | 1.25  |
| 0.800 | 1.11  |
| 1.000 | 1.00  |

[1]

- (c) The student repeats the procedure using a range of values of  $l$ . Table 3.1 shows the readings. Use the results for the potential difference across the lamp to predict how increasing the length  $l$  affects the brightness of the lamp.

..... [1]

- (d) The student suggests that the potential difference  $V$  across the lamp is directly proportional to the length  $l$  of resistance wire in the circuit.

State whether you agree with this suggestion. Justify your answer by reference to the results.

statement .....

justification .....

.....  
 .....

[2]

- (e) The student repeats the experiment.

Suggest a practical reason why the repeat readings may be slightly different from those recorded in Table 3.1.

.....  
 ..... [1]

- (f) State one safety precaution that you would take when carrying out experiments like this with resistance wires.

..... [1]

[Total: 8]



4 The class is investigating the resistance of lamp filaments in series and parallel circuits.

Fig. 3.1 shows the first circuit used.

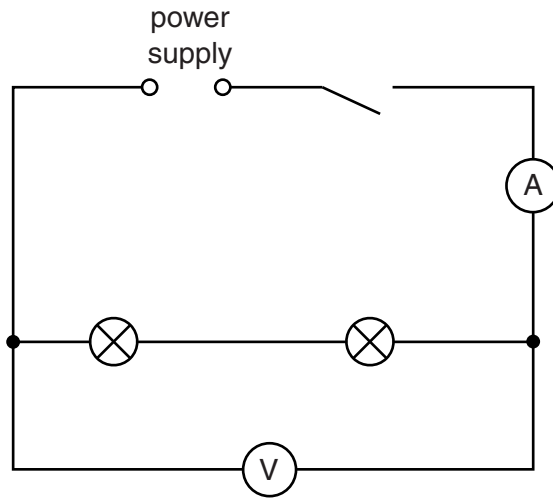

Fig. 3.1

(a) (i) Write down the readings shown on the meters in Figs. 3.2 and 3.3.

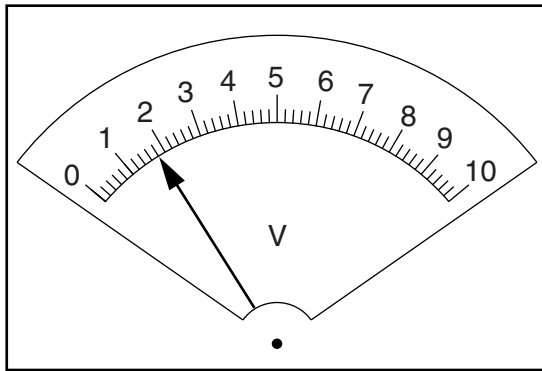

Fig. 3.2

$V_S = \dots\dots\dots$

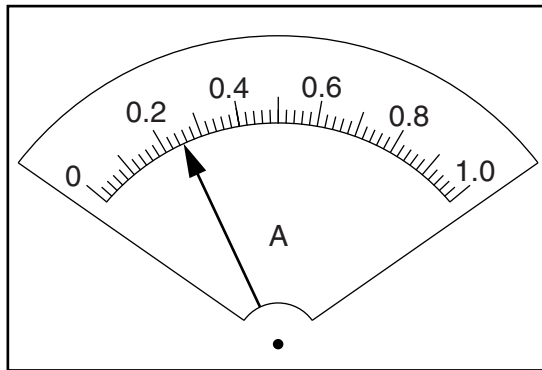

Fig. 3.3

$I_S = \dots\dots\dots$

[2]

(ii) Calculate the resistance  $R_S$  of the lamp filaments using the equation  $R_S = \frac{V_S}{I_S}$ .

$R_S = \dots\dots\dots$ [1]

- (b) The student rearranges the circuit so that
- the lamps are in parallel
  - the ammeter will measure the total current in the circuit
  - the voltmeter will measure the potential difference across the lamps.

(i) Draw a diagram of this circuit using standard circuit symbols.

[2]

- (ii) The student measures the potential difference  $V_P$  across the lamps and the current  $I_P$  in the circuit.

$$V_P = \dots\dots\dots 2.0V \dots\dots\dots$$

$$I_P = \dots\dots\dots 0.60A \dots\dots\dots$$

Calculate the resistance  $R_P$  of the lamp filaments using the equation  $R_P = \frac{V_P}{I_P}$ .

$$R_P = \dots\dots\dots$$

- (iii) Calculate the ratio  $\frac{R_S}{R_P}$ .

$$\frac{R_S}{R_P} = \dots\dots\dots [1]$$

(c) A student wishes to investigate whether the ratio  $\frac{R_S}{R_P}$  for the two lamps is the same under all conditions.

(i) Suggest a variable that you could change in order to obtain further sets of readings.

.....

(ii) Explain briefly how you would change this variable.

.....

.....

[2]

[Total: 8]

5 The class is investigating the resistance of lamps.

Fig. 3.1 shows the first circuit used.

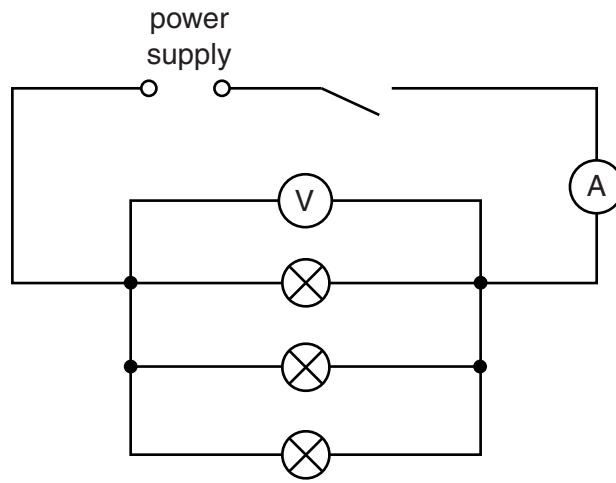

Fig. 3.1

(a) A student measures the potential difference  $V_P$  across the lamps and the current  $I_P$  in the circuit. The readings are shown in Figs. 3.2 and 3.3.

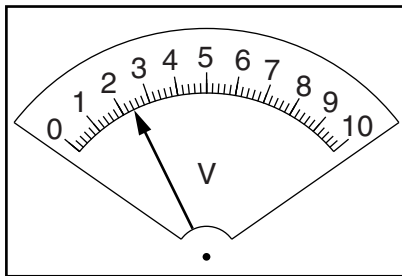

Fig. 3.2

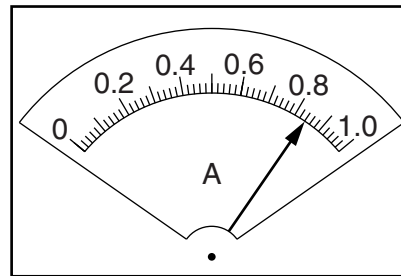

Fig. 3.3

(i) Write down the readings shown on the meters.

$V_P =$  .....

$I_P =$  .....

[2]

(ii) Calculate the resistance  $R_P$  of the lamp filaments using the equation  $R_P = \frac{V_P}{I_P}$ .

$R_P =$  .....[1]

- (b) The student rearranges the circuit so that
- the lamps are in series
  - the ammeter will measure the total current in the circuit
  - the voltmeter will measure the potential difference across all three lamps.

In the space below, draw a diagram of this circuit using standard circuit symbols.

[2]

- (c) The student measures the potential difference  $V_S$  across the lamps and the current  $I_S$  in the circuit in (b).

$$V_S = \dots\dots\dots 2.5V \dots\dots\dots$$

$$I_S = \dots\dots\dots 0.22A \dots\dots\dots$$

Calculate the resistance  $R_S$  of the lamp filaments using the equation  $R_S = \frac{V_S}{I_S}$ .

$$R_S = \dots\dots\dots [1]$$

- (d) (i) A student wishes to vary the current in the first circuit, shown in Fig. 3.1, using a variable resistor.

In the space below, draw the standard circuit symbol for a variable resistor.

[1]

- (ii) On Fig. 3.1, label with X a suitable position in the first circuit for a variable resistor used to vary the current in all the lamps. [1]

[Total: 8]

- 6 Some students are investigating the link between the brightness of a filament lamp and its resistance.

The circuit is shown in Fig. 3.1.

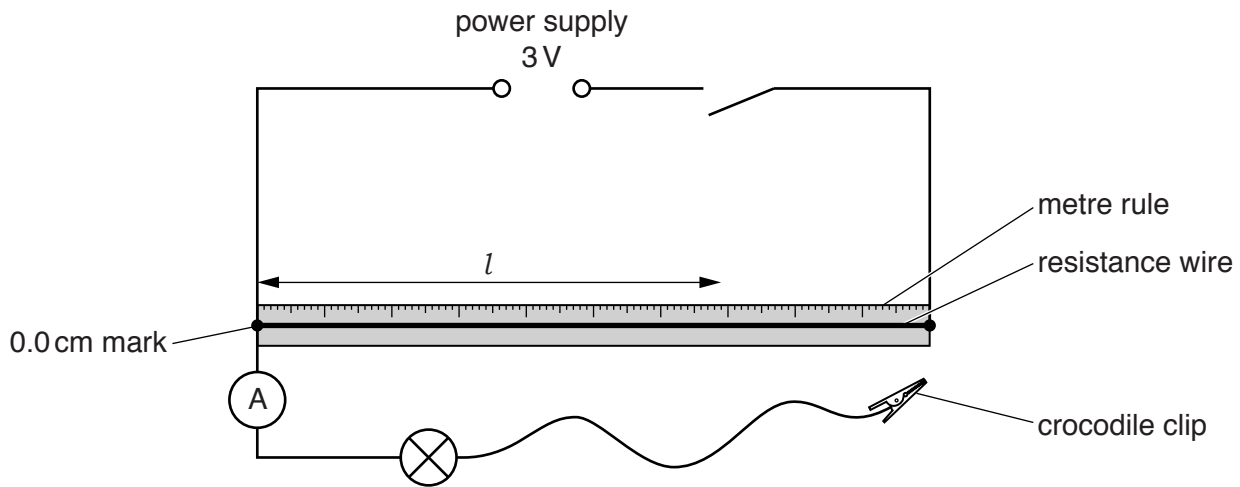

Fig. 3.1

- (a) On Fig. 3.1, use standard symbols to show a voltmeter connected to measure the potential difference across the lamp. [1]
- (b) The students attach the crocodile clip to various lengths  $l$  of the resistance wire and record, in Table 3.1, the potential difference  $V$  and the current  $I$  for the lamp. They also record observations of the lamp filament.

Table 3.1

| $l/\text{cm}$ | $V/\text{V}$ | $I/\text{A}$ | observation of lamp filament | $R/\Omega$ |
|---------------|--------------|--------------|------------------------------|------------|
| 100           | 2.5          | 0.26         | bright                       |            |
| 60            | 1.5          | 0.19         | dim                          |            |
| 20            | 0.5          | 0.11         | just glowing                 |            |

Voltmeters with the ranges shown in Fig. 3.2 are available.

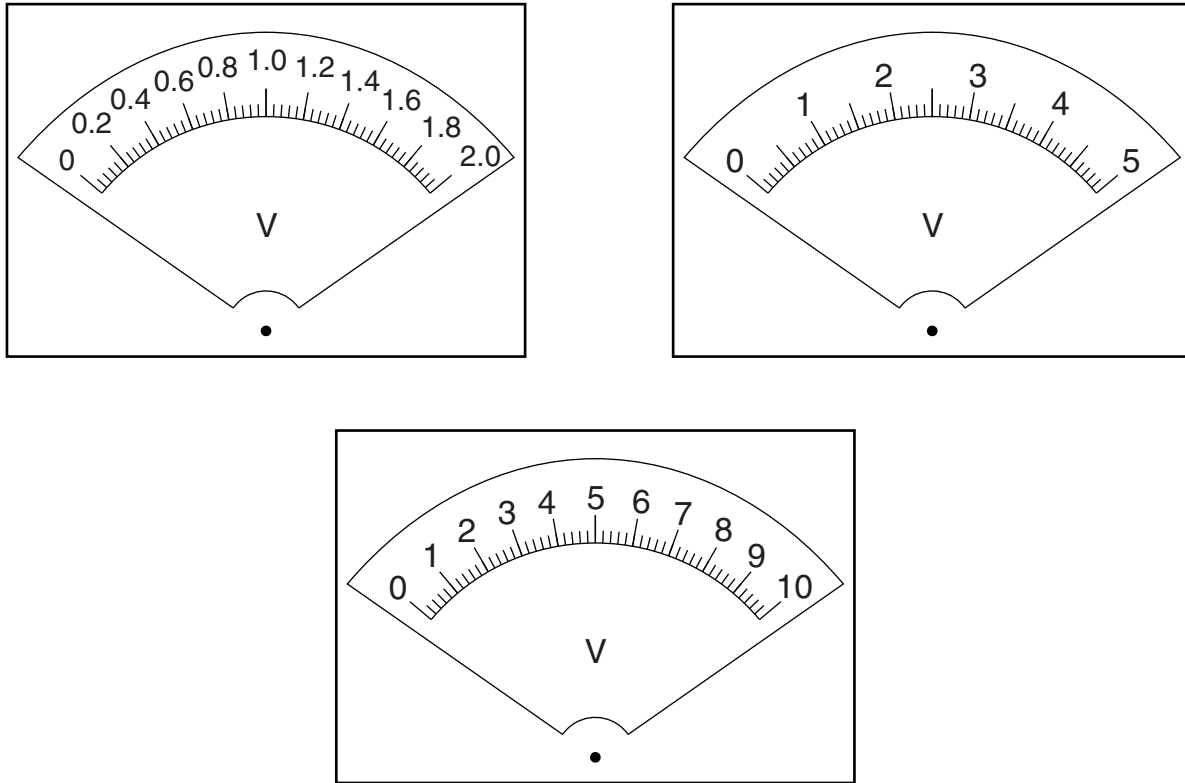

Fig. 3.2

- (i) On Fig. 3.2, circle the voltmeter which is most appropriate for this experiment.
- (ii) Draw an arrow on this voltmeter to show the reading when the crocodile clip is attached to a length  $l = 60$  cm of the resistance wire. [2]
- (c) Calculate, and record in the table, the resistance  $R$  of the lamp for each value of  $l$ , using the equation  $R = \frac{V}{I}$ . [2]
- (d) From the results and the observations of the lamp filament, state the link, if any, between the brightness of the lamp and its resistance. Explain clearly how the results support your statement.

statement .....

explanation .....

.....

.....

.....

- (e) A student wishes to see if another lamp shows the same link between brightness and resistance. However, his lamp only glows dimly when a potential difference of 3V is applied across it.

The student decides that a method using a resistance wire is not suitable.

Suggest an alternative circuit and apparatus which would allow him to vary the brightness of his lamp and measure the potential difference and current for his lamp. You may draw a circuit diagram.

.....  
.....  
.....  
.....[3]

[Total: 10]