

Electrical Circuits

Question Paper 5

Level	IGCSE
Subject	Physics
Exam Board	CIE
Topic	Electricity and Magnetism
Sub-Topic	Electrical Circuits
Paper Type	Alternative to Practical
Booklet	Question Paper 5

Time Allowed: 57 minutes

Score: /47

Percentage: /100

- 1 The IGCSE class is investigating current and potential difference using identical lamps in a circuit.

The circuit is shown in Fig. 3.1.

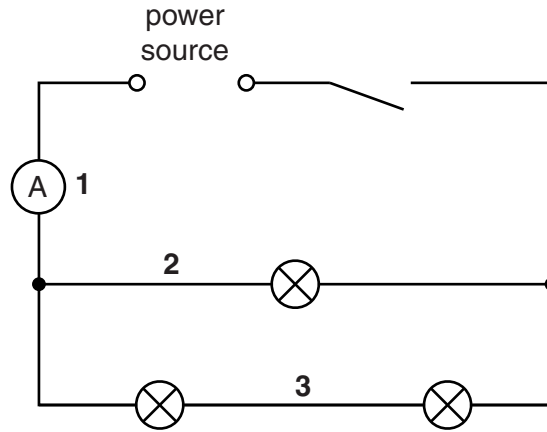

Fig. 3.1

- (a) On Fig. 3.1, draw the symbol for a voltmeter connected to measure the potential difference V across the combination of lamps. [1]
- (b) On Fig. 3.2, draw a pointer showing the voltmeter reading $V = 1.9V$.

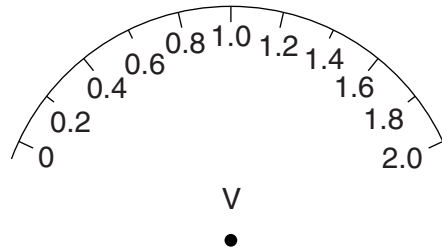

Fig. 3.2

[1]

- (c) (i) A student measures the current at positions 1, 2 and 3 in the circuit. Record the current at each position as shown on the ammeters in Fig. 3.3.

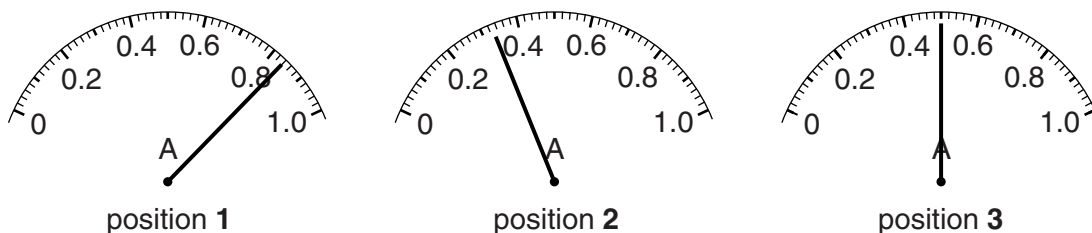

Fig. 3.3

$I_1 = \dots\dots\dots$

$I_2 = \dots\dots\dots$

$I_3 = \dots\dots\dots$

[1]

- (ii) Calculate the total current I_C in the combination of lamps using the equation $I_C = I_2 + I_3$.

$I_C =$

- (iii) Theory indicates that $I_1 = I_C$. Suggest why a student may find the two values to be different in this experiment.

.....
.....
..... [1]

- (d) The student decides to investigate the effect of changing the current I_1 , using a variable resistor (rheostat).

In the space below, copy the diagram shown in Fig. 3.1, but with the addition of a variable resistor connected at a suitable position for the investigation.

[2]

- (e) A student sets up the circuit as shown in Fig. 3.1. Neither of the two lamps in series glows. He suspects that one of the lamps is faulty.

Suggest how the apparatus may be used to find out which lamp is faulty.

.....
..... [1]

[Total: 7]

2 The IGCSE class is investigating the resistance of a lamp.

The apparatus has been set out as shown in Fig. 3.1.

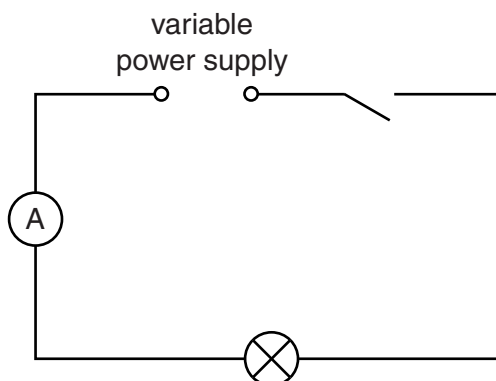

Fig. 3.1

- (a) On Fig. 3.1, draw the symbol for a voltmeter correctly connected to measure the potential difference across the lamp. [2]
- (b) Table 3.1 shows the values of potential difference V and current I obtained during the experiment, and observations regarding the lamp.

Table 3.1

$V/$	$I/$	$R/$	observation
1.5	0.15		lamp is just glowing
3.2	0.23		lamp is lit but is dim
4.7	0.26		lamp is brighter
6.5	0.31		lamp is very bright

[3]

- (i) Complete the column headings in Table 3.1.
- (ii) Calculate, and record in the table, the resistance R of the lamp at each potential difference V using the equation $R = \frac{V}{I}$.

- (c) A student suggests that the resistance of a lamp stays the same whatever its temperature.

State whether the results support this idea. Justify your answer, using the results and the observations obtained during the experiment.

statement

.....

justification

.....

.....

.....

[3]

[Total: 8]

3 The IGCSE class is measuring the currents in lamps in different circuits.

The first circuit is shown in Fig. 3.1.

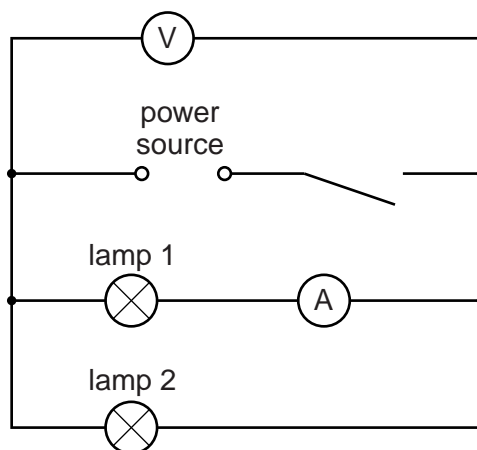

Fig. 3.1

- (a) A student records the potential difference V across the lamps and the current I in lamp 1. She rearranges the circuit so that the ammeter is connected in series with lamp 2 and again records the potential difference V across the lamps and the current I in lamp 2.

The readings are shown in Table 3.1.

Table 3.1

	$V/$	$I/$	$R/$
lamp 1	1.9	0.35	
lamp 2	1.9	0.32	

- (i) Calculate the resistance R of each lamp, using the equation $R = \frac{V}{I}$, and enter the results in the table.
- (ii) Add together the two values of R to calculate R_S , the sum of the resistances of the two lamps.
- $R_S = \dots\dots\dots$
- (iii) Complete the column headings in the table.

- (b) The student rearranges the circuit so that the lamps and the ammeter are in series. She does not change the position of the voltmeter.

She records the readings on the voltmeter and the ammeter.

voltmeter reading.....1.9V

ammeter reading.....0.23A

- (i) Draw a circuit diagram of the rearranged circuit using conventional symbols.

- (ii) Use the voltmeter and ammeter readings to calculate R_T , the combined resistance of the two lamps in series.

$$R_T = \dots\dots\dots[3]$$

- (c) A student suggests that the values of R_S and R_T should be equal. State whether the results support this suggestion and justify your statement by reference to the calculated values.

statement

justification

.....[2]

- (d) State, without reference to the values of resistance that you have calculated, one piece of evidence that the student can observe during the experiment that shows that the temperature of the lamp filaments changes.

.....

.....[1]

4 The IGCSE class is investigating the resistance of a wire.

Fig. 3.1 shows the circuit.

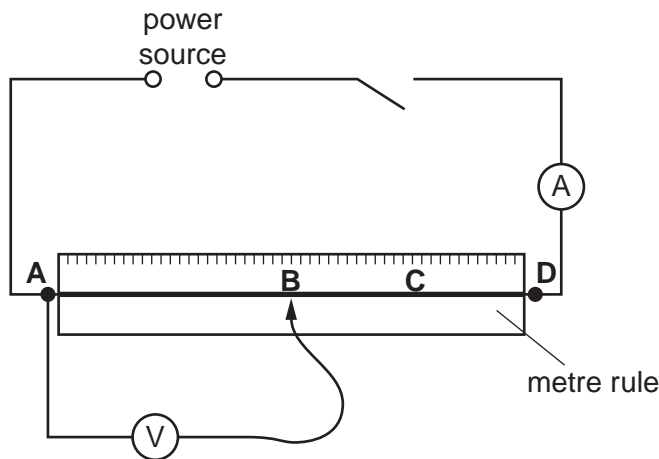

Fig. 3.1

- (a) A student measures the current I in the circuit and the p.d. V across the section of wire **AB**. He records the length l of the wire **AB**. He repeats the procedure with the voltmeter connected across section **AC** of the wire and then with the voltmeter connected across section **AD** of the wire. The readings are shown in Table 3.1.

Table 3.1

voltmeter connected across	$l/$	$I/$	$V/$	$R/$
AB	50	0.21	0.9	
AC	75	0.22	1.4	
AD	100	0.20	1.7	

- (i) Calculate the values of resistance R for each length of wire using the equation $R = \frac{V}{I}$. Enter the values in the table.
- (ii) Complete the column headings in the table. [3]
- (b) It is suggested that the resistance across **AB** should be half the resistance across **AD**. State whether the results support this suggestion and justify your answer with reference to the results.
- statement
- justification
-[2]
- (c) It is known that changes in temperature affect the resistance of the wire. State how you can limit the temperature changes when carrying out this experiment.
-
-[1]

(d) The student wishes to use a lower current so he adds a variable resistor to the circuit.

(i) Draw the standard circuit symbol for a variable resistor.

(ii) On Fig. 3.1, mark with an X a suitable position in the circuit for the variable resistor.

[2]

[Total: 8]

5 The IGCSE class is investigating the current in resistors in a

The circuit is shown in Fig. 3.1 circuit.

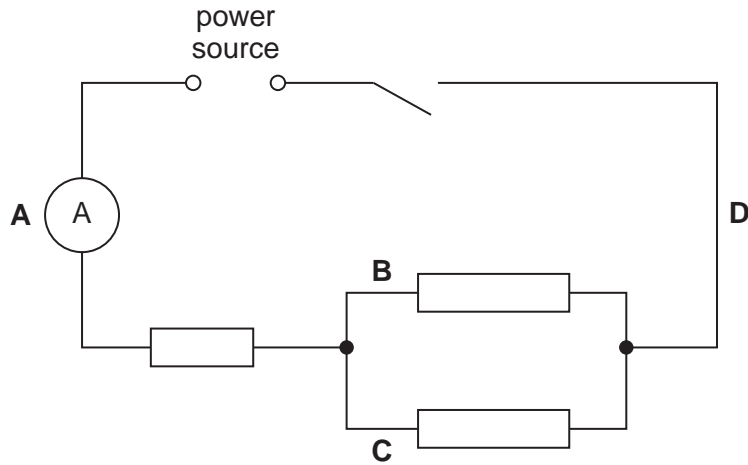

Fig. 3.1

- (a) A student measures the current I_A at the position **A** shown by the ammeter, and then at positions **B** (I_B), **C** (I_C) and **D** (I_D).

The readings are:

$$I_A = 0.28 \text{ A}$$

$$I_B = 0.13 \text{ A}$$

$$I_C = 0.14 \text{ A}$$

$$I_D = 0.27 \text{ A}$$

Theory suggests that $I_A = I_B + I_C$ and $I_D = I_B + I_C$.

- (i) Calculate $I_B + I_C$.

$$I_B + I_C = \dots\dots\dots$$

- (ii) State whether the experimental results support the theory. Justify your statement by reference to the readings.

statement

justification

.....

.....

(b) The student suggests repeating the experiment to confirm her conclusion. She connects a variable resistor (rheostat) in series with the switch. State the purpose of the variable resistor.

.....
.....[1]

(c) The student connects a voltmeter and records the potential difference V across the combination of the three resistors.

(i) On Fig. 3.1, draw in the voltmeter connected as described, using the standard symbol for a voltmeter. [1]

(ii) Write down the voltmeter reading shown on Fig. 3.2.

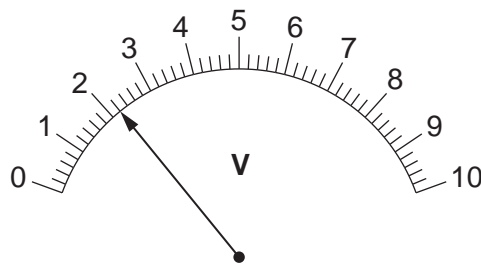

Fig. 3.2

$V =$ [1]

(iii) Calculate the resistance R of the combination of the three resistors using the equation

$$R = \frac{V}{I}$$

$R =$ [2]

[Total: 8]

6 The IGCSE class is investigating the potential difference across resistors in a circuit.

Fig. 3.1 shows the circuit.

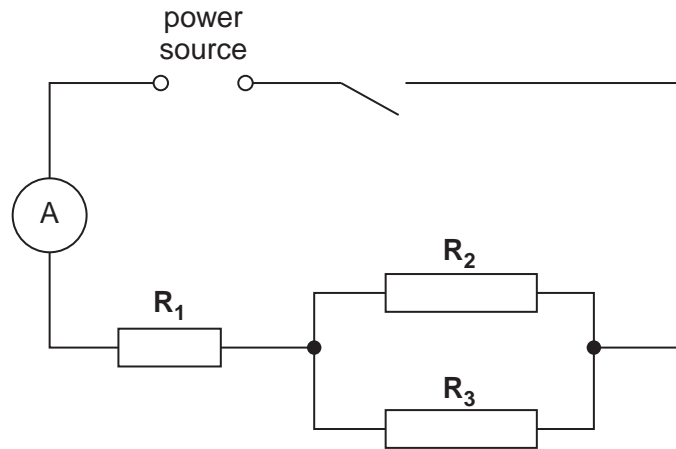

Fig. 3.1

(a) A student measures the potential difference V_A across resistor R_1 .

Write down the reading of V_A shown in Fig. 3.2.

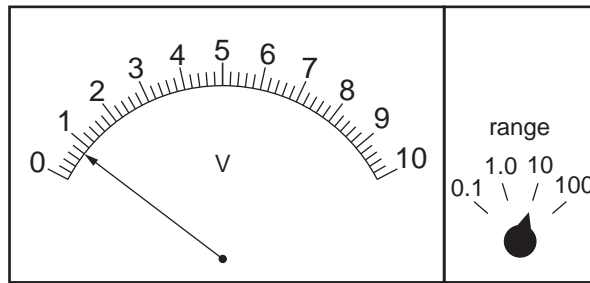

Fig. 3.2

V_A [1]

(b) He then measures the potential difference V_B across resistors R_2 and R_3 and the potential difference V_C across the combination of the three resistors.

The values are: $V_B = 1.4V$ and $V_C = 2.1V$.

Theory suggests that $V_C = (V_A + V_B)$.

(i) Calculate $(V_A + V_B)$.

$(V_A + V_B) =$

- (ii) State whether the experimental results support the theory. Justify your statement by reference to the results.

statement

justification

.....

.....

[3]

- (c) The current I indicated by the ammeter is 0.27 A. Calculate the resistance R of the combination of the three resistors using the equation $R = \frac{V_C}{I}$.

$R =$ [1]

- (d) On Fig. 3.1, draw in the voltmeter connected to measure the potential difference V_B across resistors R_2 and R_3 . Use the standard symbol for a voltmeter. [1]

- (e) Refer to Fig. 3.2. Comment on the student's choice of the 10V range for the measurement of V_A .

.....

.....

.....[1]

[Total: 7]