

Energy Transfers

Question paper 4

| | |
|-------------------|---------------------------------------|
| Level | IGCSE(9-1) |
| Subject | Physics |
| Exam Board | Edexcel IGCSE |
| Module | Single Award (Paper 2P) |
| Topic | Energy resources and energy transfers |
| Sub-Topic | Energy Transfers |
| Booklet | Question paper 4 |

Time Allowed: 53 minutes

Score: /44

Percentage: /100

Grade Boundaries:

| | | | | | | |
|------|------|-----|-----|-----|-----|------|
| A* | A | B | C | D | E | U |
| >85% | '75% | 70% | 60% | 55% | 50% | <50% |

- (b) Hot water from the power station is sprayed into the cooling tower, as shown.
As it falls through the air, some of the hot water evaporates.
The rest of the water is collected and returned as cold water to the power station.

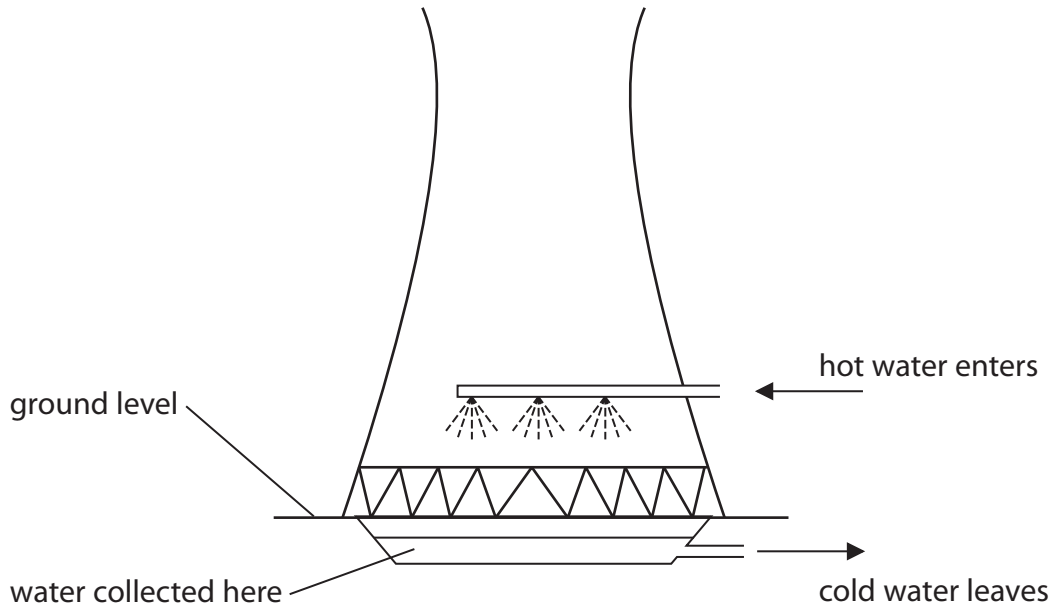

Explain how evaporation cools the water.

(3)

.....

.....

.....

.....

.....

.....

.....

.....

.....

(Total for Question 1 = 7 marks)

2 An electric vehicle has a rechargeable battery.

The battery is recharged by connecting it to a charging station.



© Epattloamer

(a) The battery voltage is 385 V.

(i) State the amount of energy transferred when one coulomb of charge passes through a potential difference of 385 V.

(1)

energy transferred = J

(ii) Show that, when a charge of 180 000 C passes through the battery, the total amount of energy transferred to the battery is about 70 MJ.

(2)

(iii) During the charging process, energy is also transferred to the charging station from the mains supply.

Explain why the amount of energy transferred from the mains supply is more than 70 MJ.

(2)

.....

.....

.....

.....

.....

(b) Charging takes 110 minutes and causes a total charge of 180000 C to pass through the battery.

(i) State the equation linking charge, current and time.

(1)

(ii) Calculate the average charging current in the battery.

(3)

current = A

(Total for Question 2 = 9 marks)

3 A person has a suitcase with wheels.

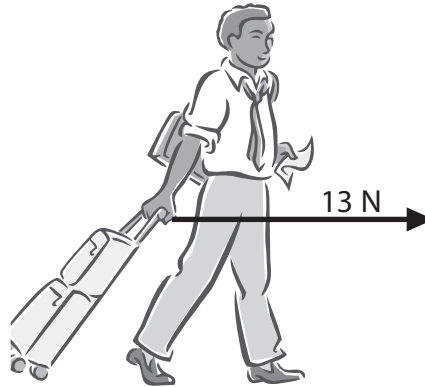

(a) The person pulls the suitcase with a horizontal force of 13 N for 110 m.

(i) State the equation linking work done, force and distance moved.

(1)

(ii) Calculate the work done on the suitcase by the person.

(2)

work done = J

(iii) How much energy is transferred to the suitcase?

(1)

energy transferred = J

(b) The suitcase falls over.



Explain why it loses gravitational potential energy when it falls.

(2)

.....

.....

.....

.....

(c) The person starts to raise the suitcase again by pulling on the handle with force F .

The weight of the suitcase is 150 N.

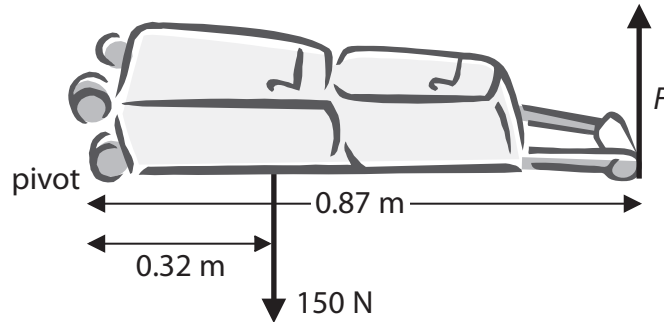

(i) State the equation linking moment, force and perpendicular distance from the pivot.

(1)

.....

(ii) Calculate the force F that the person must apply on the handle to start raising the suitcase.

(3)

force $F =$ N

(Total for Question 3 = 10 marks)

4 A man uses a wheelbarrow to carry some logs along a flat path, as shown.

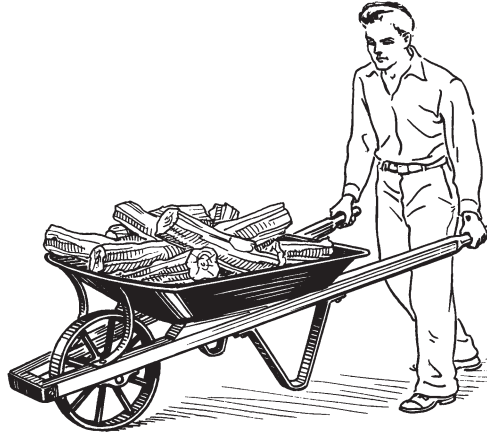

©http://commons.wikimedia.org/wiki/file:wheelbarrow_%28PSF%29.png

(a) He pushes with a horizontal force of 140N and the wheelbarrow moves 39m.

(i) State the relationship between work done, force and distance moved.

(1)

(ii) Calculate the work done moving the wheelbarrow.

(2)

work done = J

(iii) State how much energy is transferred to the wheelbarrow.

(1)

energy transferred = J

(b) The man stops and holds the wheelbarrow horizontally, as shown.

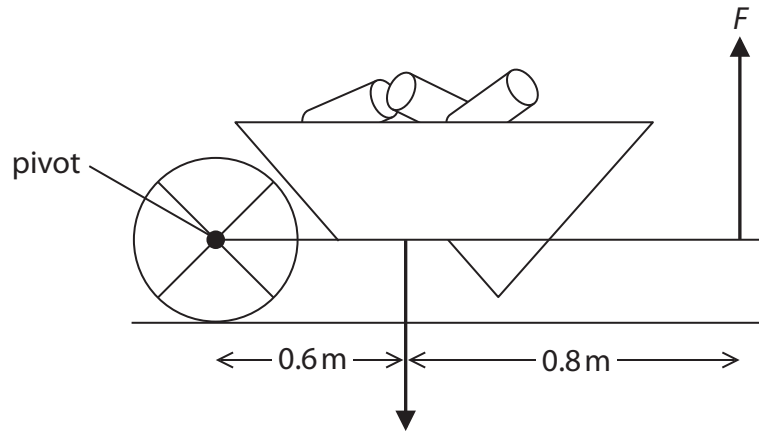

The man exerts a total upward force of F N.

The weight of the loaded wheelbarrow is 470 N.

(i) Mark X on the diagram to indicate the centre of gravity of the loaded wheelbarrow. (1)

(ii) State the equation linking moment, force and perpendicular distance from the pivot. (1)

(iii) Calculate the force F . (4)

force $F = \dots\dots\dots$ N

(Total for Question 4 = 10 marks)

5 (a) Which of these is a unit for energy?

(1)

- A joule
- B kilogram
- C newton
- D watt

(b) The diagram shows a cell connected to a lamp.

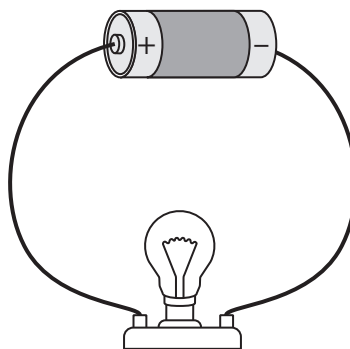

Use words from the box to complete the sentences.

Each word may be used once, more than once, or not at all.

(3)

| | | | |
|----------|--------|---|-----|
| chemical | trical | l | ork |
|----------|--------|---|-----|

The cell converts energy into energy.

The lamp converts this energy into energy and energy.

(c) This is the Sankey energy diagram for a low energy lamp.

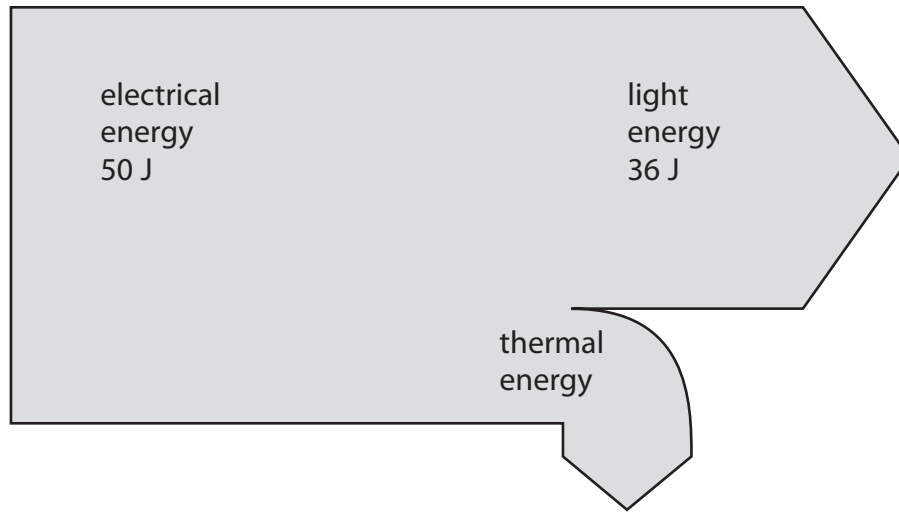

(i) Calculate the amount of thermal energy wasted in the lamp.

(1)

thermal energy = J

(ii) State the equation linking efficiency, useful energy output and total energy input.

(1)

(iii) Calculate the efficiency of the lamp.

(2)

efficiency =

(Total for Question 5= 8 marks)