

Work and Power

Question paper 1

Level	IGCSE(9-1)
Subject	Physics
Exam Board	Edexcel IGCSE
Module	Double Award (Paper 1P)
Topic	Energy resources and energy transfers
Sub-Topic	Work and Power
Booklet	Question paper 1

Time Allowed: 72 minutes

Score: /60

Percentage: /100

Grade Boundaries:

A*	A	B	C	D	E	U
>85%	'75%	70%	60%	55%	50%	<50%

1 The diagram shows an electric motor.

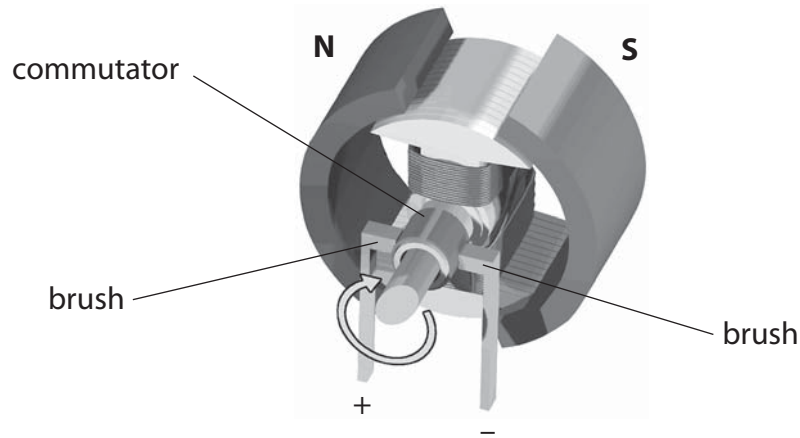

(a) This electric motor needs a direct current (d.c).

(i) Explain what is meant by the term direct current.

(1)

.....

.....

(ii) Explain the purpose of the brushes and the commutator in a d.c. motor.

(3)

.....

.....

.....

.....

.....

.....

(iii) The motor turns clockwise when the direction of the current goes from + to - .

State what happens to the motor when both the magnetic field and the current are reversed.

(1)

.....

.....

(b) The photograph shows a machine at a coal mine.



© Andrew Curtis

The machine lifts up containers of coal from the mine and lowers empty containers down.

The machine uses an electric motor connected to a 600 V d.c. supply.

The maximum current in the motor is 4000 A.

(i) State the equation linking power, current and voltage. (1)

(ii) Calculate the maximum power available from the motor. (2)

maximum power = MW

(c) The machine lifts a load weighing 400 000N through 190m.

(i) State the relationship between work done, force and distance moved. (1)

(ii) Calculate the work done on the load. (2)

work done on load = J

(d) The machine uses an average (mean) power of 1.9MW to do 67 MJ of work.

(i) Calculate the time needed to do this work. (3)

time = s

(ii) State the effect of using a lower average power to do this work. (1)

.....
.....

(Total for Question 1 = 15 marks)

- 2 A flying squirrel is an animal that can glide through the air.
It spreads out its limbs to stretch a membrane that helps it to glide.



© Robert Savannah

- (a) The mass of a flying squirrel is 0.19 kg.

It climbs 17 m up a tree.

- (i) State the equation linking gravitational potential energy (GPE), mass, g and height. (1)

- (ii) Calculate the GPE gained by the squirrel during this climb. (2)

GPE = J

- (iii) State the amount of work done against the force of gravity by the squirrel during this climb. (1)

work done = J

(b) The flying squirrel glides from P to Q with a constant velocity of 13 m/s.

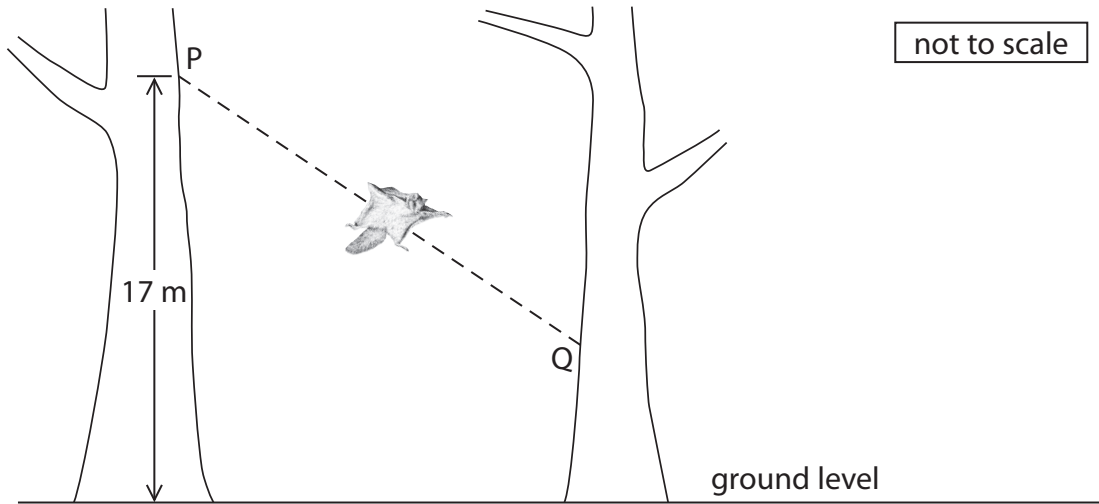

(i) Add labelled arrows to the diagram to show the directions of the forces of weight and drag acting on the squirrel. (2)

(ii) State the equation linking kinetic energy (KE), mass and velocity. (1)

(iii) Calculate the KE of the squirrel as it glides. (2)

KE = J

(iv) The velocity of the squirrel decreases to zero when it reaches the second tree because (1)

- A** an unbalanced force acts on the squirrel
- B** no force acts on the squirrel
- C** the GPE of the squirrel increases
- D** the KE of the squirrel increases

(Total for Question 2 = 10 marks)

- 3 A student investigates how the energies of a ball and spring change when the ball and spring vibrate together.

The diagrams and bar charts show how the energies of the ball and spring vary with the position of the ball.

The ball has a mass of 1 kg.

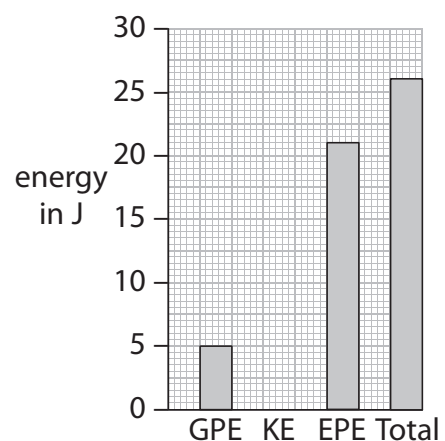
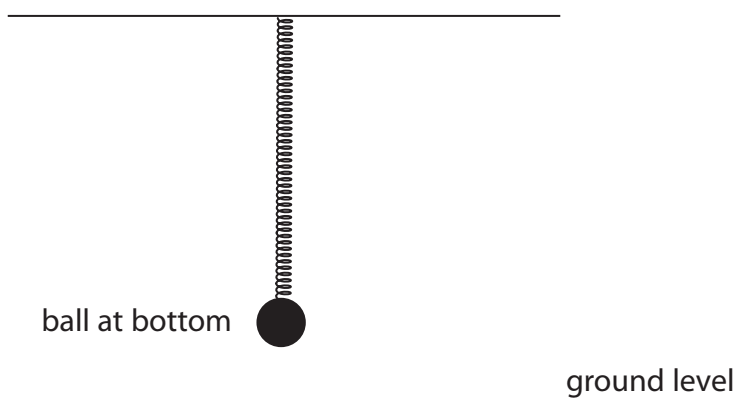
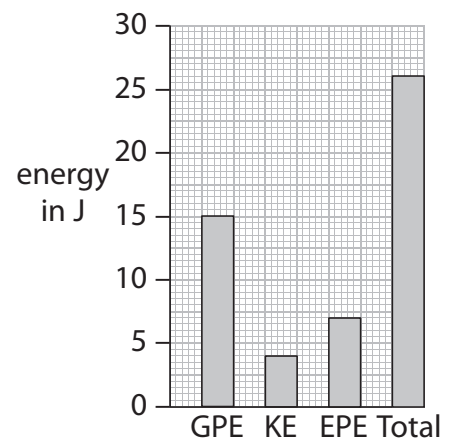
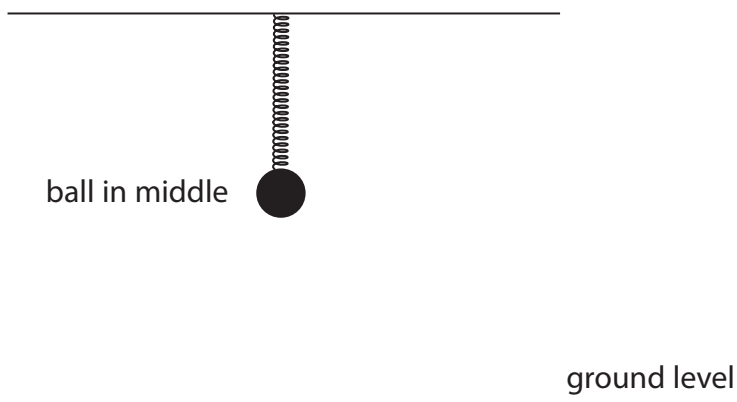
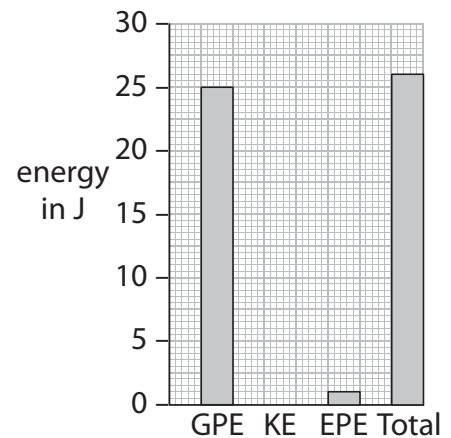
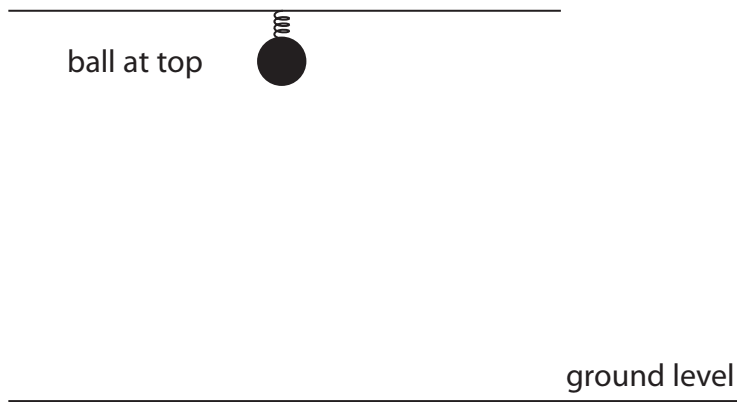

GPE = gravitational potential energy of the ball (zero at ground level)

KE = kinetic energy of the ball

EPE = elastic potential energy of the spring

Use information from the diagrams and the bar charts to describe what happens to the energy, speed and position of the ball as it vibrates on the spring.

(6)

A series of 20 horizontal dotted lines for writing the answer.

(Total for Question 3 = 6 marks)

4 The diagram shows the lighting circuit in an office.

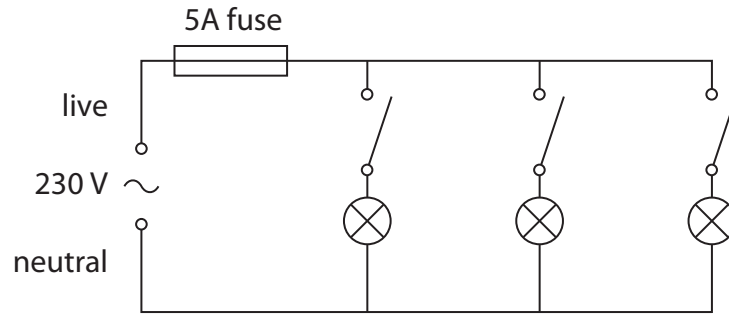

(a) (i) State two advantages of connecting lamps in parallel rather than in series.

(2)

1

.....

2

.....

(ii) What is the purpose of the 5 A fuse?

(1)

.....

.....

(iii) Explain how a fuse works.

(3)

.....

.....

.....

.....

.....

.....

.....

(b) A label on one of the office computers includes this information.

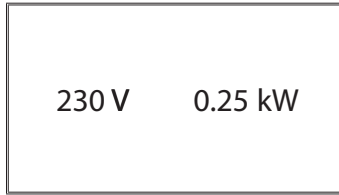

(i) State the equation linking power, current and voltage. (1)

(ii) Use the information on the label to calculate the current in the computer. (3)

current = A

(iii) Fuses are available with values of 1 A, 3 A, 10 A and 13 A.
Suggest the most suitable fuse value for the computer.
Give a reason for your answer. (2)

fuse value A

reason

.....

(iv) Some circuits use a circuit breaker instead of a fuse.

State two advantages of using a circuit breaker instead of a fuse.

(2)

1

.....

2

.....

(c) The graphs show some ways that power (P) can vary with voltage (V).

Which is the correct graph for a fixed resistor?

(1)

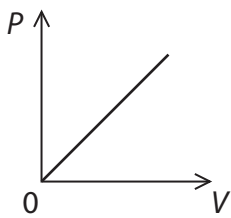

A

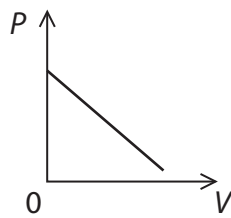

B

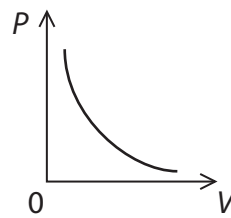

C

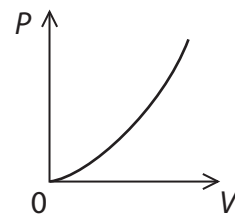

D

(Total for Question 4 = 15 marks)

5 A resistance band is a stretchy plastic band that is used when doing exercises.

The diagram shows a student exercising his leg by stretching a resistance band fixed to a wall.

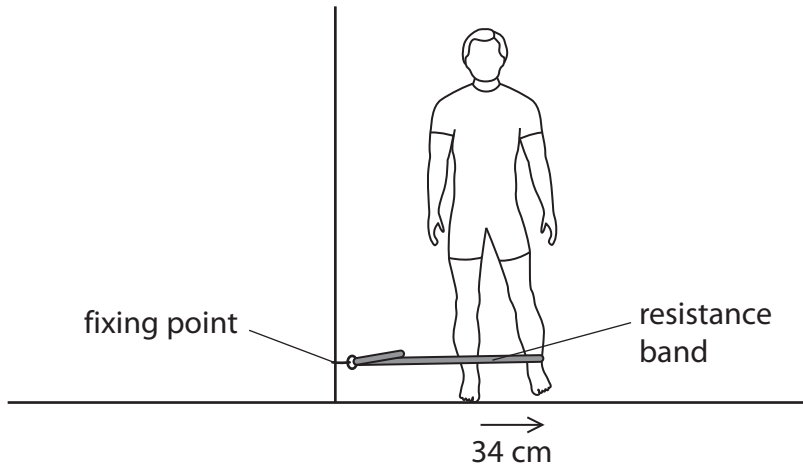

The student moves his leg 34 cm sideways as shown.
The average resistance force is 23 N.

(a) (i) State the relationship between work done, force and distance moved. (1)

(ii) Calculate the work done when the student moves his leg sideways once. (2)

work done = J

(b) The student repeats this movement 15 times in 1 minute.
Calculate the average power of the student during this exercise. (3)

power = W

(Total for Question 5 = 6 marks)

6 The photograph shows an extension cable on a reel.



There is a warning label on the reel.

WARNING
maximum allowable power
when cable fully extended – 2400 W, 240 V
when cable coiled up – 700 W, 240 V

(a) (i) State the equation linking power, current and voltage.

(1)

(ii) Complete the table by inserting the missing value.

(1)

Power in W	Voltage in V	Current in A
700	240	
2400	240	10

(b) The extension cable is fitted with a 13 A fuse.

(i) Describe how the fuse protects the cable.

(3)

.....

.....

.....

.....

.....

.....

(ii) Explain why a 5 A fuse is **not** suitable for this extension cable.

(2)

.....

.....

.....

.....

(iii) Suggest why the maximum recommended current is lower when the cable is coiled up.

(1)

.....

.....

.....

(Total for Question 6 = 8 marks)