

# Magnetism

## Question paper 1

|                   |                                |
|-------------------|--------------------------------|
| <b>Level</b>      | IGCSE(9-1)                     |
| <b>Subject</b>    | Physics                        |
| <b>Exam Board</b> | Edexcel IGCSE                  |
| <b>Module</b>     | Double Award (Paper 1P)        |
| <b>Topic</b>      | Magnetism and Electromagnetism |
| <b>Sub-Topic</b>  | Magnetism                      |
| <b>Booklet</b>    | Question paper 1               |

**Time Allowed:** 72 minutes

**Score:** /60

**Percentage:** /100

**Grade Boundaries:**

|      |      |     |     |     |     |      |
|------|------|-----|-----|-----|-----|------|
| A*   | A    | B   | C   | D   | E   | U    |
| >85% | '75% | 70% | 60% | 55% | 50% | <50% |

1 Magnetic fields can have different shapes.

(a) (i) Describe an experiment to show the shape of the magnetic field around a bar magnet.

(2)

.....

.....

.....

.....

.....

.....

(ii) The diagram shows a bar magnet.

Complete the diagram to show the shape of the field around the magnet.

(2)

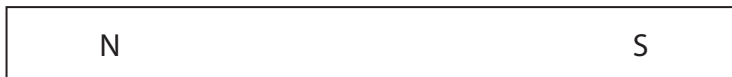

(b) The diagram shows two bar magnets.

They produce a uniform magnetic field.

On the diagram, sketch the part of the field that is uniform and label the poles.

**(3)**



**(Total for Question 1 = 7 marks)**

- 2 Diagram 1 shows some of the apparatus used to investigate the force on a current-carrying wire, XY, in a magnetic field.

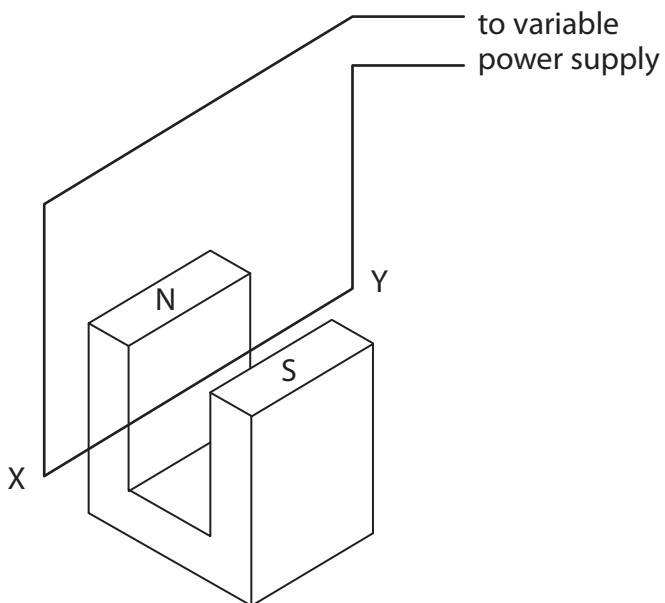

Diagram 1

- (a) Diagram 2 shows the poles of the magnet viewed from above.

Draw the uniform magnetic field between the poles.

(2)



Diagram 2

(b) The current-carrying wire XY is at right angles to the magnetic field.

The current in the wire is 10 A.

(i) Suggest why the wire used in this investigation must be thick.

(1)

.....  
.....

(ii) Explain why the wire XY experiences a force when there is a current in the circuit.

(3)

.....  
.....  
.....  
.....  
.....  
.....

(iii) State two ways in which this force can be reduced.

(2)

1 .....

2 .....

.....

---

**(Total for Question 2 = 8 marks)**

3 The diagram shows a piece of card and two wide bar magnets.

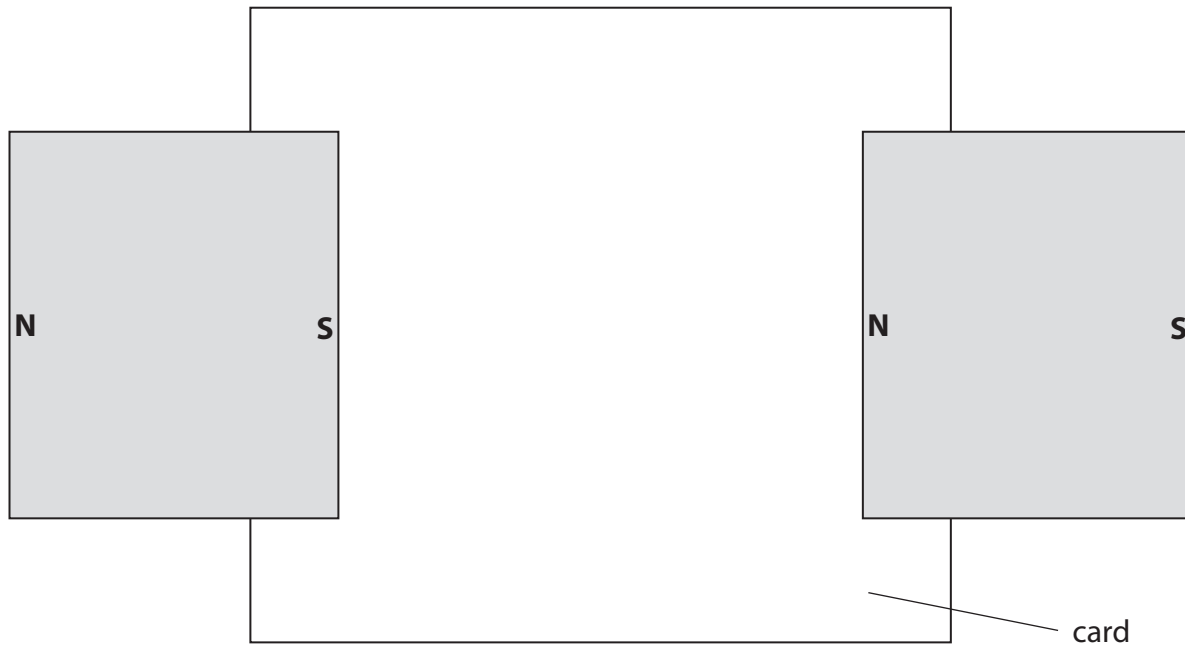

(a) (i) Add to the diagram to show the shape and direction of the magnetic field pattern between the magnets.

(3)

(ii) Describe how to investigate the shape and direction of the magnetic field between the magnets.

(3)

.....

.....

.....

.....

.....

.....

.....

.....

.....

(b) A metal rod, XY, is placed in a magnetic field as shown.

Wires from a cell are connected to the ends of the rod so that there is a current from X to Y.

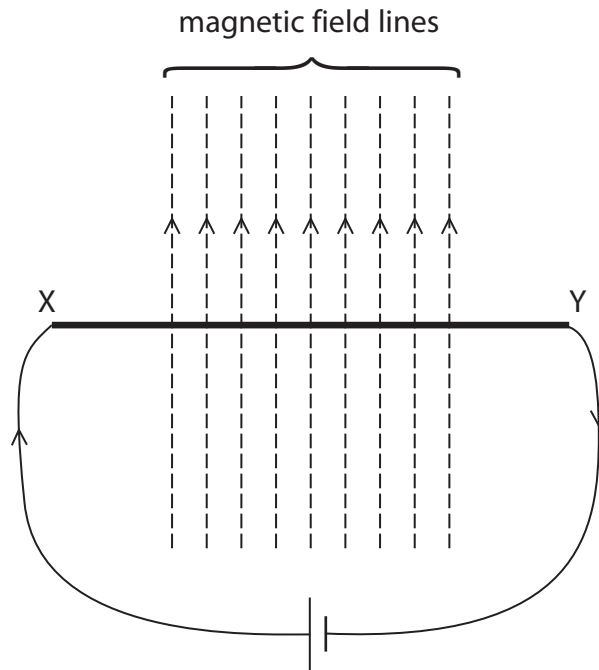

Describe the effect on the rod.

(2)

---

(Total for Question 3 = 8 marks)

4 The photograph shows a simple d.c. electric motor.

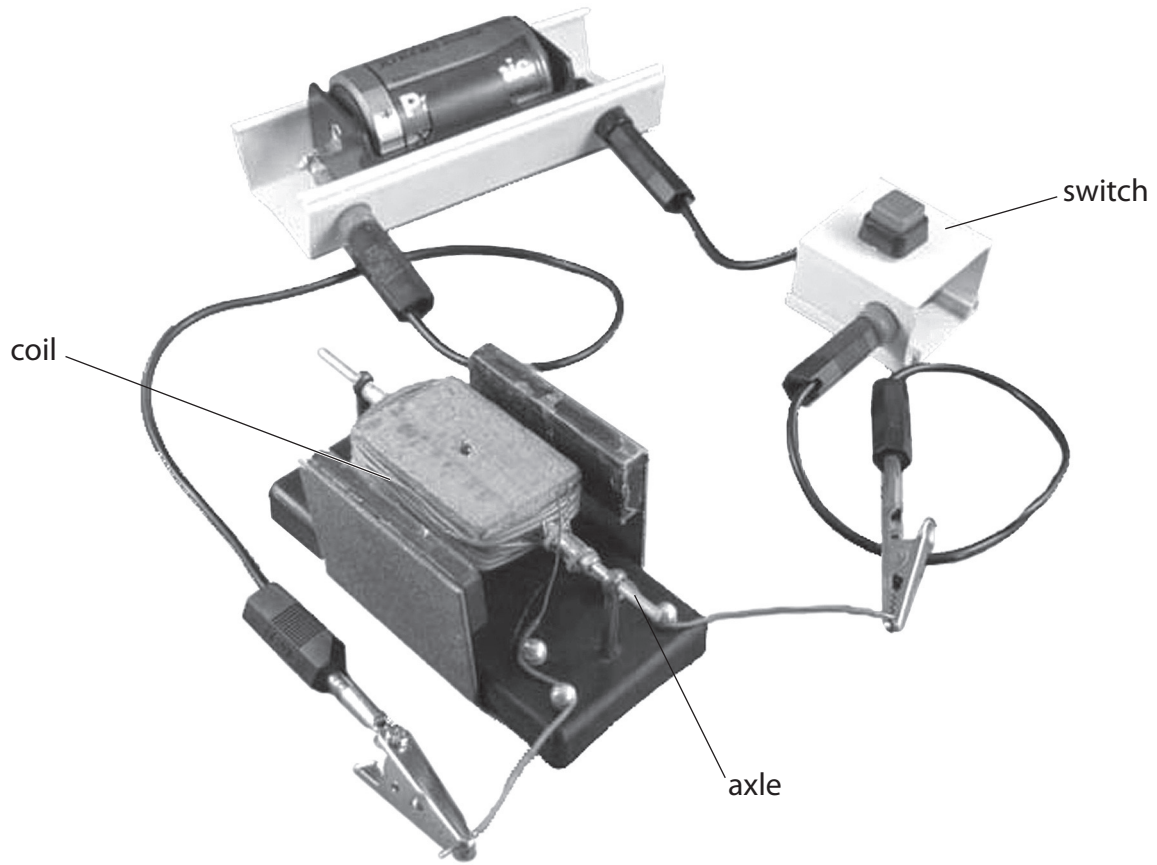

(a) When the switch is closed the coil spins.

Explain why this happens.

(3)

.....

.....

.....

.....

.....

.....

.....

.....

.....



(b) (i) Describe two ways to increase the speed of rotation of the coil in this motor. (2)

1 .....

.....

2 .....

.....

(ii) Suggest how to make the coil spin in the opposite direction. (1)

.....

.....

(c) In a different motor, the magnets are curved and there is a piece of iron inside the coil. The iron increases the strength of the magnetic field through the coil.

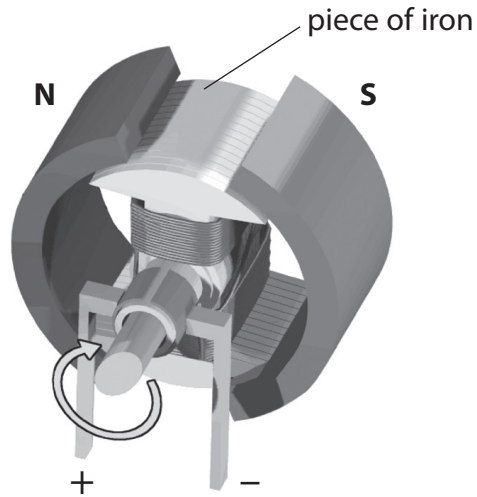

Suggest how the curved magnets and the piece of iron improve the performance of the electric motor. (2)

.....

.....

.....

.....

.....

.....

5 The diagram shows a magnet held above a coil. The coil is connected to a voltmeter.

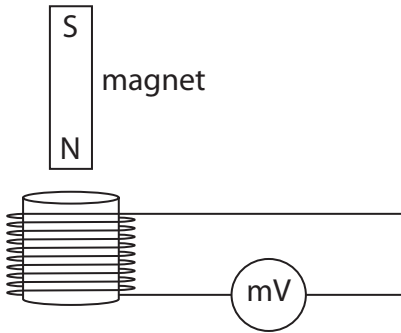

(a) The magnet is released and falls into the coil.

(i) Explain why the voltmeter shows a reading.

(2)

.....

.....

.....

.....

(ii) The magnet is released from a greater height.

How does this affect the voltmeter?

Explain your answer.

(2)

.....

.....

.....

.....

(b) State how the voltmeter reading changes when the same magnet

(i) moves more slowly into the coil

(1)

---

(ii) moves into a coil with more turns

(1)

---

(iii) is reversed so that the S-pole enters the coil first.

(1)

---

**(Total for Question 5 = 7 marks)**

6 The diagram shows the magnetic field pattern around a bar magnet.

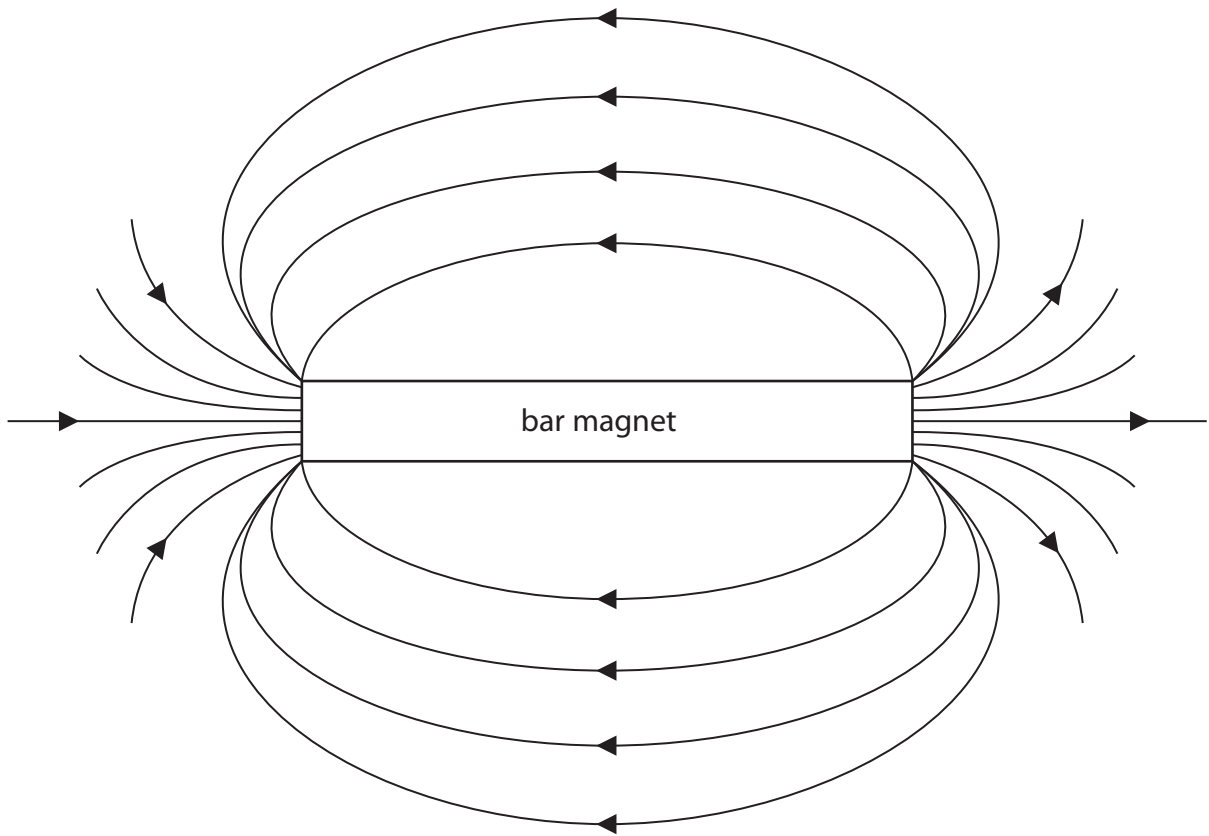

(a) Complete the diagram above by labelling the poles on the bar magnet.

(2)

(b) Describe an experiment to investigate the shape of the magnetic field pattern of a bar magnet.

You may draw a diagram to help your answer.

(3)

.....

.....

.....

.....

.....

.....

**(Total for Question 6 = 5 marks)**

7 A magnetic field pattern can be shown using lines.

(a) The diagram shows some magnetic field patterns.

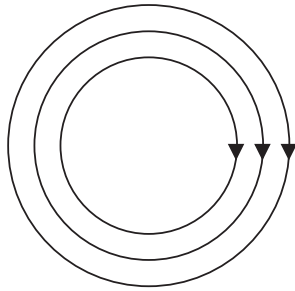

A

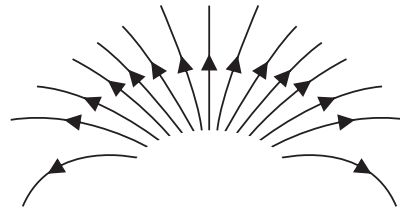

B

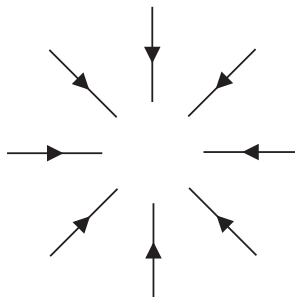

C

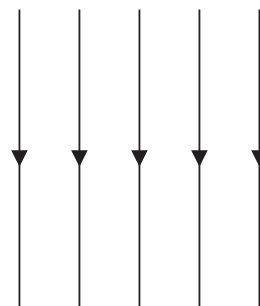

D

Which pattern shows a **uniform** magnetic field? Explain your answer.

(2)

Pattern .....

Explanation .....

.....  
.....

(b) Explain how to produce a uniform magnetic field.

(3)

.....  
.....  
.....  
.....  
.....  
.....

8 (a) All metals are good conductors of electricity.

Which of these non-metals can conduct electricity?

- A carbon
- B chalk
- C plastic
- D rubber

(b) The current in a metallic conductor is a flow of

- A negatively charged electrons
- B negatively charged protons
- C positively charged electrons
- D positively charged protons

(c) Some metals and alloys are magnetic.

Which of these is magnetic?

- A aluminium
- B copper
- C gold
- D steel

(d) Which of these field patterns is correct?

(1)

A

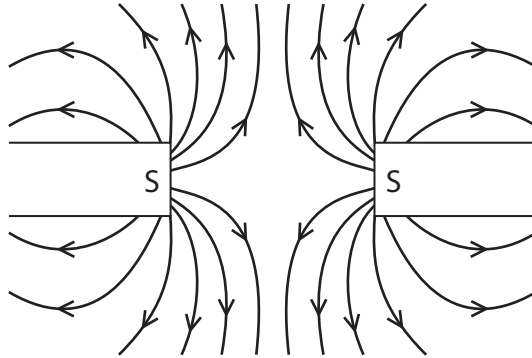

B

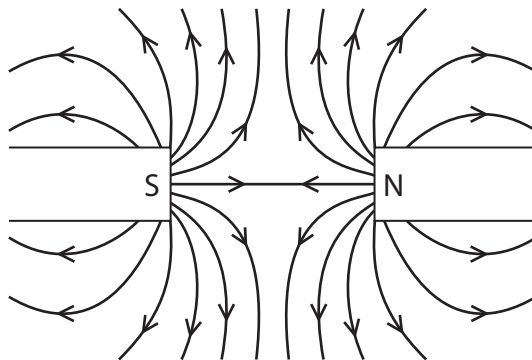

C

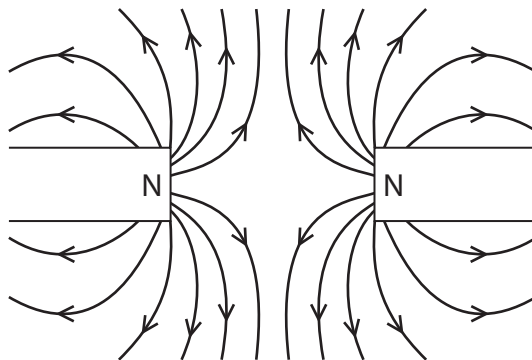

D

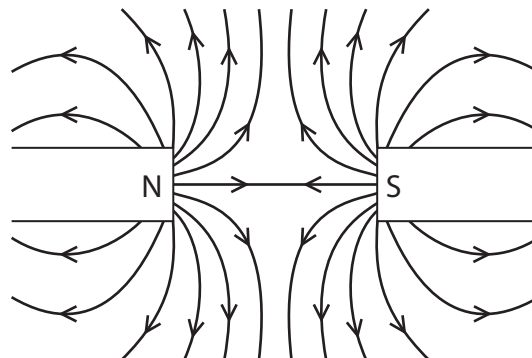

(Total for Question 8 = 4 marks)



9 A student investigates how to produce a voltage.

He hangs a magnet from a spring, above a coil that is connected to a data logger.

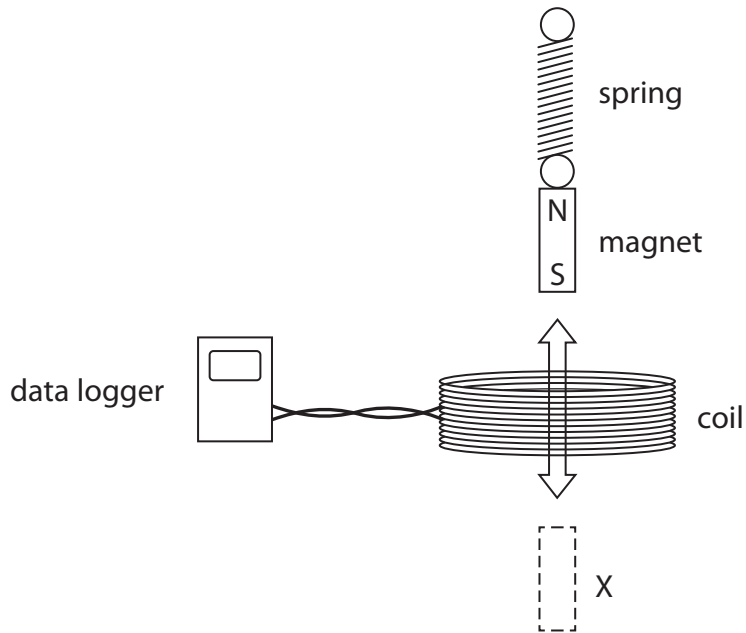

(a) The student pulls the magnet through the coil to X and then releases it.

The magnet moves up and down through the coil.

The data logger produces this graph of voltage against time.

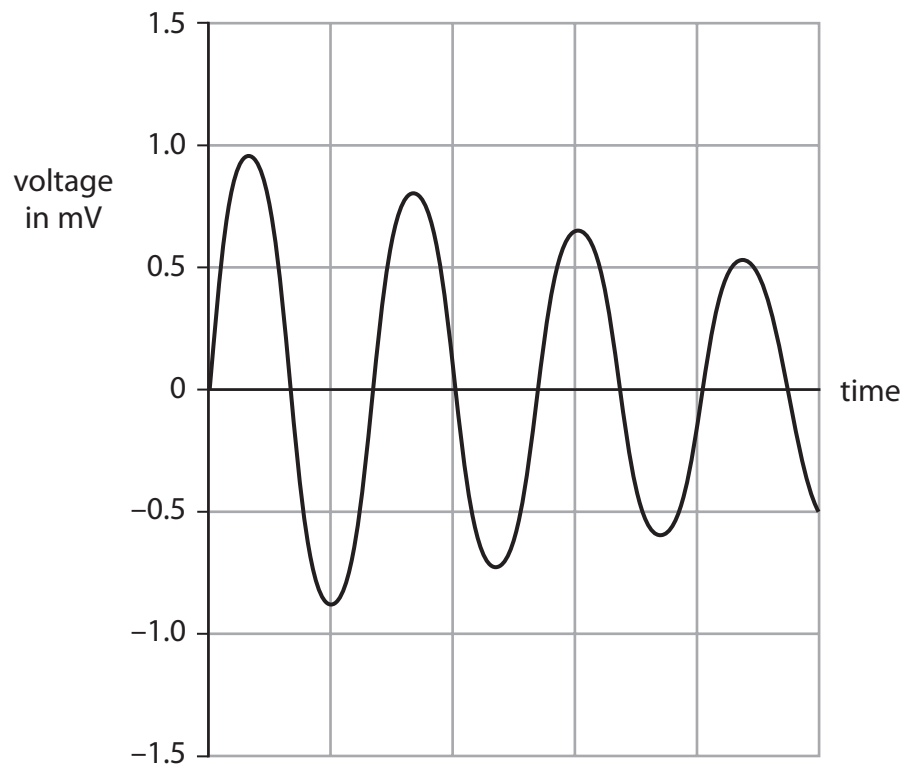

(i) Explain why the data logger records a varying voltage.

(2)

.....

.....

.....

.....

(ii) Which feature of the graph shows that the voltage is alternating?

(1)

.....

.....

.....

(iii) Suggest why the voltage changes as shown by the graph.

(2)

.....

.....

.....

.....

(b) The student repeats the experiment using two magnets taped together.

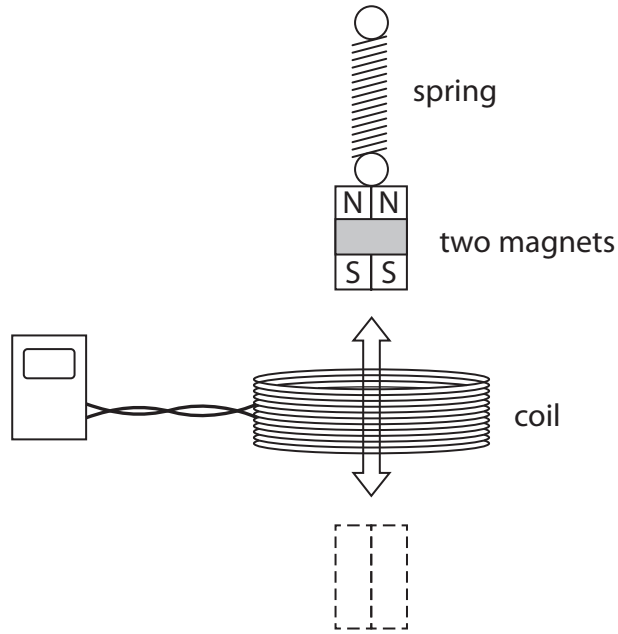

Compared to one magnet, these two magnets take a longer time to move up and down.

The dotted line on the grid shows the original graph for one magnet.

On the same grid, sketch the graph that would be produced using two magnets.

(3)

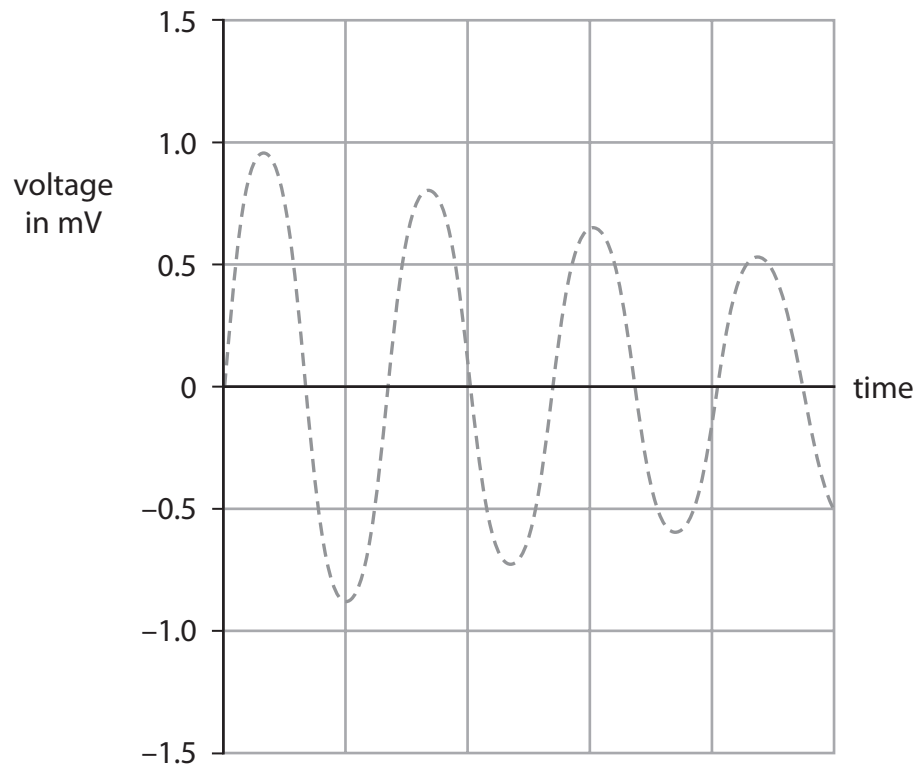

(Total for Question 9 = 8 marks)