

# The Organisms in the Environment

## Question paper 1

<b>Level</b>	IGCSE(9-1)
<b>Subject</b>	Biology
<b>Exam Board</b>	Edexcel IGCSE
<b>Module</b>	Double Award (Paper 1B)
<b>Topic</b>	Ecology and the Environment
<b>Sub-Topic</b>	The Organisms in the Environment
<b>Booklet</b>	Question paper 1

**Time Allowed:** 63 minutes

**Score:** /52

**Percentage:** /100

**Grade Boundaries:**

9	8	7	6	5	4	3	2	1
>90%	80%	70%	60%	50%	40%	30%	20%	10%

- 1 A student wanted to investigate the factors that influence the activity of soil organisms in a woodland. She decided to study one species of woodlouse, a small animal found under stones and rotting wood in damp and dark places.

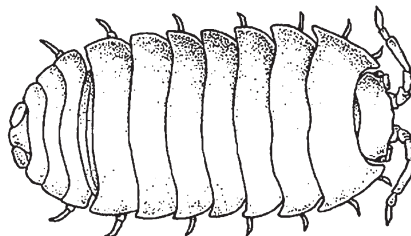

She used a trap to collect organisms in the woodland during the day time and during the night time.

She counted the organisms collected before releasing them.

**Day time sample**

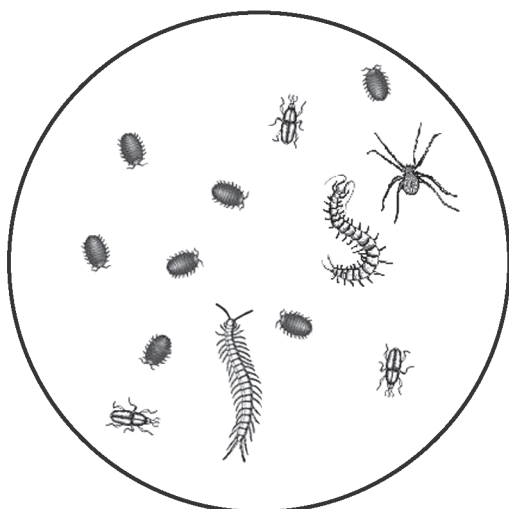

**Night time sample**

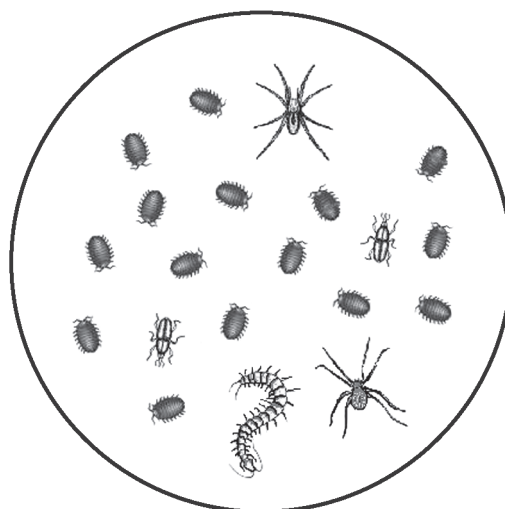

From the day time sample she produced a table of results.

Organism	Tally	Number
woodlice		7
spiders		1
centipedes		2
beetles		3

(a) Complete the table below to show the results for the night time sample.

(2)

Organism	Tally	Number
woodlice		
spiders		
centipedes		
beetles		

(b) Use the data from the day time and night time samples to draw a bar chart to compare the number of organisms collected.

(5)

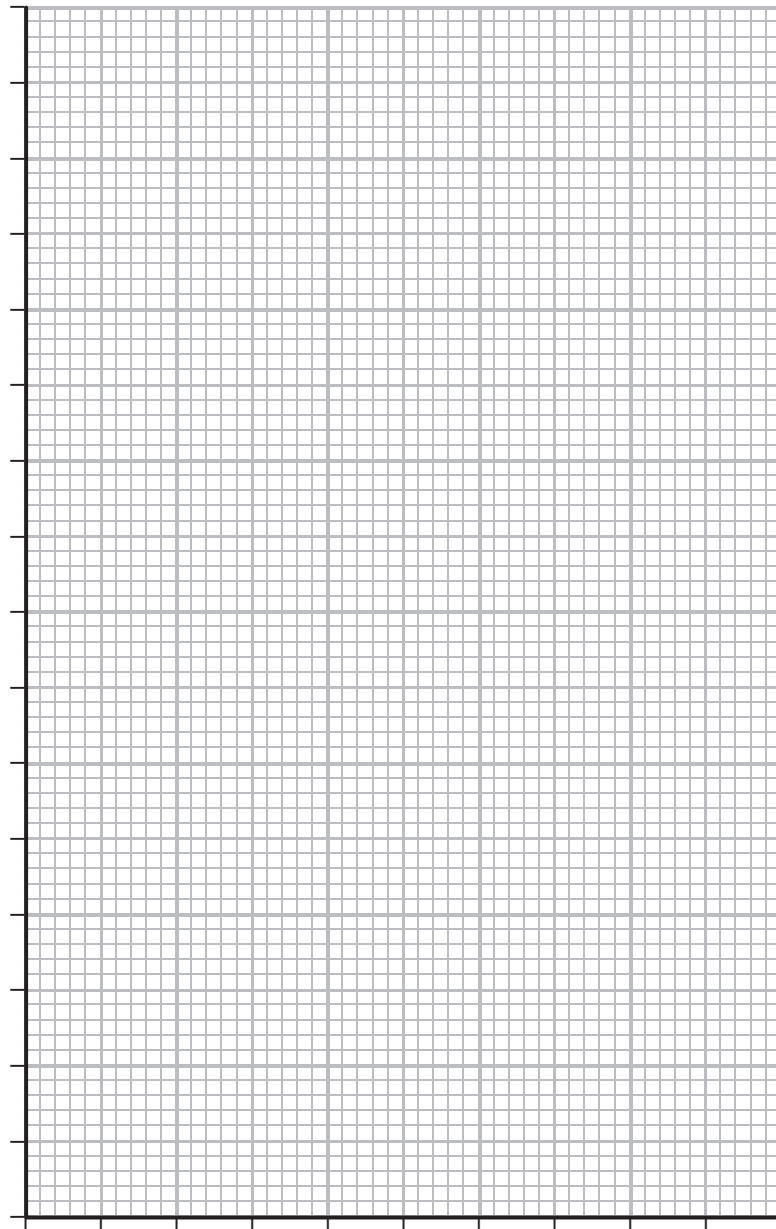

(c) (i) Compare the number of organisms collected during the day time and during night time.

(3)

.....

.....

.....

.....

.....

.....

.....

.....

.....

(ii) Suggest an explanation for the change in the numbers of woodlice.

(2)

.....

.....

.....

.....

.....

.....

.....

.....

(d) The organisms caught in the trap remained there for up to 10 hours before being counted.

Suggest how this might affect the results obtained.

(2)

.....

.....

.....

.....

.....

.....

.....

.....

(e) Ecology involves the study of organisms in their environment.

With reference to the investigation in this question, explain the terms

(i) population

(1)

.....

.....

.....

(ii) community

(1)

.....

.....

.....

(iii) habitat

(1)

.....

.....

.....

---

**(Total for Question = 17 marks)**



- 3 Different plant species in the UK release pollen in the air. This pollen may land on people causing an allergic reaction called hay fever.

For this reason, daily pollen counts are carried out in some cities and the results are used to advise people who have allergic reactions when to stay inside their houses.

The diagram shows how the size of the pollen count varies for each species. It also shows the months when the pollen from each species is released into the air.

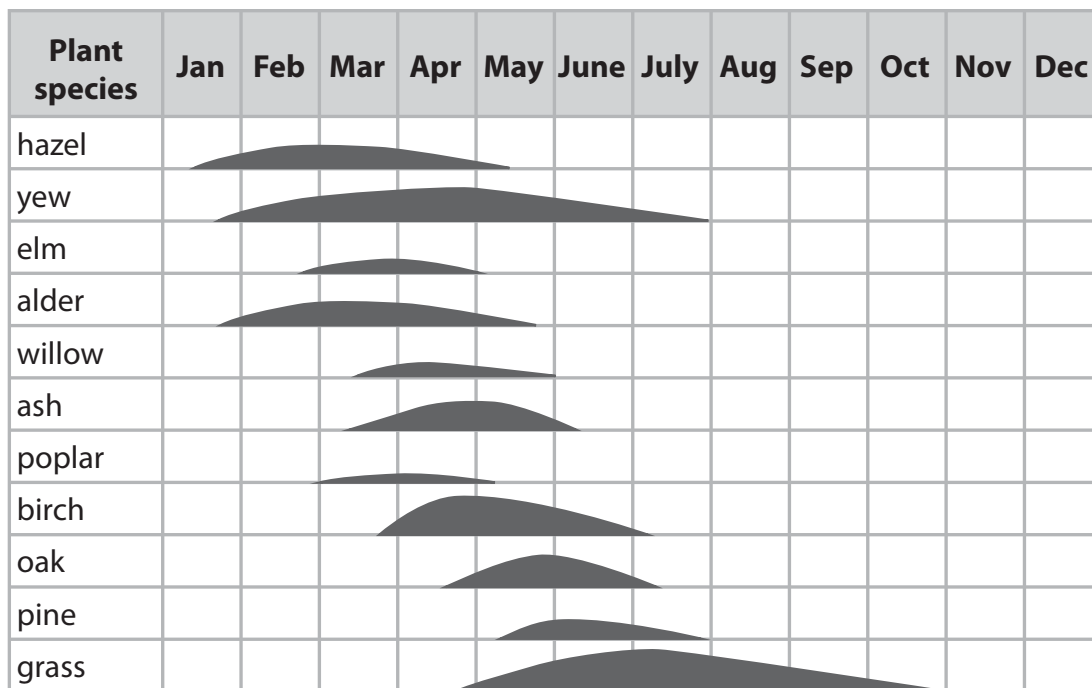

- (a) (i) In which months is there no risk of hay fever? (1)

.....

- (ii) Explain which plant species is likely to have the greatest effect of causing hay fever. (2)

.....  
 .....  
 .....  
 .....





- 4 The photograph shows an insect called a fire ant.  
These insects are a pest because their bite is painful.



Scientists compared two different methods for reducing the population of fire ants in the USA.

In the first method the scientists treated an area with pesticide.

In the second method they released an organism that killed fire ants by biological control.

They then estimated the number of fire ants every 6 months for a period of 30 months.

The table shows the results of their investigation.

Time after treatment in months	Percentage of fire ant population remaining after different treatments	
	Pesticide treatment	Biological control treatment
0	100	100
6	18	2
12	12	5
18	18	2
24	30	2
30	44	4

- (a) Plot a line graph to show the change in population of fire ants when pesticide was used and when biological control was used. Join the points with straight lines.

(6)

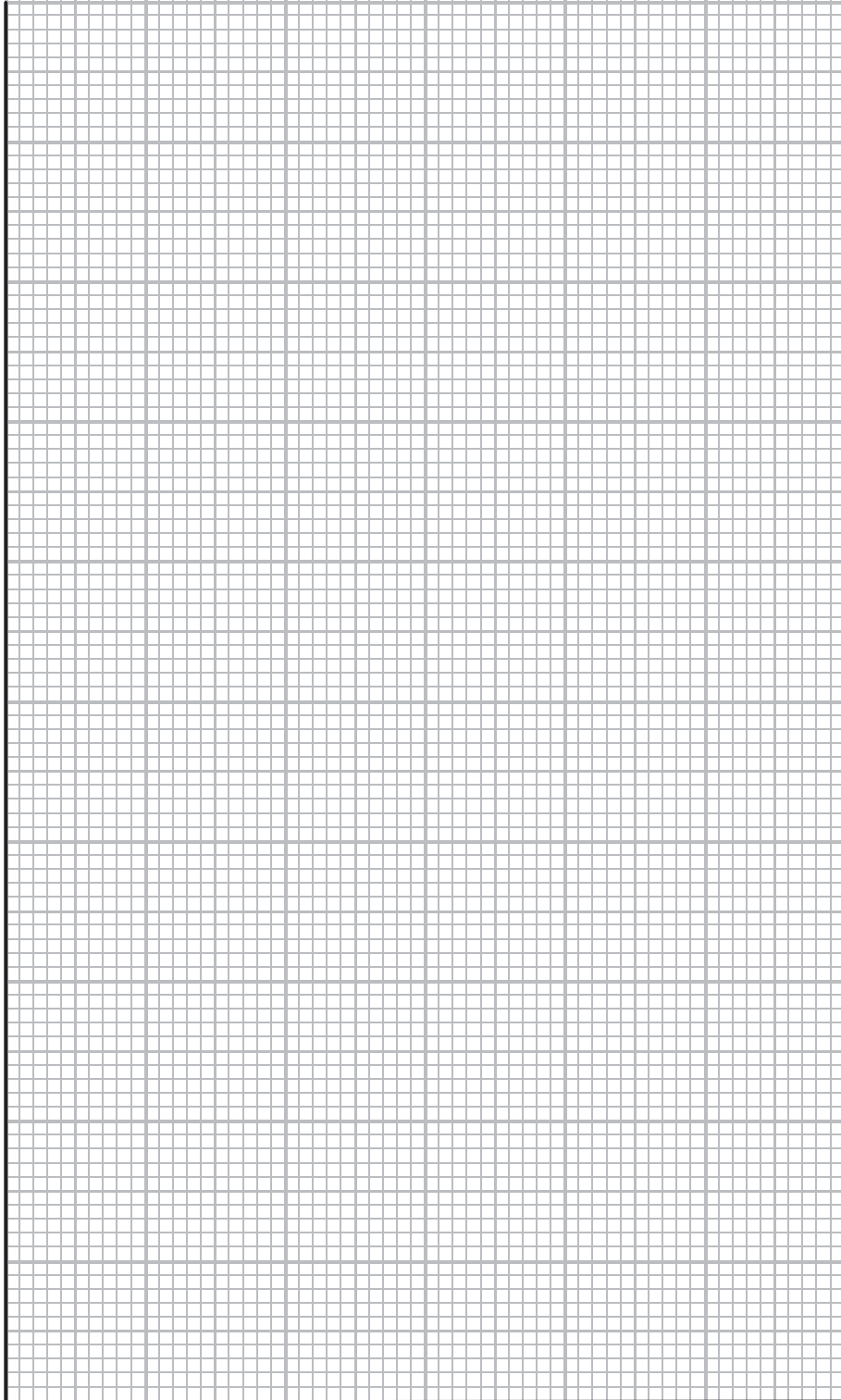



- 5 Three students were asked to estimate the population size of a plant species in an area by using a quadrat.

The diagram shows where each student placed their quadrat in the area.

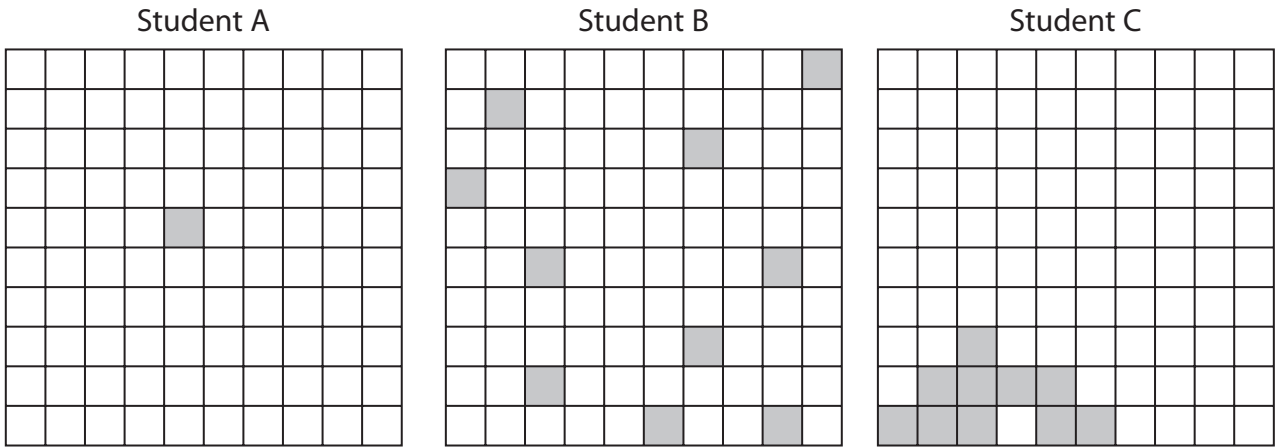

- (a) (i) Which student would obtain the most reliable estimate?

Give reasons for your answer.

(2)

.....

.....

.....

.....

- (ii) State what is meant by the term **population**.

(1)

.....

.....

- (b) Five other students investigated the distribution of grass in the goal area of a football pitch.

They placed a small quadrat at the goal line and then at one metre intervals in a straight line away from the goal line. The diagram shows their method.

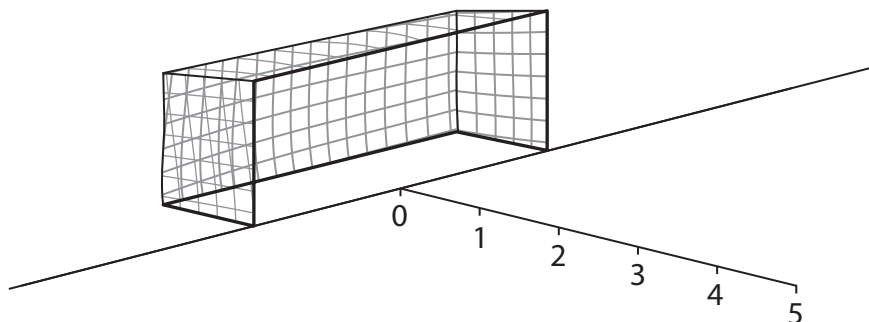

The quadrat was 10 cm by 10 cm and was made from clear plastic. It was marked into 100 squares of 1 cm x 1 cm. If grass could be seen in 10 of the squares the percentage cover would get a score of 10%.

The table shows the results obtained by the five students.

Student	Percentage cover of grass at different distances from the goal line					
	0 m	1 m	2 m	3 m	4 m	5 m
A	14	14	38	41	90	100
B	20	13	5	47	82	90
C	15	14	45	50	86	85
D	10	18	35	50	75	83
E	10	15	30	50	70	90
average	14	15	37	48	81	90

- (i) One of the averages of the results has been calculated ignoring an anomalous result.  
Which student obtained the anomalous result?

(1)

- (ii) The diagram shows a quadrat used by one of the students, and the number of 1cm squares where grass can be seen.

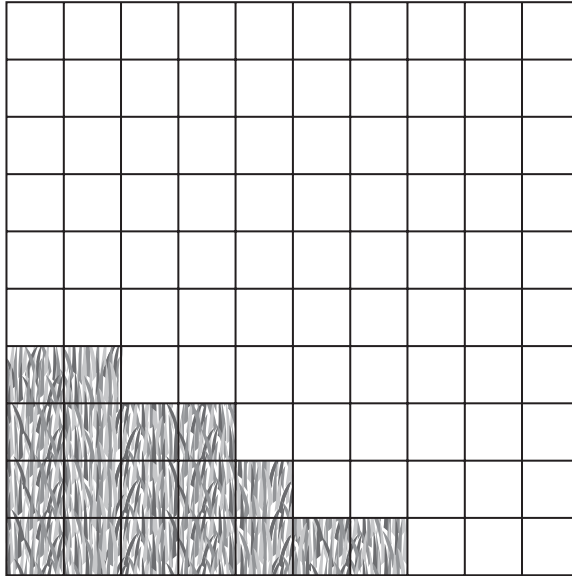

Which student obtained the results shown in this quadrat?

(1)

---

(Total for Question = 5 marks)