

Please check the examination details below before entering your candidate information

Candidate surname

Other names

Pearson Edexcel
International
Advanced Level

Centre Number

--	--	--	--	--

Candidate Number

--	--	--	--	--

Monday 13 January 2020

Afternoon (Time: 1 hour 45 minutes)

Paper Reference **WCH14/01**

Chemistry

International Advanced Level

Unit 4: Rates, Equilibria and Further Organic Chemistry
(including synoptic assessment)

Candidates must have: Scientific calculator
Data Booklet
Ruler

Total Marks

Instructions

- Use **black** ink or **black** ball-point pen.
- **Fill in the boxes** at the top of this page with your name, centre number and candidate number.
- Answer **all** questions.
- Answer the questions in the spaces provided – *there may be more space than you need.*

Information

- The total mark for this paper is 90.
- The marks for **each** question are shown in brackets – *use this as a guide as to how much time to spend on each question.*
- In the question marked with an **asterisk** (*), marks will be awarded for your ability to structure your answer logically, showing how the points that you make are related or follow on from each other where appropriate.
- A Periodic Table is printed on the back cover of this paper.

Advice

- Read each question carefully before you start to answer it.
- Show all your working in calculations and include units where appropriate.
- Check your answers if you have time at the end.

Turn over ►

P60472A

©2020 Pearson Education Ltd.

1/1/1/1/



Pearson

SECTION A

Answer ALL the questions in this section.

You should aim to spend no more than 20 minutes on this section.

For each question, select one answer from A to D and put a cross in the box ☒. If you change your mind, put a line through the box ☒ and then mark your new answer with a cross ☒.

- 1 This question is about four organic compounds each with five carbon atoms but different functional groups.

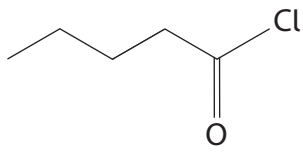
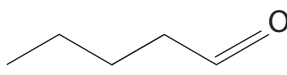
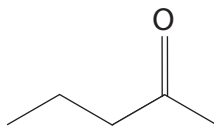
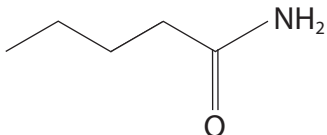
Compound	Skeletal formula
1	
2	
3	
4	

- (a) Which of these, when mixed with water, produces the solution with the **lowest** pH?

(1)

- A compound 1
- B compound 2
- C compound 3
- D compound 4

DO NOT WRITE IN THIS AREA

DO NOT WRITE IN THIS AREA

DO NOT WRITE IN THIS AREA



(b) Which of these reacts with ethylamine, $\text{CH}_3\text{CH}_2\text{NH}_2$, to form an N-substituted amide? (1)

- A compound 1
- B compound 2
- C compound 3
- D compound 4

(c) Which of these reacts with iodine and sodium hydroxide in solution to produce a pale yellow precipitate? (1)

- A compound 1
- B compound 2
- C compound 3
- D compound 4

(Total for Question 1 = 3 marks)

2 Which of these molecules can rotate the plane of plane-polarised light?

- A $\text{H}_2\text{NCH}_2\text{COOH}$
- B $\text{HOCH}_2\text{CH}_2\text{COOH}$
- C $\text{ClCH}_2\text{C}(\text{CH}_3)(\text{Cl})\text{COOH}$
- D $\text{H}_2\text{NC}(\text{CH}_3)_2\text{COOH}$

(Total for Question 2 = 1 mark)

3 A polymer is prepared by the reaction between hexanedioyl dichloride and hexane-1-6-diamine.

What type of polymerisation occurs?

- A addition
- B condensation
- C hydrolysis
- D substitution

(Total for Question 3 = 1 mark)

DO NOT WRITE IN THIS AREA

DO NOT WRITE IN THIS AREA

DO NOT WRITE IN THIS AREA



4 The compound $\text{HOOCCH}=\text{CHCOOH}$ reacts with excess sodium hydroxide solution.

What is the organic product formed in the reaction?

- A $\text{NaOOCCH}=\text{CHCOONa}$
- B $\text{HOOCCH}=\text{CHCOONa}$
- C $\text{NaOOC}(\text{OH})\text{HC}(\text{OH})\text{HCOONa}$
- D $\text{NaOOCCH}=\text{CHCHO}$

(Total for Question 4 = 1 mark)

Use this space for any rough working. Anything you write in this space will gain no credit.

DO NOT WRITE IN THIS AREA

DO NOT WRITE IN THIS AREA

DO NOT WRITE IN THIS AREA



5 Which diagram shows the mechanism for the second order reaction between 1-bromoethane and potassium hydroxide in aqueous solution?

Diagram 1

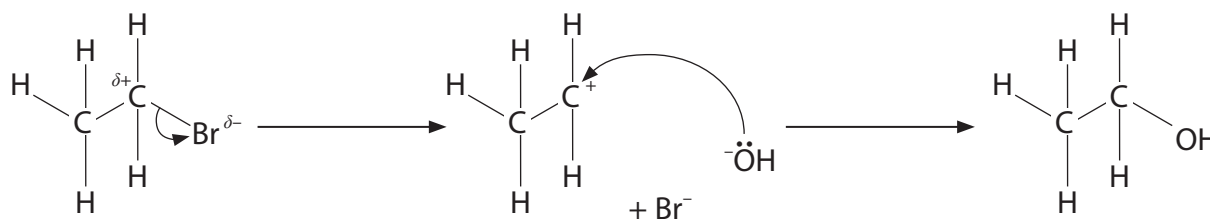

Diagram 2

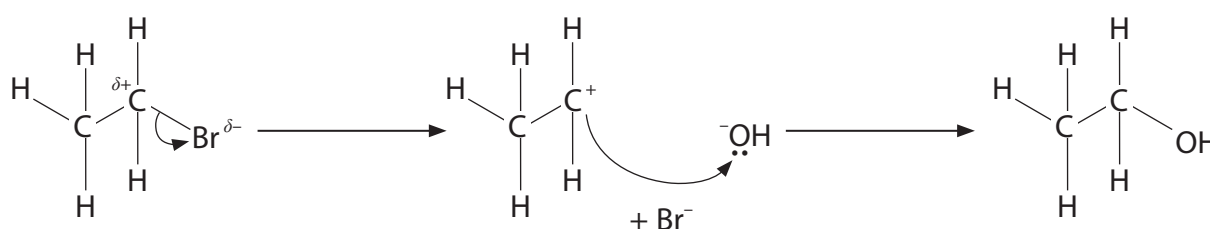

Diagram 3

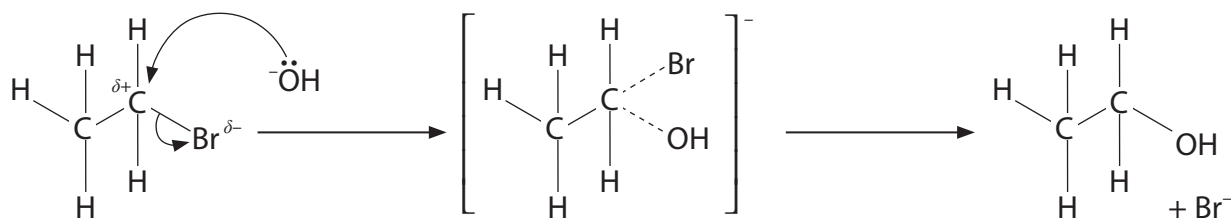
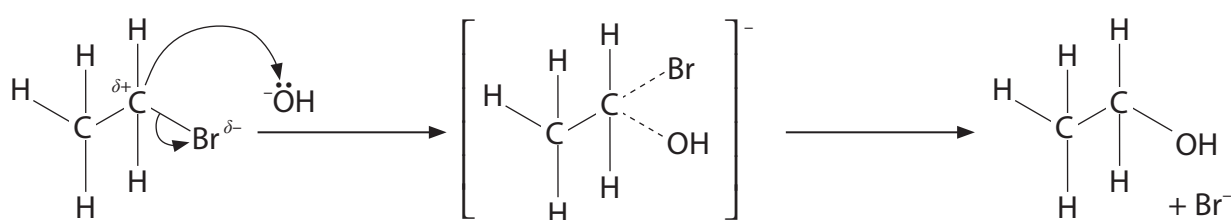

Diagram 4



- A Diagram 1
- B Diagram 2
- C Diagram 3
- D Diagram 4

(Total for Question 5 = 1 mark)



DO NOT WRITE IN THIS AREA

DO NOT WRITE IN THIS AREA

DO NOT WRITE IN THIS AREA

6 Which of these reacts directly with ethanoic acid to form ethanoyl chloride?

- A chlorine
- B chloroethane
- C hydrogen chloride
- D phosphorus(V) chloride

(Total for Question 6 = 1 mark)

7 Which of these changes has the largest **increase** in the entropy of the system?

- A $\text{H}_2\text{O}(s) \rightarrow \text{H}_2\text{O}(l)$
- B $\text{Hg}(l) \rightarrow \text{Hg}(g)$
- C $\text{H}_2\text{O}(l) + \text{HCl}(g) \rightarrow \text{H}_3\text{O}^+(\text{aq}) + \text{Cl}^-(\text{aq})$
- D $\text{C}(\text{graphite}) \rightarrow \text{C}(\text{diamond})$

(Total for Question 7 = 1 mark)

8 Equal amounts of W and X are mixed and allowed to reach equilibrium.

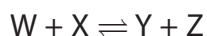

The value of the equilibrium constant is $K_c = 4.85$. At equilibrium, the mixture will contain

- A almost all Y and Z
- B almost all W and X
- C W, X, Y and Z but there is less Y and Z than W and X
- D W, X, Y and Z but there is more Y and Z than W and X

(Total for Question 8 = 1 mark)

Use this space for any rough working. Anything you write in this space will gain no credit.

DO NOT WRITE IN THIS AREA

DO NOT WRITE IN THIS AREA

DO NOT WRITE IN THIS AREA



9 What does **X** represent on the diagram?

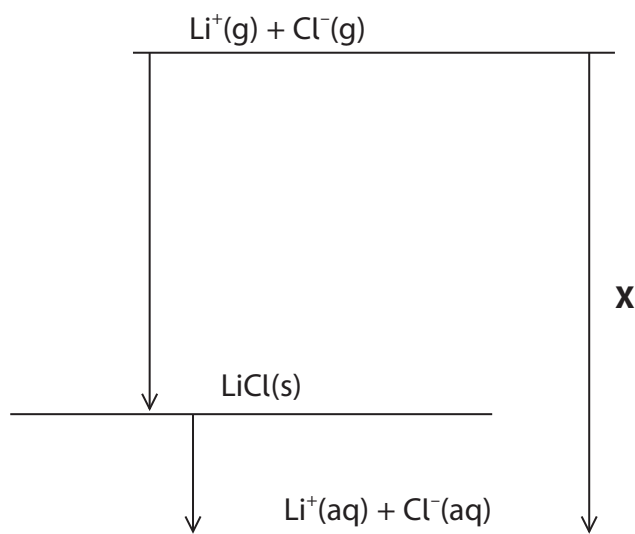

- A sum of enthalpy changes of hydration of the gaseous ions
- B enthalpy change of formation of LiCl
- C enthalpy change of solution of LiCl
- D lattice energy of LiCl

(Total for Question 9 = 1 mark)

10 How are 20 cm^3 of $0.05 \text{ mol dm}^{-3} \text{ H}_2\text{SO}_4(\text{aq})$ and 20 cm^3 of $0.10 \text{ mol dm}^{-3} \text{ CH}_3\text{COOH}(\text{aq})$ alike?

Both solutions

- A have the same pH
- B have the same total concentration of ions
- C have the same total concentration of **negative** ions
- D require 20 cm^3 of $0.10 \text{ mol dm}^{-3} \text{ NaOH}(\text{aq})$ for complete reaction

(Total for Question 10 = 1 mark)

Use this space for any rough working. Anything you write in this space will gain no credit.



11 Which two solutions, both of concentration 0.10 mol dm^{-3} , have been used to produce this titration curve?

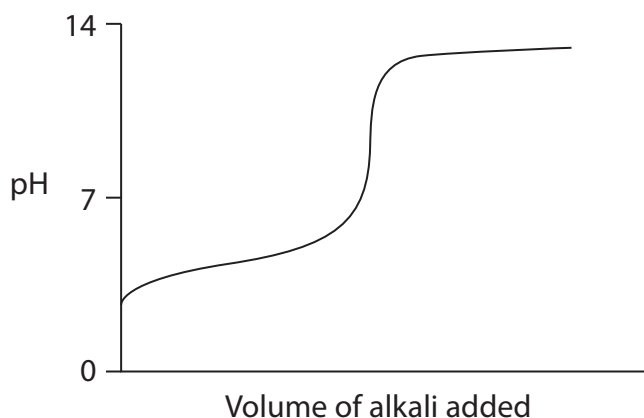

- A HCl(aq) and KOH(aq)
- B HCOOH(aq) and KOH(aq)
- C HCl(aq) and NH₃(aq)
- D HCOOH(aq) and NH₃(aq)

(Total for Question 11 = 1 mark)

12 A solution of sodium hydroxide of concentration $0.0080 \text{ mol dm}^{-3}$ has a pH

- A between 7 and 9
- B between 9 and 11
- C between 11 and 13
- D above 13

(Total for Question 12 = 1 mark)

Use this space for any rough working. Anything you write in this space will gain no credit.

DO NOT WRITE IN THIS AREA

DO NOT WRITE IN THIS AREA

DO NOT WRITE IN THIS AREA



- 13 A student carried out an experiment to determine the equilibrium constant for the reaction to form ethyl ethanoate from ethanol and ethanoic acid.

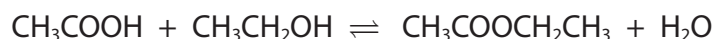

Different amounts of each substance were added to conical flasks, each containing 2.0 cm^3 of 1.0 mol dm^{-3} hydrochloric acid.

Conical flask	Volume added / cm^3				
	HCl (aq)	H_2O (l)	CH_3COOH (l)	$\text{CH}_3\text{COOCH}_2\text{CH}_3$ (l)	$\text{CH}_3\text{CH}_2\text{OH}$ (l)
1	2.0	1.0	0	2.0	0
2	2.0	0	5.0	0	5.0
3	2.0	0	4.0	0	3.0
4	2.0	0	0	3.0	0

The flasks were then stoppered and left for a week to reach equilibrium.

Each mixture was then titrated with 1.0 mol dm^{-3} sodium hydroxide.

- (a) In which flask(s) was the equilibrium approached from the right-hand side of the equation?

(1)

- A flask 1 only
- B flask 4 only
- C flasks 1 and 4 only
- D flasks 2 and 3 only

- (b) Which of these statements explains why it is possible to titrate the reaction mixture directly to find the equilibrium concentrations?

(1)

- A the equilibrium reaction is slow
- B the sodium hydroxide quickly hydrolyses the ester
- C all the reactant concentrations remain constant during the titration
- D a buffer solution forms in the reaction

(Total for Question 13 = 2 marks)



14 A reactant Q is converted into two products. Which of these graphs shows that this reaction is first order with respect to Q?

Graph 1

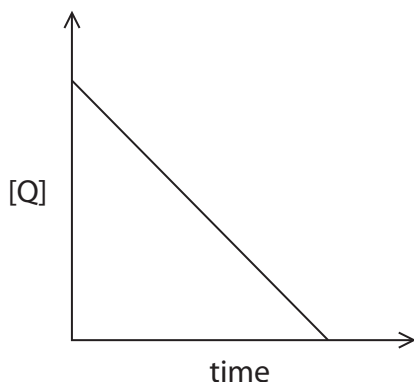

Graph 2

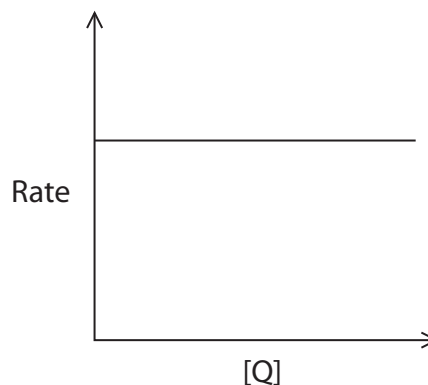

Graph 3

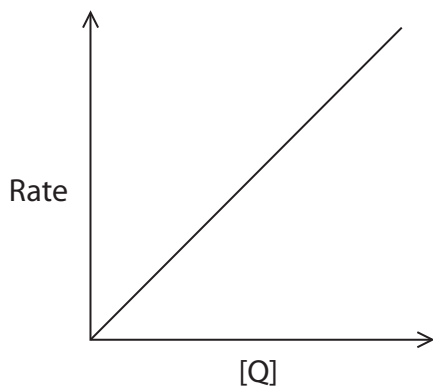

Graph 4

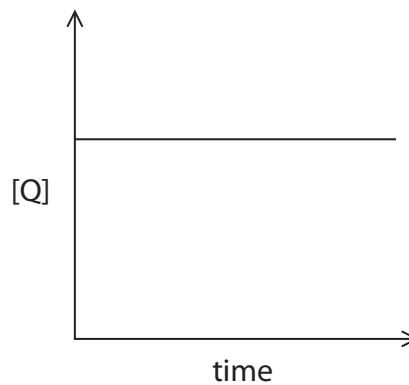

- A Graph 1
- B Graph 2
- C Graph 3
- D Graph 4

(Total for Question 14 = 1 mark)

Use this space for any rough working. Anything you write in this space will gain no credit.

DO NOT WRITE IN THIS AREA

DO NOT WRITE IN THIS AREA

DO NOT WRITE IN THIS AREA



15 This question is about the kinetics of the reaction between nitrogen monoxide and oxygen.

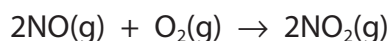

The rate equation for the reaction is $\text{rate} = k[\text{NO}]^2[\text{O}_2]$

(a) Which statement is **not** correct?

(1)

- A the reaction is third order overall
- B the units of the rate of the reaction are $\text{mol dm}^{-3} \text{s}^{-1}$
- C the rate of the reaction increases when the pressure is increased
- D when the concentration of nitrogen monoxide doubles and the concentration of oxygen quadruples, the rate increases by a factor of 8

(b) What are the units of the rate constant, k , for this reaction?

(1)

- A $\text{dm}^9 \text{mol}^{-3} \text{s}^{-1}$
- B $\text{mol}^3 \text{dm}^{-9} \text{s}^{-1}$
- C $\text{mol}^2 \text{dm}^{-6} \text{s}^{-1}$
- D $\text{dm}^6 \text{mol}^{-2} \text{s}^{-1}$

(c) An experiment was carried out using $1.10 \times 10^{-2} \text{ mol dm}^{-3}$ of oxygen and some nitrogen monoxide.

The numerical value of the initial rate and rate constant were:

- initial rate = 3.20×10^{-3}
- rate constant, $k = 1.70 \times 10^3$

What was the initial concentration, in mol dm^{-3} , of the nitrogen monoxide used in the experiment?

(1)

- A 1.31×10^{-2}
- B 1.71×10^{-4}
- C 2.02×10^{-3}
- D 4.50×10^{-2}

(Total for Question 15 = 3 marks)

TOTAL FOR SECTION A = 20 MARKS



SECTION B

Answer ALL the questions.

Write your answers in the spaces provided.

- 16 The compound ethyl 3-oxobutanoate, which is used in food flavouring, has the formula $\text{CH}_3\text{COCH}_2\text{COOCH}_2\text{CH}_3$.

The high resolution proton (^1H) NMR spectrum of this compound is

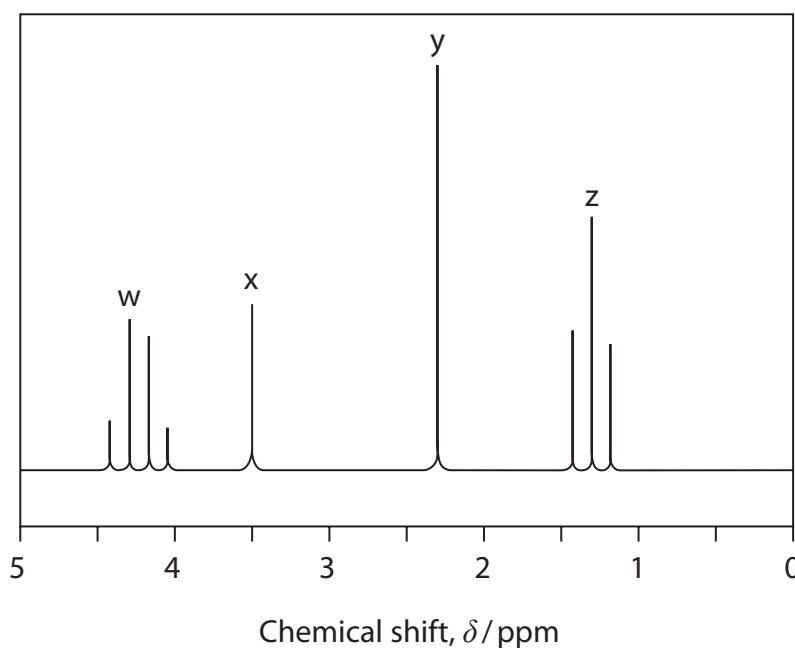

- (a) (i) Identify which groups of hydrogen atoms are responsible for each peak in the spectrum by adding the labels w, x, y and z to the appropriate parts of this displayed formula to match the letters on the spectrum.

(2)

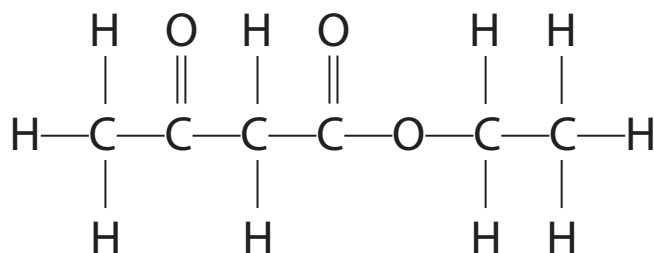

DO NOT WRITE IN THIS AREA

DO NOT WRITE IN THIS AREA

DO NOT WRITE IN THIS AREA



(ii) Explain the splitting patterns of the peaks at 4.2 ppm and 1.3 ppm.

(2)

.....

.....

.....

.....

.....

(iii) The carbon-13 (^{13}C) NMR spectrum of ethyl 3-oxobutanoate has six peaks.

Draw the structure of an **isomer** of ethyl 3-oxobutanoate that contains a carboxylic acid group and a ketone functional group, but only has four peaks in its carbon-13 NMR spectrum.

(1)

DO NOT WRITE IN THIS AREA

DO NOT WRITE IN THIS AREA

DO NOT WRITE IN THIS AREA



(b) A chemist synthesising ethyl 3-oxobutanoate looked for its presence in the reaction mixture using thin-layer chromatography. The solvent used was a mixture of ethoxyethane, $C_2H_5OC_2H_5$, which is polar, and hexane. Under these conditions, the R_f value for ethyl 3-oxobutanoate was 0.45.

(i) Complete the diagram below, showing a chromatogram for ethyl 3-oxobutanoate, including appropriate labels. (3)

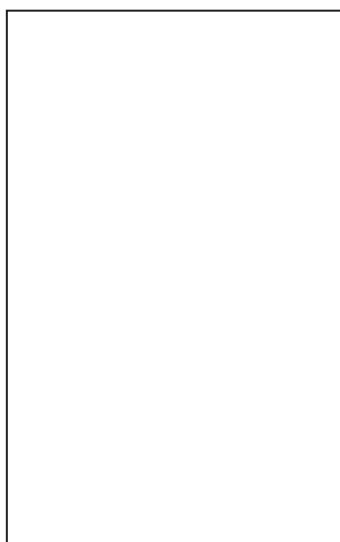

(ii) Suggest why the R_f value for ethyl 3-oxobutanoate is significantly lower than 0.45 when just hexane is used as the solvent. (2)

.....

.....

.....

.....

.....

.....

.....

(Total for Question 16 = 10 marks)



DO NOT WRITE IN THIS AREA

DO NOT WRITE IN THIS AREA

DO NOT WRITE IN THIS AREA

BLANK PAGE



P 6 0 4 7 2 A 0 1 5 3 2

DO NOT WRITE IN THIS AREA

DO NOT WRITE IN THIS AREA

DO NOT WRITE IN THIS AREA

Area with horizontal dotted lines for writing.

(Total for Question 17 = 6 marks)



P 6 0 4 7 2 A 0 1 7 3 2

- 18 The rate constant for the reaction to convert cyclopropane to propene was determined at five different temperatures.

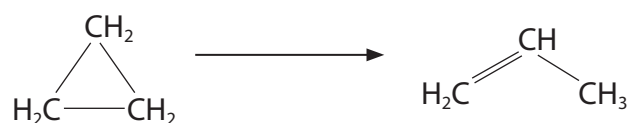

The results are shown in the table.

Temperature (T) / K	1 / Temperature ($1/T$) / K^{-1}	Rate constant (k) / s^{-1}	$\ln k$
719	1.39×10^{-3}	2.49×10^{-5}	-10.60
746	1.34×10^{-3}	1.23×10^{-4}	-9.00
791	1.26×10^{-3}	1.66×10^{-3}	
840		1.83×10^{-2}	-4.00
889	1.12×10^{-3}	1.65×10^{-1}	-1.80

- (a) (i) Complete the table.

(1)

- (ii) Plot a graph of $\ln k$ against $1/T$.

(3)

DO NOT WRITE IN THIS AREA

DO NOT WRITE IN THIS AREA

DO NOT WRITE IN THIS AREA



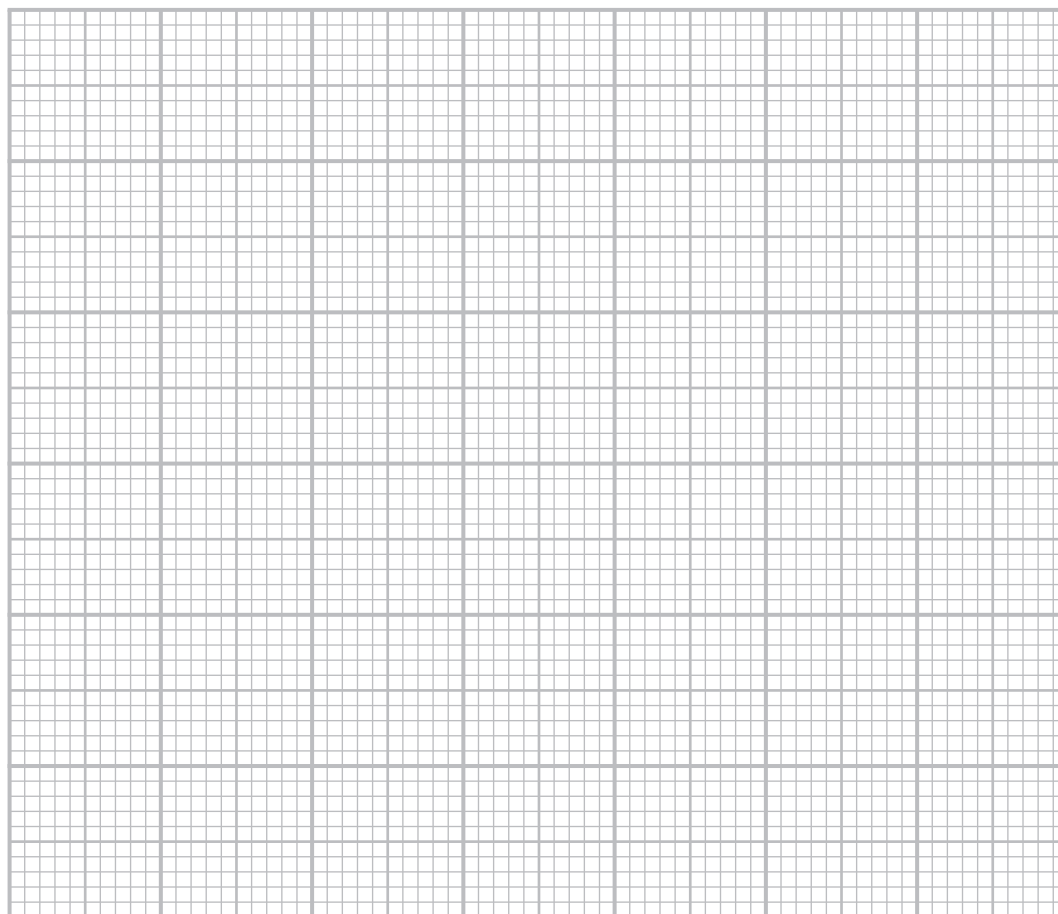

(iii) Use your graph to determine the activation energy, E_a , in kJ mol^{-1} .

You should include the value and units of the gradient of the line.

The Arrhenius equation is

$$\ln k = -\frac{E_a}{R} \times \frac{1}{T} + \text{constant}$$

(3)

DO NOT WRITE IN THIS AREA

DO NOT WRITE IN THIS AREA

DO NOT WRITE IN THIS AREA



DO NOT WRITE IN THIS AREA

DO NOT WRITE IN THIS AREA

DO NOT WRITE IN THIS AREA

(b) The activation energy for many reactions is around $+50 \text{ kJ mol}^{-1}$.

Given this information, comment on your value for E_a .

(2)

.....

.....

.....

.....

.....

.....

(c) Explain the trend in the value of the rate constant k as the temperature increases.

(3)

.....

.....

.....

.....

.....

.....

.....

.....

.....

.....

(Total for Question 18 = 12 marks)



DO NOT WRITE IN THIS AREA

DO NOT WRITE IN THIS AREA

DO NOT WRITE IN THIS AREA

BLANK PAGE



P 6 0 4 7 2 A 0 2 1 3 2

19 This question is about halides.

- (a) Silicon tetrachloride, SiCl_4 , is used in the manufacture of optical fibres. It can be made by the reaction of silicon carbide, SiC , with hydrogen chloride using a catalyst of nickel(II) chloride.

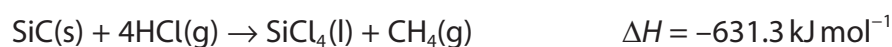

The standard molar entropies S^\ominus , of the substances are shown in the table.

Substance	SiC(s)	HCl(g)	$\text{SiCl}_4\text{(l)}$	$\text{CH}_4\text{(g)}$
$S^\ominus / \text{JK}^{-1} \text{ mol}^{-1}$	+16.5	+186.8	+239.7	+186.2

- (i) Calculate the total entropy change, ΔS_{total} , for this reaction, at 298 K, using the information given.

Include a sign and units in your answer which should be given to an appropriate number of significant figures.

(5)

DO NOT WRITE IN THIS AREA

DO NOT WRITE IN THIS AREA

DO NOT WRITE IN THIS AREA



(ii) In industry, the reaction is carried out at 700 °C.

By considering entropy and other relevant factors, justify the use of this temperature. (3)

.....

.....

.....

.....

.....

.....

.....

.....

(iii) Use your answer from (a)(i) to calculate the equilibrium constant for the reaction at 298 K. (2)

DO NOT WRITE IN THIS AREA

DO NOT WRITE IN THIS AREA

DO NOT WRITE IN THIS AREA



(b) The following data can be used in a Born-Haber cycle for calcium iodide, CaI₂.

Letter	Energy change	Value / kJ mol ⁻¹
A	Enthalpy change of atomisation of calcium	+178.2
B	First ionisation energy of calcium	+590
C	Second ionisation energy of calcium	+1145
D	Enthalpy change of atomisation of iodine (½I ₂ (s) → I(g))	+106.8
E	Electron affinity of iodine	-295.4
F	Lattice energy of calcium iodide	-2074

(i) Complete the Born-Haber cycle by adding letters in the boxes for the energy changes, relevant species on the blank lines and arrowheads to show the direction of each energy change.

(3)

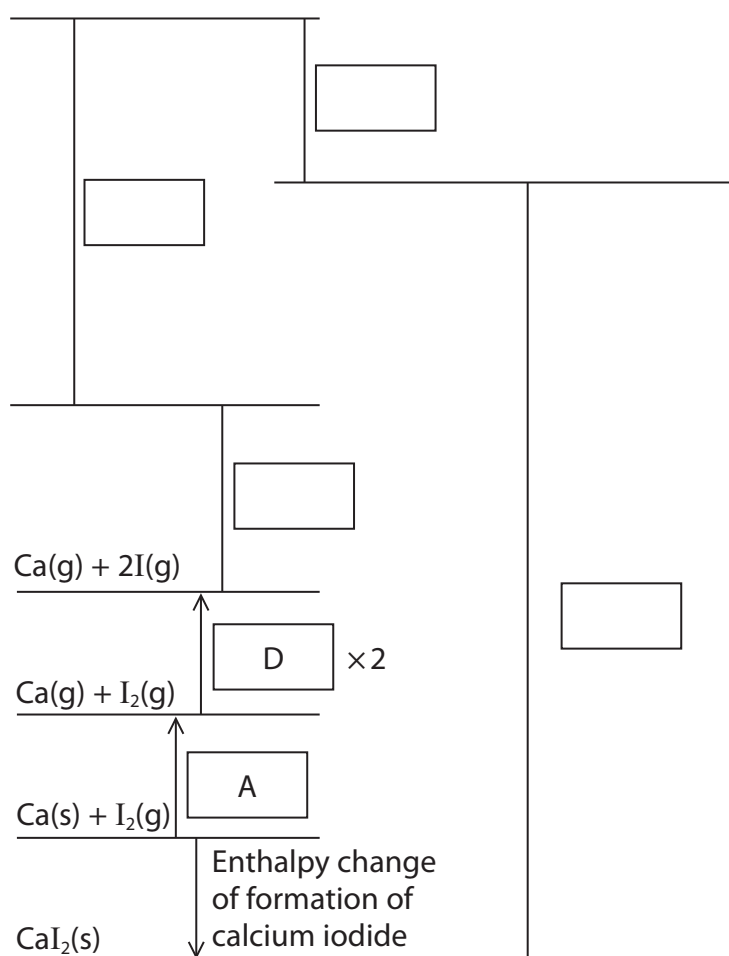

(ii) Use the data to calculate the value for the enthalpy change of formation of calcium iodide.

(2)

(iii) The value for the lattice energy of calcium iodide determined experimentally by using the Born-Haber cycle differs significantly from the theoretical calculated value.

Explain why the Born-Haber and the theoretical values for the lattice energies are similar for calcium fluoride but significantly different for calcium iodide.

(4)

.....

.....

.....

.....

.....

.....

.....

.....

.....

DO NOT WRITE IN THIS AREA

DO NOT WRITE IN THIS AREA

DO NOT WRITE IN THIS AREA



(c) The electron affinity of iodine is $-295.4 \text{ kJ mol}^{-1}$.

Explain how the electron affinity of chlorine differs from that of iodine.

(3)

.....

.....

.....

.....

.....

.....

.....

.....

.....

.....

(Total for Question 19 = 22 marks)

TOTAL FOR SECTION B = 50 MARKS

DO NOT WRITE IN THIS AREA

DO NOT WRITE IN THIS AREA

DO NOT WRITE IN THIS AREA



SECTION C

Answer ALL the questions.

Write your answers in the spaces provided.

20 This question is about ethanoic acid and some of its compounds.

- (a) Three students, A, B and C, carried out an investigation to determine the amount of isoamyl acetate, an ester of ethanoic acid, in a banana food flavouring.

They hydrolysed the ester with excess sodium hydroxide solution.

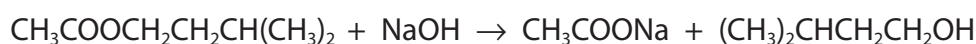

The amount of sodium hydroxide remaining was determined by titrating the reaction mixture with hydrochloric acid.

- (i) Give the systematic name for isoamyl acetate.

(1)

- (ii) 6.06×10^{-3} mol of sodium hydroxide reacted with the ester present in 1.07 g of the flavouring.

Calculate the percentage by mass of the ester in the food flavouring.

(3)

DO NOT WRITE IN THIS AREA

DO NOT WRITE IN THIS AREA

DO NOT WRITE IN THIS AREA



(iii) The students used 25.0 cm^3 of sodium hydroxide solution with concentration $0.980 \text{ mol dm}^{-3}$ for the hydrolysis.

Calculate the pH of the reaction mixture when the hydrolysis is complete.
Assume the total volume is 25.0 cm^3 .

[Ionic product of water, $K_w = 1.0 \times 10^{-14} \text{ mol}^2 \text{ dm}^{-6}$] (3)

(iv) Two indicators, methyl orange and phenolphthalein, were available for this titration.

Student A thought only methyl orange could be used.
Student B thought only phenolphthalein could be used.
Student C suggested either indicator could be used.

Explain which student is correct. (2)

.....

.....

.....

.....

.....

.....

.....

.....

.....

.....

.....

DO NOT WRITE IN THIS AREA

DO NOT WRITE IN THIS AREA

DO NOT WRITE IN THIS AREA



(v) Describe how the sodium ethanoate in the final reaction mixture could be converted into ethanoic acid.

(1)

.....

.....

.....

DO NOT WRITE IN THIS AREA

DO NOT WRITE IN THIS AREA

DO NOT WRITE IN THIS AREA



DO NOT WRITE IN THIS AREA

DO NOT WRITE IN THIS AREA

DO NOT WRITE IN THIS AREA

(b) Ethanoic acid can be used to form buffer solutions.

- (i) Calculate the pH of the buffer solution formed when 50.0 cm^3 of ethanoic acid with concentration of $0.150 \text{ mol dm}^{-3}$ is mixed with 30.0 cm^3 of sodium hydroxide solution with concentration of $0.142 \text{ mol dm}^{-3}$.

$$[K_a \text{ for ethanoic acid} = 1.70 \times 10^{-5} \text{ mol dm}^{-3}]$$

(5)



