

Write your name here

Surname

Other names

**Pearson Edexcel**  
**International**  
**Advanced Level**

Centre Number

|  |  |  |  |  |  |
|--|--|--|--|--|--|
|  |  |  |  |  |  |
|--|--|--|--|--|--|

Candidate Number

|  |  |  |  |  |  |
|--|--|--|--|--|--|
|  |  |  |  |  |  |
|--|--|--|--|--|--|

# Physics

**International Advanced Subsidiary/Advanced Level**  
**Unit 2: Waves and Electricity**

Sample Assessment Materials for first teaching September 2018

**Time: 1 hour 30 minutes**

Paper Reference

**WPH12/01****You must have:**

Scientific calculator, Ruler

Total Marks

## Instructions

- Use **black** ink or **black** ball-point pen.
- **Fill in the boxes** at the top of this page with your name, centre number and candidate number.
- Answer **all** questions.
- Answer the questions in the spaces provided – *there may be more space than you need.*
- **Show all your working out in calculations and include units where appropriate.**

## Information

- The total mark for this paper is 80.
- The marks for **each** question are shown in brackets – *use this as a guide as to how much time to spend on each question.*
- In questions marked with an **asterisk** (\*), marks will be awarded for your ability to structure your answer logically, showing how the points that you make are related or follow on from each other where appropriate.

## Advice

- Read each question carefully before you start to answer it.
- Try to answer every question.
- Check your answers if you have time at the end.

Turn over ►

S58681A

©2018 Pearson Education Ltd.

1/1/1/1/



Pearson

## SECTION A

Answer ALL questions.

For questions 1–10 select one answer from A to D and put a cross in the box ☒.  
If you change your mind, put a line through the box ~~☒~~ and then  
mark your new answer with a cross ☒.

1 Which of the following is a unit for frequency?

- A s
- B  $\text{m}^{-1}$
- C  $\text{s}^{-1}$
- D  $\text{m s}^{-1}$

(Total for Question 1 = 1 mark)

2 Which of the following properties is **not** shown by longitudinal waves?

- A diffraction
- B interference
- C polarisation
- D refraction

(Total for Question 2 = 1 mark)

DO NOT WRITE IN THIS AREA

DO NOT WRITE IN THIS AREA

DO NOT WRITE IN THIS AREA

- 3 The diagram represents the position of particles before a progressive wave passes and at a particular instant as the wave passes.

X ..... before wave passes

X ..... as wave passes

Which of the following graphs correctly shows the variation of pressure with distance from X as the wave passes at the instant shown?

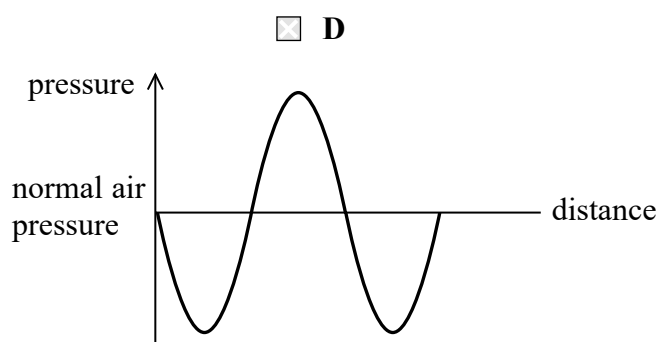
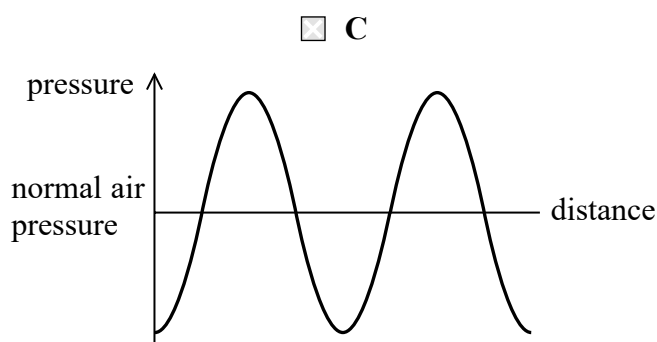
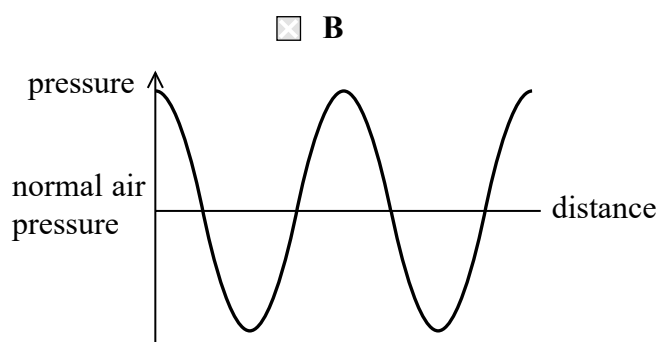
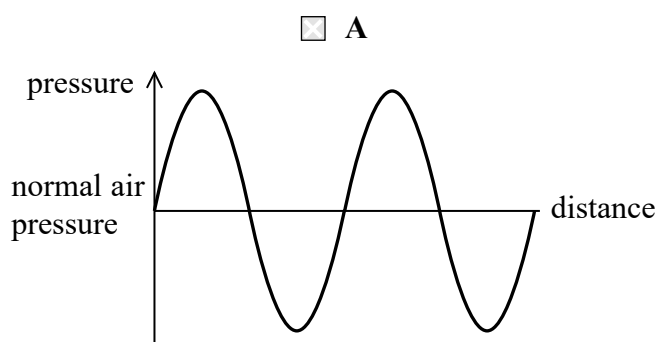

(Total for Question 3 = 1 mark)

- 4 A Slinky spring is stretched a total length  $l$  from one side of a classroom to the other. The tension in the spring is  $T$ . A wave pulse travels along the spring with a velocity  $v$ . The spring is taken to a sports hall and stretched to a total length  $2l$  with tension  $2T$ .

Which of the following gives the velocity of the wave pulse along the spring in the sports hall?

- A  $\frac{v}{\sqrt{2}}$
- B  $v$
- C  $\sqrt{2}v$
- D  $2v$

(Total for Question 4 = 1 mark)

- 5 There is a potential difference of 6 V across a  $4\ \Omega$  resistor. A charge of 5 C flows through the resistor.

Which of the following is the energy transferred by the resistor?

- A 7.5 J  
 B 20 J  
 C 24 J  
 D 30 J

(Total for Question 5 = 1 mark)

- 6 Which of the following will have the largest de Broglie wavelength?

- A An electron moving at almost the speed of light.  
 B A proton moving at half the speed of light.  
 C A tennis ball just after being hit by a tennis racket.  
 D An athlete running a one hundred metre race.

(Total for Question 6 = 1 mark)

- 7 The formulae sheet contains the formula

$$I = nqvA$$

where  $I$  is the current through a sample of a material.

Which two quantities in the formula are related to the resistivity of the material?

- A  $n$  and  $A$   
 B  $q$  and  $v$   
 C  $n$  and  $v$   
 D  $q$  and  $A$

(Total for Question 7 = 1 mark)

DO NOT WRITE IN THIS AREA

DO NOT WRITE IN THIS AREA

DO NOT WRITE IN THIS AREA

- 8 Which graph correctly shows how the potential difference  $V$  varies with the current  $I$  for a filament bulb?

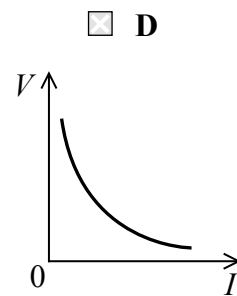
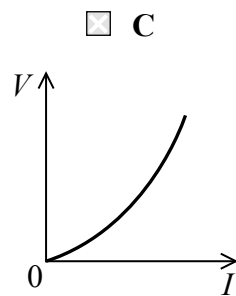
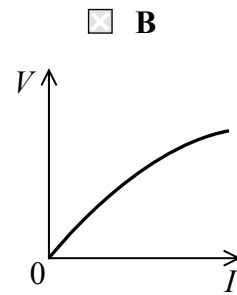
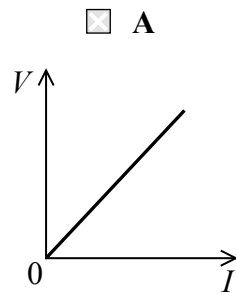

(Total for Question 8 = 1 mark)

- 9 Huygen's construction can be used to explain what happens to a wave when it meets an obstacle.

Which diagram is a correct attempt to use Huygen's construction to predict the position of the next wavefront?

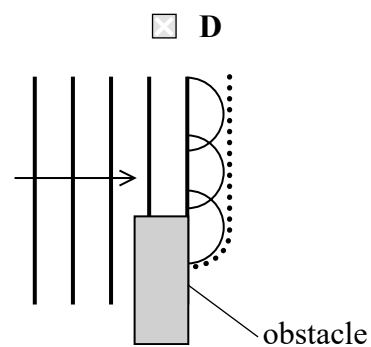
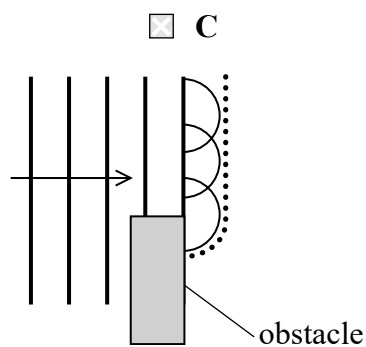
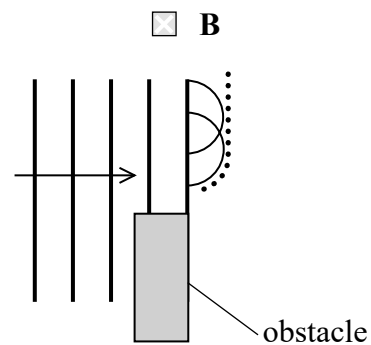
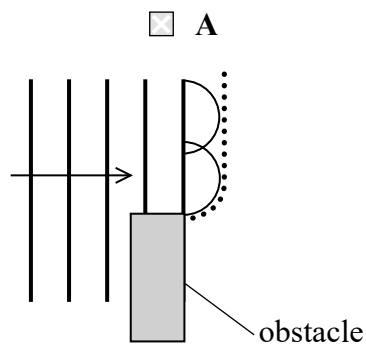

(Total for Question 9 = 1 mark)

- 10 Laser light of wavelength  $650 \times 10^{-9}$  m is directed at a diffraction lines grating.  
The grating has 50 lines per mm.

A diffraction pattern appears on a screen that is 4 m from the grating.

Which expression gives the angle, in radians, between the zero order and first order fringes?

- A  $650 \times 10^{-9} \times 50$
- B  $650 \times 10^{-6} \times 50$
- C  $\sin^{-1}\left(\frac{650 \times 10^{-9}}{4}\right)$
- D  $\sin^{-1}\left(\frac{650 \times 10^{-6}}{4}\right)$

(Total for Question 10 = 1 mark)

---

**TOTAL FOR SECTION A = 10 MARKS**

DO NOT WRITE IN THIS AREA

DO NOT WRITE IN THIS AREA

DO NOT WRITE IN THIS AREA

**SECTION B**

**Answer ALL questions.**

**11** An airport uses the pulse-echo technique with radio waves to monitor the positions of aeroplanes. These radio waves have a wavelength of about 0.1 m.

(a) State what is meant by wavelength.

(1)

.....

.....

(b) Determine whether a pulse of duration  $1.5\mu\text{s}$  would be suitable to monitor the position of an aeroplane at a distance of 60 km from the airport.

(3)

.....

.....

.....

.....

.....

DO NOT WRITE IN THIS AREA

DO NOT WRITE IN THIS AREA

DO NOT WRITE IN THIS AREA

- (c) The radio waves are emitted by a source at position X. The radio waves are reflected towards the aeroplane by a parabolic reflector that produces a beam as shown.

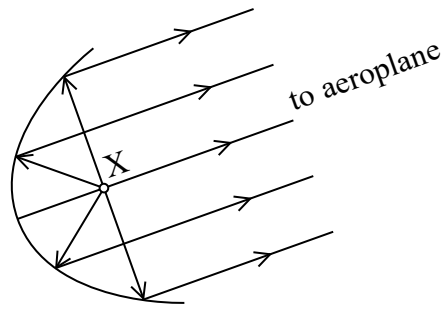

Calculate the power of the radio waves emitted by the source.

intensity of beam of radio waves =  $0.16 \text{ kW m}^{-2}$

cross-sectional area of beam =  $13.2 \text{ m}^2$

(2)

Power = .....

**(Total for Question 11 = 6 marks)**

DO NOT WRITE IN THIS AREA

DO NOT WRITE IN THIS AREA

DO NOT WRITE IN THIS AREA



DO NOT WRITE IN THIS AREA

DO NOT WRITE IN THIS AREA

DO NOT WRITE IN THIS AREA

\*12 A spectrum can be produced by light from the Sun.



www.scinatech.com

Discuss why black lines appear on this spectrum.

(6)

Area for student response with horizontal dotted lines.

**(Total for Question 12 = 6 marks)**

- 13 A teacher demonstrated standing waves using the apparatus below. The height of the reservoir can be adjusted to vary the length of the air column in the glass tube.

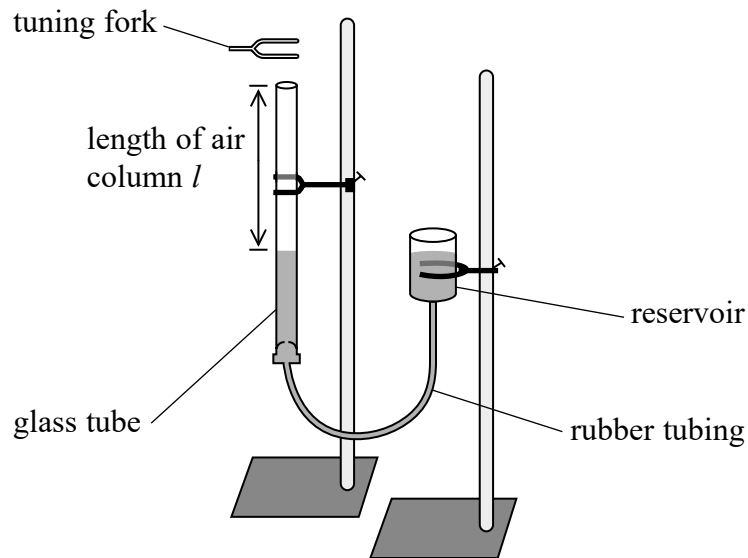

The teacher tapped a tuning fork on a table and placed it above the glass tube. He increased the length of the air column from zero until a sound was heard. At this moment a standing wave was formed in the air column, producing a sound with the same frequency as the tuning fork.

When a sound is heard, there is always a node produced at the surface of the water and an antinode at the top of the air column.

The teacher repeated this with tuning forks of different frequency  $f$  and recorded the corresponding lengths  $l$ .

- (a) State what is meant by a standing wave.

(1)

.....

.....

.....

(b) The teacher plotted a graph of  $f$  against  $\frac{1}{l}$ .

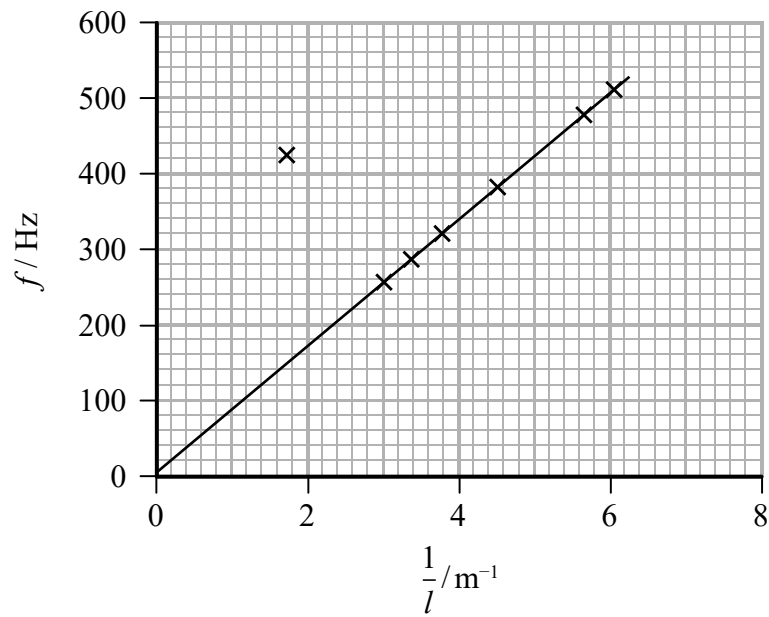

(i) Explain why the speed of sound in air is equal to  $4 \times$  the gradient of this graph.

(3)

(ii) Show that the speed of sound in air is about  $300 \text{ m s}^{-1}$ .

(2)

- (iii) The teacher says that, for a tuning fork of a particular frequency, sounds will be heard for different lengths of the air column.

One point plotted on the graph does not lie on the line of best fit.

Deduce whether this point is an anomaly or whether it corresponds to an audible sound.

(3)

.....

.....

.....

.....

.....

.....

.....

**(Total for Question 13 = 9 marks)**

DO NOT WRITE IN THIS AREA

DO NOT WRITE IN THIS AREA

DO NOT WRITE IN THIS AREA

14 A light dependent resistor (LDR) has a resistance of  $6100\ \Omega$  when illuminated with indoor lighting.

- (a) Explain how the resistance of an LDR changes with illumination. Your answer should include reference to conduction electrons.

(2)

.....

.....

.....

.....

.....

- (b) A student made an electrical cell using a lemon, a piece of zinc and a piece of copper as shown.

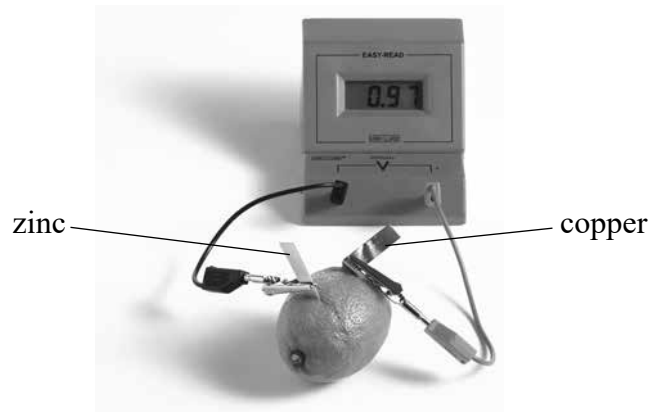

© Science Photo Library

The student connected a digital voltmeter to the cell and recorded an electromotive force (e.m.f.) of  $0.97\text{ V}$ .

She then connected the LDR to the cell and recorded a reading from the digital voltmeter of  $0.47\text{ V}$ .

- (i) Define e.m.f.

(1)

.....

.....

(ii) Calculate the internal resistance of the cell.

resistance of LDR =  $6100\ \Omega$

(3)

Internal resistance = .....

(iii) Calculate the power transferred by the LDR.

(2)

Power transferred = .....

**(Total for Question 14 = 8 marks)**

DO NOT WRITE IN THIS AREA

DO NOT WRITE IN THIS AREA

DO NOT WRITE IN THIS AREA

15 Some observatories are looking for evidence of planets orbiting stars.

Detecting a planet is difficult because its reflected light is insignificant compared to the light emitted by the star.

A technique known as “nulling interferometry” is being developed. It relies on the property of interference produced by the superposition of two beams of coherent light.

(a) Beams of light from the star and from the planet are collected by telescopes  $T_1$  and  $T_2$ . The beams are superimposed using a beam combiner as shown.

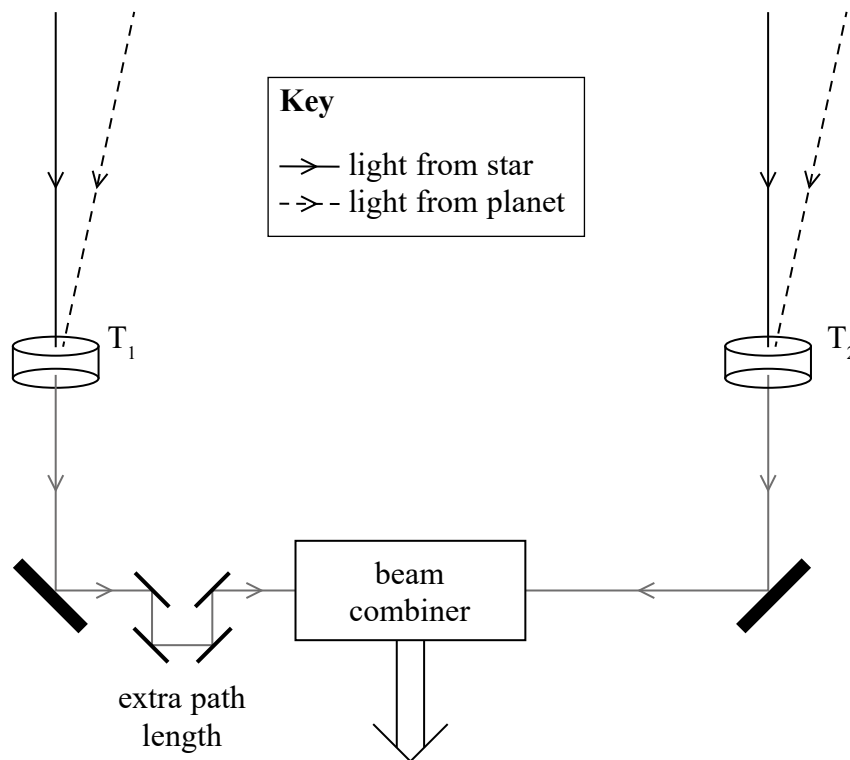

Light from the star would arrive at both telescopes having travelled equal distances. A system of mirrors is used to increase the path length of one of the beams by an extra path length, equal to half the wavelength of the light.

(i) Explain what happens when the two beams of light from the star are combined.

(2)

.....

.....

.....

.....

.....

(ii) The two beams of light from the planet arrive at the telescopes at a slight angle so these beams have travelled different distances. Explain the condition that would result in this light combining to reveal the planet.

(2)

.....

.....

.....

.....

(b) At present, nulling interferometry has been demonstrated in laboratories using infrared radiation.

Explain why it will be more difficult to demonstrate the effect with visible light from stars.

(2)

.....

.....

.....

.....

.....

**(Total for Question 15 = 6 marks)**

DO NOT WRITE IN THIS AREA

DO NOT WRITE IN THIS AREA

DO NOT WRITE IN THIS AREA



DO NOT WRITE IN THIS AREA

DO NOT WRITE IN THIS AREA

DO NOT WRITE IN THIS AREA

16 Sensors that monitor the moisture in soil can be useful to farmers.

The sensor includes two probes as shown in the photograph. The probes are pushed into the soil.

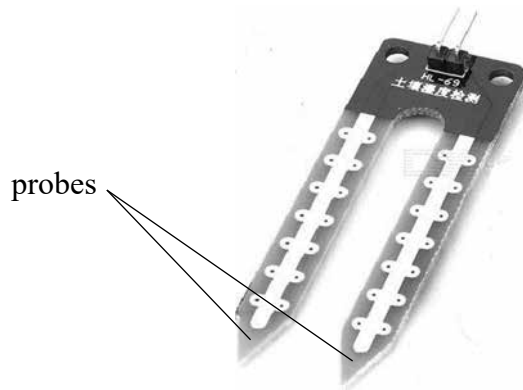

Source from: <http://www.dx.com/p/produino-lm393-3-3-5v-soil-hygrometer-detection-module-soil-moisture-sensor-for-arduino-blue-290154#.WQhcuPkrKUK>

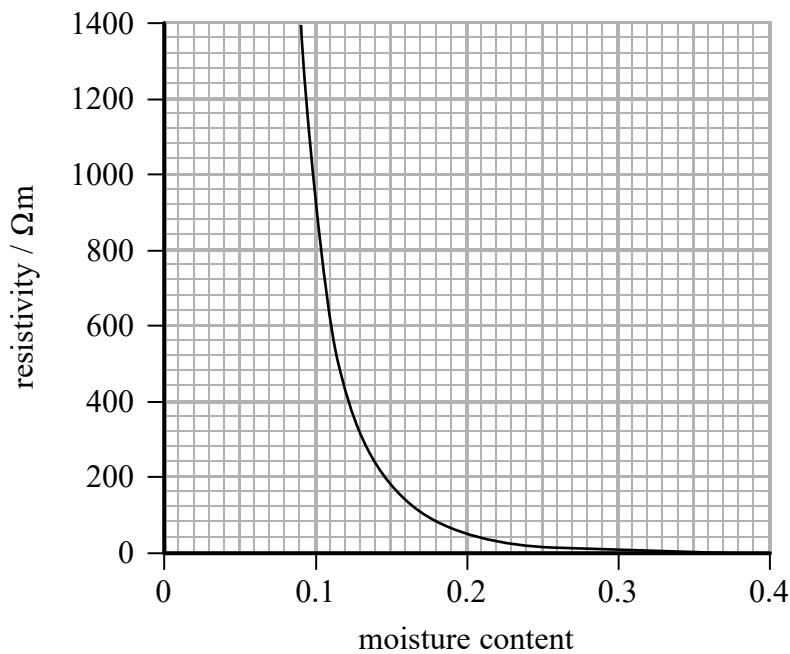

The graph shows how the resistivity of soil varies with moisture content measured as a fraction of the volume of soil.

(a) Show that the resistance of the soil between the two probes is about 21 kΩ when the moisture content is 0.14

length of soil between probes = 5.0 cm

effective cross-sectional area of soil between probes = 5.8 cm<sup>2</sup>

(3)

.....

.....

.....

.....

.....

.....

- (b) The sensor consists of a circuit that includes the probes and provides an output potential difference (p.d.) as shown. The output p.d. can be used to switch on a water supply.

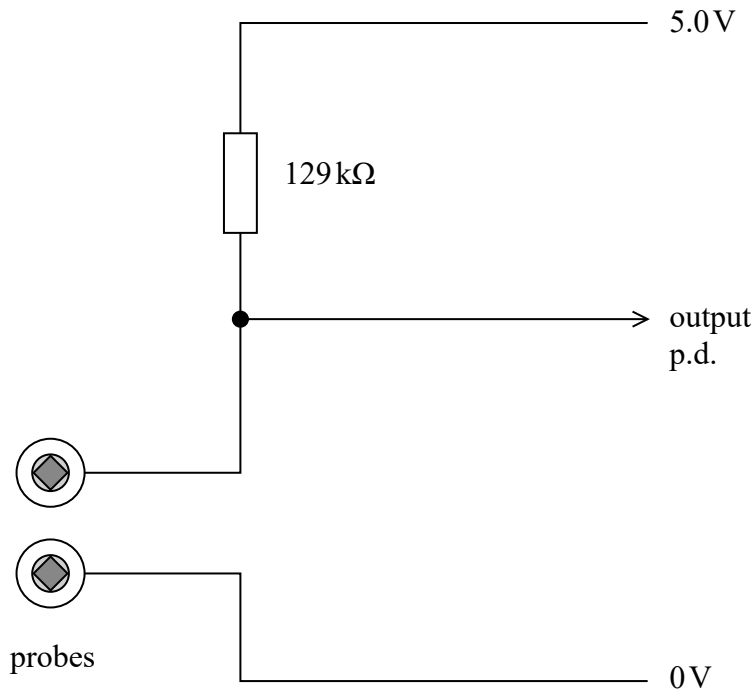

- (i) Calculate the output p.d. when the resistance of the soil between the probes is  $21\text{ k}\Omega$  (2)

Output p.d. = .....

(ii) A farmer finds the following notes about the sensor on the internet.

If the output p.d. falls below 0.7 V then this indicates that the soil has a moisture content of less than 0.14 and the water supply is switched on to make the soil wetter.

Discuss whether this information is correct.

(4)

.....

.....

.....

.....

.....

.....

.....

.....

(c) A different sensor can be produced by replacing the probes with a negative temperature coefficient thermistor.

Explain what this sensor circuit could be used for.

(3)

.....

.....

.....

.....

.....

.....

.....

.....

**(Total for Question 16 = 12 marks)**

DO NOT WRITE IN THIS AREA

DO NOT WRITE IN THIS AREA

DO NOT WRITE IN THIS AREA

17 A gold leaf electroscope is used to detect very small amounts of charge. The diagram shows an uncharged gold leaf electroscope.

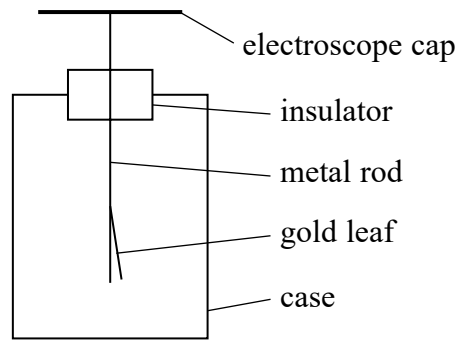

When the electroscope cap is given a negative charge, electrons spread along the metal rod and the gold leaf so they both become negatively charged. The rod and leaf repel each other, so the gold leaf rises up as shown below.

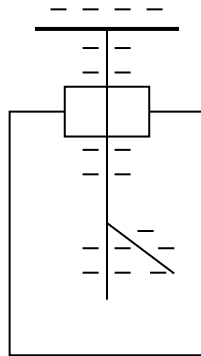

A gold leaf electroscope can be used to demonstrate the photoelectric effect. A clean zinc plate is placed onto the cap of the electroscope and the plate and electroscope are given a negative charge. Ultraviolet radiation is shone onto the zinc plate and the gold leaf slowly falls.

(a) Explain why the gold leaf falls.

(3)

.....

.....

.....

.....

.....

.....

.....

.....

DO NOT WRITE IN THIS AREA

DO NOT WRITE IN THIS AREA

DO NOT WRITE IN THIS AREA

(b) Zinc has a work function of 4.3 eV. Calculate the maximum wavelength of light that will produce the photoelectric effect with zinc.

(3)

DO NOT WRITE IN THIS AREA

.....  
.....  
.....  
.....  
.....  
.....

Maximum wavelength = .....

(c) The electroscope is charged again. The ultraviolet radiation is replaced by a high intensity source of infrared radiation and the demonstration is repeated. The gold leaf does not fall.

Explain why the wave nature of electromagnetic radiation cannot be used to explain this observation.

(3)

DO NOT WRITE IN THIS AREA

.....  
.....  
.....  
.....  
.....  
.....  
.....  
.....

**(Total for Question 17 = 9 marks)**

DO NOT WRITE IN THIS AREA

18 The concentration of sugar in fruit juice can be determined using a refractometer. A simple refractometer consists of a 45° prism made of glass.

(a) Calculate the speed of light in glass.

refractive index of glass = 1.52

(2)

.....  
.....  
.....

Speed of light in glass = .....

(b) The diagram shows the path of a beam of light travelling from a light source in air through a 45° glass prism. The path taken by the beam of light is shaded. The critical angle for glass is 41°.

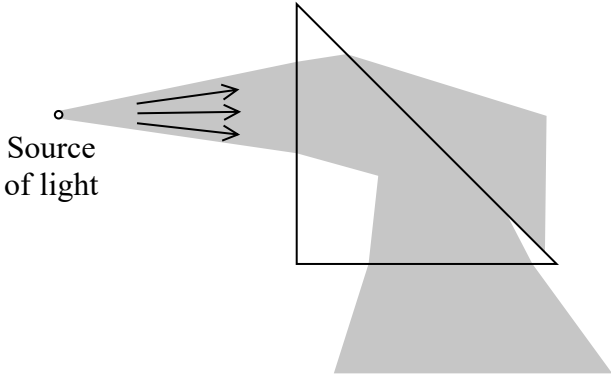

Explain the path of the beam of light.

(4)

.....  
.....  
.....  
.....  
.....  
.....  
.....  
.....  
.....

DO NOT WRITE IN THIS AREA

DO NOT WRITE IN THIS AREA

DO NOT WRITE IN THIS AREA

- (c) A sample of fruit juice is placed on the prism. The initial path of the beam of light is shown. Some of the transmitted light falls onto a scale.

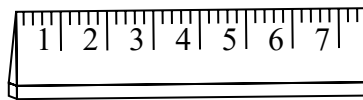
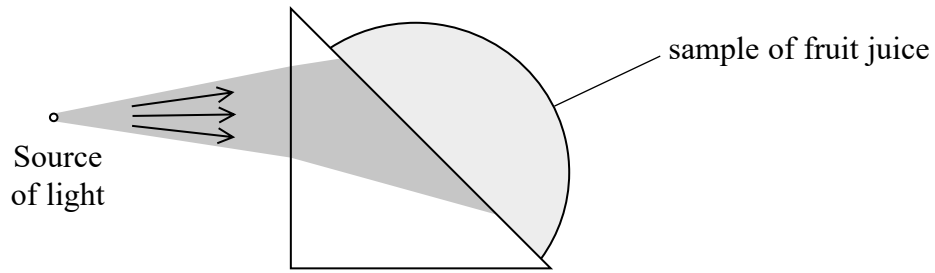

scale

- (i) Show that the critical angle for light passing from the glass to the fruit juice is about  $59^\circ$ .

refractive index of fruit juice = 1.30

(2)

.....

.....

.....

.....

.....

- (ii) Add to the diagram to complete the path of the beam of light.

(3)

DO NOT WRITE IN THIS AREA

DO NOT WRITE IN THIS AREA

DO NOT WRITE IN THIS AREA

(iii) Juice containing a higher concentration of sugar will have a greater refractive index.

Explain how the length of the scale that is illuminated will change if this fruit juice is replaced with a sample containing a higher concentration of sugar.

(3)

.....

.....

.....

.....

.....

.....

.....

**(Total for Question 18 = 14 marks)**

---

**TOTAL FOR SECTION B = 70 MARKS**  
**TOTAL FOR PAPER = 80 MARKS**

DO NOT WRITE IN THIS AREA

DO NOT WRITE IN THIS AREA

DO NOT WRITE IN THIS AREA

Every effort has been made to contact copyright holders to obtain their permission for the use of copyright material. Pearson Education Ltd. will, if notified, be happy to rectify any errors or omissions and include any such rectifications in future editions.