

Write your name here

Surname

Other names

Pearson Edexcel
International
Advanced Level

Centre Number

--	--	--	--	--	--

Candidate Number

--	--	--	--	--

Physics

Advanced

Unit 4: Physics on the Move

Monday 20 June 2016 – Morning

Time: 1 hour 35 minutes

Paper Reference

WPH04/01

You do not need any other materials.

Total Marks

Instructions

- Use **black** ink or ball-point pen.
- **Fill in the boxes** at the top of this page with your name, centre number and candidate number.
- Answer **all** questions.
- Answer the questions in the spaces provided
– *there may be more space than you need.*

Information

- The total mark for this paper is 80.
- The marks for **each** question are shown in brackets
– *use this as a guide as to how much time to spend on each question.*
- Questions labelled with an **asterisk** (*) are ones where the quality of your written communication will be assessed
– *you should take particular care with your spelling, punctuation and grammar, as well as the clarity of expression, on these questions.*
- The list of data, formulae and relationships is printed at the end of this booklet.
- Candidates may use a scientific calculator.

Advice

- Read each question carefully before you start to answer it.
- Keep an eye on the time.
- Try to answer every question.
- Check your answers if you have time at the end.

Turn over ►

P46653A

©2016 Pearson Education Ltd.

1/1/1/1/1/



PEARSON

SECTION A

Answer ALL questions.

For questions 1–10, in Section A, select one answer from A to D and put a cross . If you change your mind, put a line through the box and then mark your new answer with a cross .

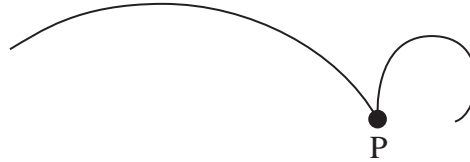
- 1 The diagram shows the tracks from an event at point P in a bubble chamber. There is a uniform magnetic field directed into the page.



Which of the following is the reason why the tracks shown **cannot** represent the production of a proton-antiproton pair with equal kinetic energies?

- A The curvature is perpendicular to the magnetic field.
 B The tracks curve in different directions.
 C The tracks have different curvatures.
 D There is no track before point P.

(Total for Question 1 = 1 mark)

- 2 The table compares the mass and charge of an electron with the mass and charge of a positron.

Select the line in the table that is correct.

	Mass	Type of charge
<input type="checkbox"/> A	equal	same
<input type="checkbox"/> B	equal	opposite
<input type="checkbox"/> C	unequal	same
<input type="checkbox"/> D	unequal	opposite

(Total for Question 2 = 1 mark)

DO NOT WRITE IN THIS AREA

DO NOT WRITE IN THIS AREA

DO NOT WRITE IN THIS AREA



3 Which of the following is a correct statement about uniform electric fields?

- A The field strength is the same at all points.
- B The field strength is the same in all directions.
- C The field produces no force on a stationary charged particle.
- D The force on a charged particle is perpendicular to the field.

(Total for Question 3 = 1 mark)

4 In an electron gun, electrons are released from a heated filament.

What is this process called?

- A excitation
- B ionisation
- C photoelectric emission
- D thermionic emission

(Total for Question 4 = 1 mark)

5 The diagram shows two horizontal parallel plates separated by a distance d . There is a potential difference V across the plates. An oil drop with charge Q is held stationary between the plates.

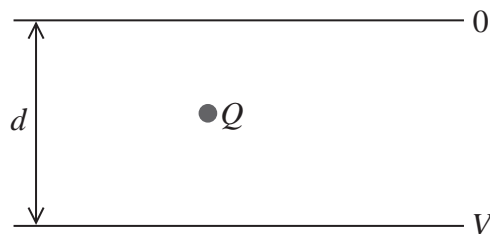

Which of the following gives the mass m of the oil drop?

- A $\frac{dg}{VQ}$
- B $\frac{VQ}{dg}$
- C $\frac{V}{Qdg}$
- D $\frac{Qdg}{V}$

(Total for Question 5 = 1 mark)



6 Which of the following is an equivalent unit to the tesla?

- A N A m
 B N A m^{-1}
 C $\text{N A}^{-1} \text{ m}$
 D $\text{N A}^{-1} \text{ m}^{-1}$

(Total for Question 6 = 1 mark)

7 A magnetic field of flux density $4.0 \times 10^{-3} \text{ T}$ passes through a coil of wire, at an angle of 55° to the plane of the coil. The coil has an area of $2.5 \times 10^{-3} \text{ m}^2$.

Calculate the magnetic flux through the coil.

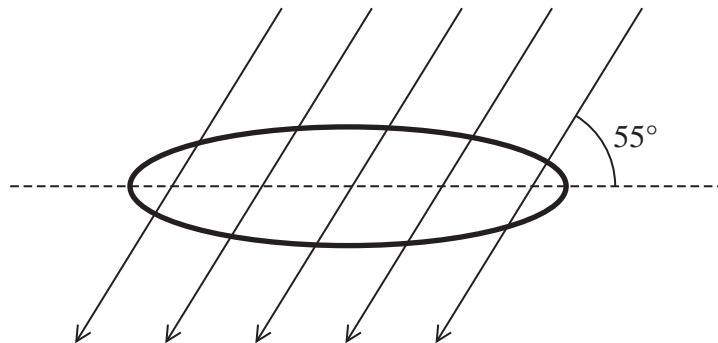

- A $5.7 \times 10^{-6} \text{ Wb}$
 B $8.2 \times 10^{-6} \text{ Wb}$
 C $1.0 \times 10^{-5} \text{ Wb}$
 D $1.4 \times 10^{-5} \text{ Wb}$

(Total for Question 7 = 1 mark)

8 A proton accelerates in an electric field and gains kinetic energy, giving it a change in momentum Δp . An alpha particle accelerates in the same electric field and gains the same kinetic energy.

The magnitude of the change in momentum of the alpha particle is given by

- A $\sqrt{2} \Delta p$
 B $2\Delta p$
 C $\sqrt{8} \Delta p$
 D $4\Delta p$

(Total for Question 8 = 1 mark)



9 A $4.0 \mu\text{F}$ capacitor discharges through a $560 \text{ k}\Omega$ resistor. What is the time constant of the circuit?

- A $2.2 \times 10^{-3} \text{ s}$
- B $4.5 \times 10^{-1} \text{ s}$
- C $2.2 \times 10^0 \text{ s}$
- D $4.5 \times 10^2 \text{ s}$

(Total for Question 9 = 1 mark)

10 A proton enters a magnetic field. It has a velocity v perpendicular to the field. The diagram shows the path taken by the proton.

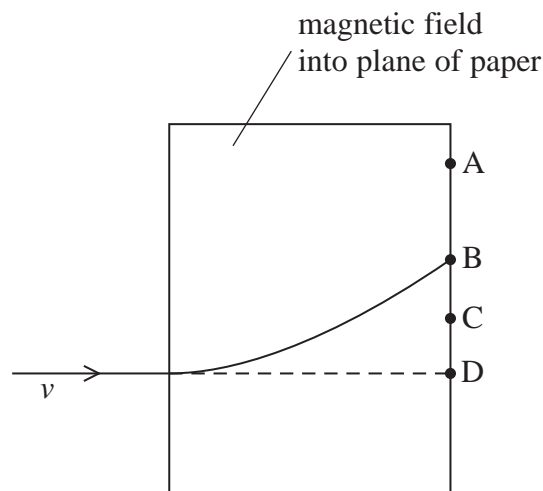

An alpha particle enters the magnetic field at the same point as the proton, also with velocity v .

At which point, A, B, C or D, is the alpha particle most likely to leave the magnetic field?

- A
- B
- C
- D

(Total for Question 10 = 1 mark)

TOTAL FOR SECTION A = 10 MARKS



DO NOT WRITE IN THIS AREA

DO NOT WRITE IN THIS AREA

DO NOT WRITE IN THIS AREA

BLANK PAGE



SECTION B

Answer ALL questions in the spaces provided.

11 The International Space Station (ISS) completes 16 orbits of the Earth every 24 hours. The ISS is 330 km above the surface of the Earth.

(a) Show that the angular velocity of the ISS around the Earth is about $1 \times 10^{-3} \text{ rad s}^{-1}$. (2)

.....
.....
.....
.....

(b) Calculate the acceleration of the ISS in this orbit.

radius of Earth = 6400 km (2)

.....
.....
.....
.....

Acceleration of the ISS =

(Total for Question 11 = 4 marks)

DO NOT WRITE IN THIS AREA

DO NOT WRITE IN THIS AREA

DO NOT WRITE IN THIS AREA



12 There are two families of hadrons called mesons and baryons.

(a) State the structure of a meson.

(1)

(b) The table shows the charge on up and down quarks.

Quark	Charge / e
up	$+2/3$
down	$-1/3$

Use the information in the table to state the quark composition of an antiproton and an antineutron.

(2)

Antiproton

Antineutron

DO NOT WRITE IN THIS AREA

DO NOT WRITE IN THIS AREA

DO NOT WRITE IN THIS AREA



(c) A proton has kinetic energy of 158 MeV. It annihilates with a stationary antiproton and two photons of equal energy are created.

Calculate the wavelength of the photons.

mass of stationary proton = $938 \text{ MeV}/c^2$

mass of stationary antiproton = $938 \text{ MeV}/c^2$

(4)

.....

.....

.....

.....

.....

.....

.....

.....

.....

.....

.....

.....

.....

.....

.....

.....

.....

.....

.....

.....

.....

.....

.....

Wavelength of the photons =

(Total for Question 12 = 7 marks)

DO NOT WRITE IN THIS AREA

DO NOT WRITE IN THIS AREA

DO NOT WRITE IN THIS AREA



13 In the game of air hockey, small identical discs move across a frictionless surface.

One disc moving with a velocity of 6.9 m s^{-1} collides with a stationary disc. After the collision the discs move apart as shown in the diagram.

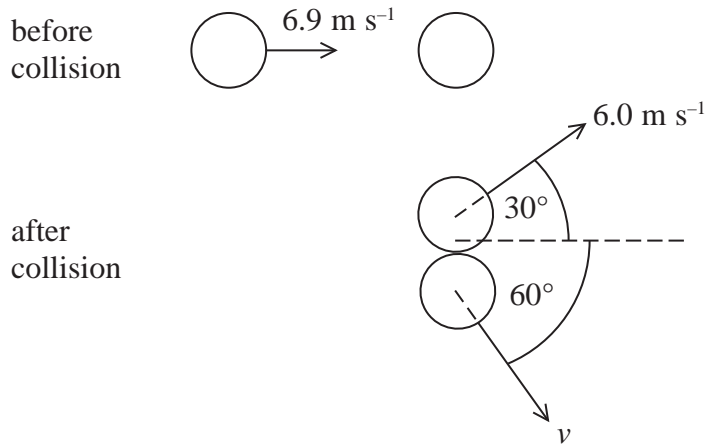

(a) Calculate the velocity v .

(3)

.....

.....

.....

.....

.....

.....

.....

.....

$v =$

(b) Explain whether the collision is elastic or inelastic.

(2)

.....

.....

.....

.....

(Total for Question 13 = 5 marks)



DO NOT WRITE IN THIS AREA

DO NOT WRITE IN THIS AREA

DO NOT WRITE IN THIS AREA

DO NOT WRITE IN THIS AREA

BLANK PAGE



P 4 6 6 5 3 A 0 1 1 3 2

- 14 A student is investigating the laws of electromagnetic induction. She drops a bar magnet through the centre of a coil of wire as shown.

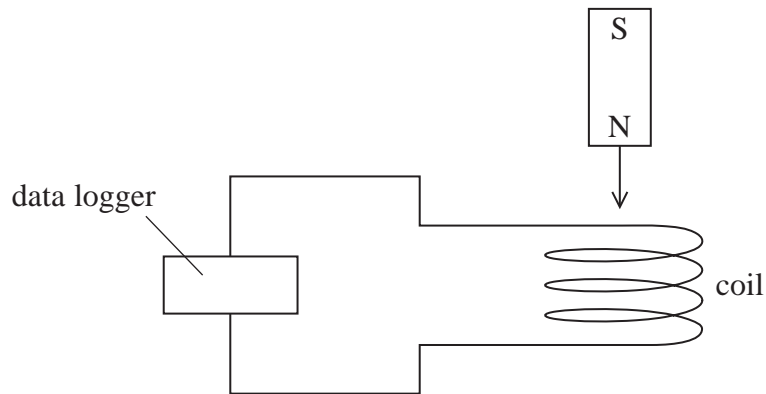

As the bar magnet falls through the coil an e.m.f ε is induced.

The graph shows how ε varies with time t .

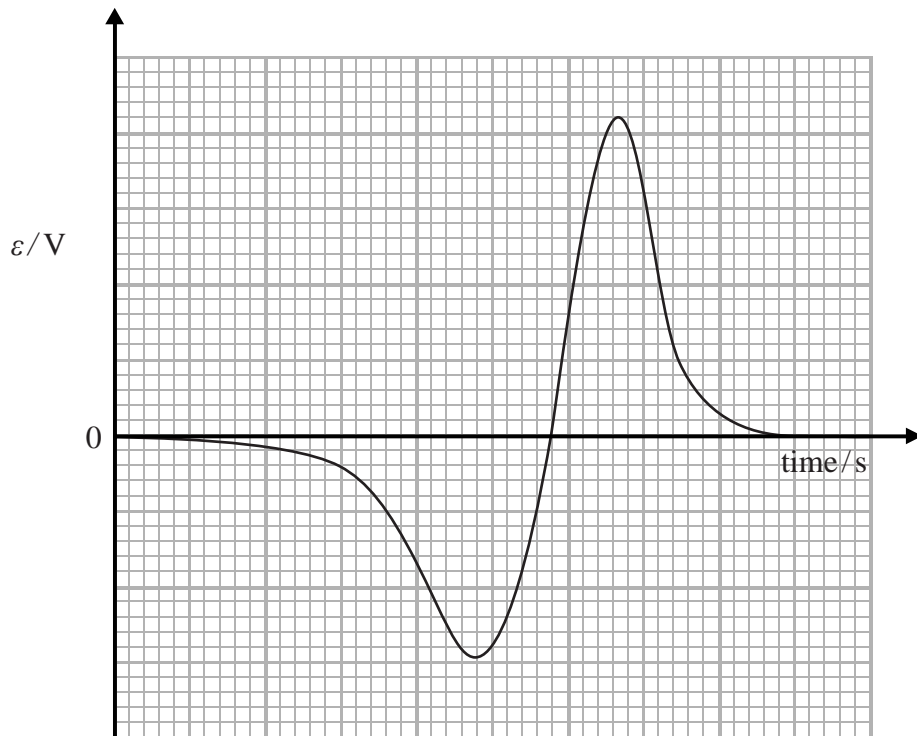

DO NOT WRITE IN THIS AREA

DO NOT WRITE IN THIS AREA

DO NOT WRITE IN THIS AREA



DO NOT WRITE IN THIS AREA

DO NOT WRITE IN THIS AREA

DO NOT WRITE IN THIS AREA

*(a) Explain the shape of the graph.

(5)

.....

.....

.....

.....

.....

.....

.....

.....

.....

.....

.....

.....

.....

.....

.....

.....

.....

.....

.....

.....

.....

.....

.....

(b) A data logger was used in this experiment rather than a voltmeter.

Describe experimental conditions that make a data logger most suitable for collecting data.

(2)

.....

.....

.....

(Total for Question 14 = 7 marks)



- 15 The photograph shows part of the cycling track used in the London 2012 Olympic Games. On the bend the track is banked so that the outside of the track is higher than the inside of the track.



The diagram shows the forces R and W acting on a cyclist travelling at a constant speed around the bend.



- (a) Explain why there must be a resultant force acting on the cyclist.

(2)

.....

.....

.....

.....

- (b) Explain why a banked track is an advantage to cyclists.

(2)

.....

.....

.....

.....



DO NOT WRITE IN THIS AREA

DO NOT WRITE IN THIS AREA

DO NOT WRITE IN THIS AREA

- (c) An inflatable airbag helmet for cyclists has been designed to prevent head injuries. It is worn like a scarf around the neck. In-built sensors detect when the cyclist is involved in a crash and inflate the airbag over the cyclist's head in 0.1 s.



The graph shows how the force on a cyclist's head during a collision varies with time when an airbag is not used.

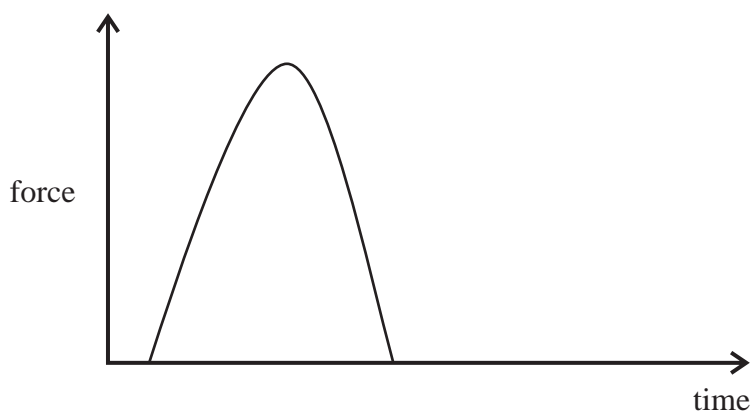

Add to the axes, the graph that shows how the force on a cyclist's head during a collision varies with time when the airbag is used.

Justify the shape of your graph.

(3)

.....

.....

.....

.....

.....

.....

.....

(Total for Question 15 = 7 marks)



- 16 A high-energy gamma photon enters a bubble chamber and produces an electron-positron pair.

The photograph shows the tracks of the electron and the positron. The gamma photon enters from the top of the photograph.

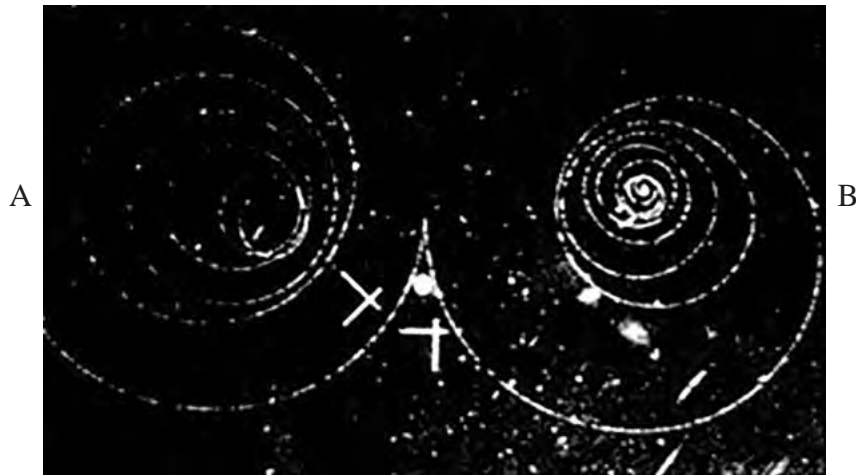

- (a) State why the photon leaves no track.

(1)

.....

.....

- (b) The magnetic field acts into the page.

State with justification whether track A or track B is the track of the electron.

(1)

.....

.....

DO NOT WRITE IN THIS AREA

DO NOT WRITE IN THIS AREA

DO NOT WRITE IN THIS AREA



*(c) Explain the shape of the electron-positron tracks.

(5)

DO NOT WRITE IN THIS AREA

DO NOT WRITE IN THIS AREA

DO NOT WRITE IN THIS AREA

(Total for Question 16 = 7 marks)



P 4 6 6 5 3 A 0 1 7 3 2

17 A student is investigating capacitance. She sets up the circuit shown.

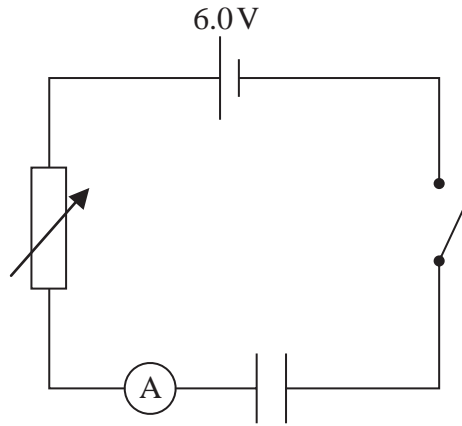

(a) When the switch is closed there is a maximum current, which decreases to zero over a period of time as the capacitor charges. Explain why.

(3)

.....

.....

.....

.....

.....

.....

(b) The student discharged the capacitor. She set the variable resistor to its maximum resistance and closed the switch. As the capacitor charged, the student decreased the resistance of the variable resistor so that the current remained constant until the capacitor was fully charged.

A graph of current against time is shown.

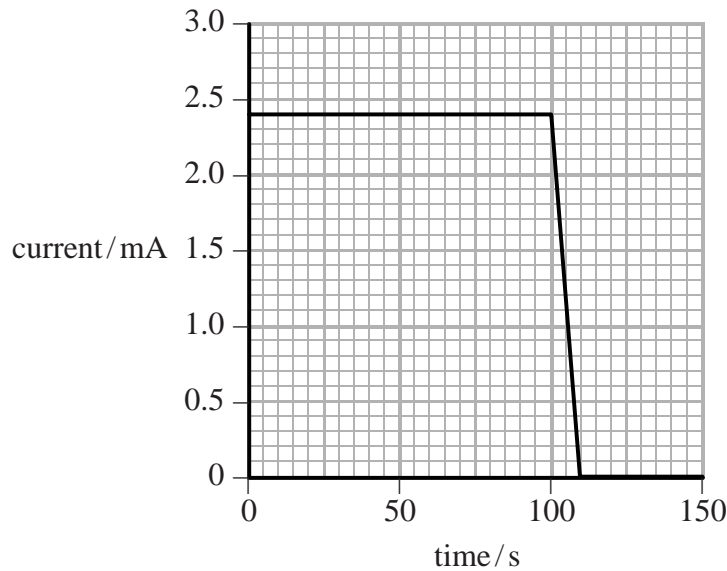

DO NOT WRITE IN THIS AREA

DO NOT WRITE IN THIS AREA

DO NOT WRITE IN THIS AREA

(i) Determine the capacitance of the capacitor.

(3)

.....

.....

.....

.....

.....

.....

Capacitance =

(ii) Hence determine the energy stored by the capacitor when it is fully charged.

(2)

.....

.....

.....

.....

Energy stored =

DO NOT WRITE IN THIS AREA

DO NOT WRITE IN THIS AREA

DO NOT WRITE IN THIS AREA



P 4 6 6 5 3 A 0 1 9 3 2

- (c) Capacitance can also be determined by measuring the current I at regular time intervals, as a capacitor discharges through a resistor, and plotting a graph of $\ln I$ against time.

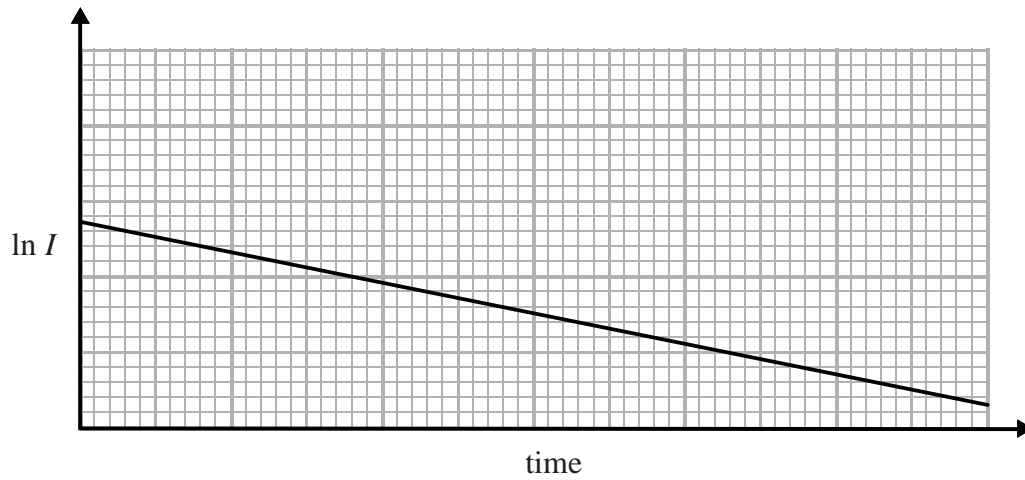

- (i) Explain how capacitance can be determined using this graph.

(3)



- (ii) A capacitor was discharged through a 390Ω resistor. The capacitance of the capacitor was calculated as $2200 \mu\text{F}$.

Explain why the data for the graph for this circuit would be difficult to obtain using an ammeter. Your answer should include a calculation.

(3)

.....

.....

.....

.....

.....

.....

.....

.....

.....

.....

(Total for Question 17 = 14 marks)

DO NOT WRITE IN THIS AREA

DO NOT WRITE IN THIS AREA

DO NOT WRITE IN THIS AREA



18 In a large-angle alpha particle scattering experiment, alpha particles were directed at thin gold foil and their paths observed. Most of the alpha particles passed straight through the foil or were deflected through a small angle. A very small number were deflected through an angle greater than 90° .

- (a) State what can be deduced about the atom given that most alpha particles passed straight through the foil.

(1)

- (b) The point below represents a gold nucleus.

Add lines to show the electric field due to the gold nucleus.

(2)



- (c) An alpha particle that is moving directly towards a gold nucleus is deflected back along its original path. The minimum separation between the alpha particle and the gold nucleus is 3.8×10^{-14} m.

atomic number of gold = 79

- (i) Calculate the electrostatic force on the alpha particle when it is at the minimum separation from the gold nucleus.

(2)

Force on alpha particle =

DO NOT WRITE IN THIS AREA

DO NOT WRITE IN THIS AREA

DO NOT WRITE IN THIS AREA



(ii) The initial kinetic energy of the alpha particle is 6.0 MeV.

Calculate the change in momentum of the alpha particle, in N s, as it travels to its minimum separation from the gold nucleus.

(3)

DO NOT WRITE IN THIS AREA

DO NOT WRITE IN THIS AREA

DO NOT WRITE IN THIS AREA

.....

.....

.....

.....

.....

.....

.....

.....

Change in momentum = N s

(Total for Question 18 = 8 marks)



P 4 6 6 5 3 A 0 2 3 3 2

DO NOT WRITE IN THIS AREA

DO NOT WRITE IN THIS AREA

DO NOT WRITE IN THIS AREA

BLANK PAGE



19 The diagrams show two particle accelerators, the cyclotron and the linac.

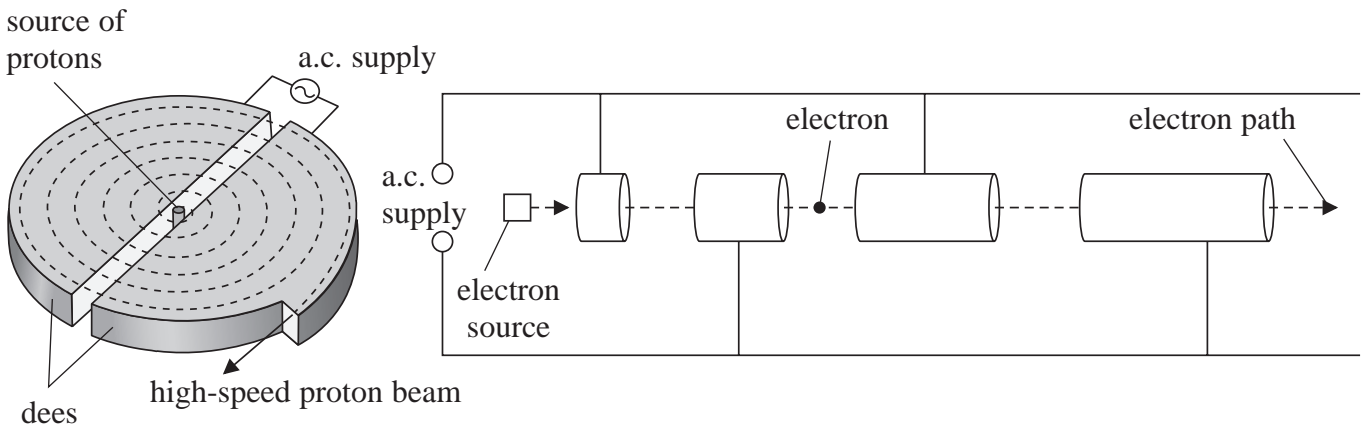

(a) Describe two similarities and two differences in how the accelerators operate.

(4)

Two similarities

.....

.....

.....

.....

Two differences

.....

.....

.....

.....

(b) (i) Electrons in an electron beam are moving at a speed of $8.2 \times 10^6 \text{ ms}^{-1}$.

Show that the de Broglie wavelength associated with these electrons is about $9 \times 10^{-11} \text{ m}$.

(2)

.....

.....

.....

.....

DO NOT WRITE IN THIS AREA

DO NOT WRITE IN THIS AREA

DO NOT WRITE IN THIS AREA



- (ii) In the 1950s physicist Robert Hofstadter used electron diffraction to estimate the diameter of the proton. He obtained a value of 5.6×10^{-25} m.

State why electrons moving at 8.2×10^6 ms⁻¹ would not be suitable for this.

(1)

DO NOT WRITE IN THIS AREA

DO NOT WRITE IN THIS AREA

DO NOT WRITE IN THIS AREA

- (c) Developments in particle accelerator technology in the 1960s enabled experiments with high-energy electrons to be carried out. At these energies, relativistic effects occur.

The graph below, of (speed)² against kinetic energy, shows data from one of these experiments.

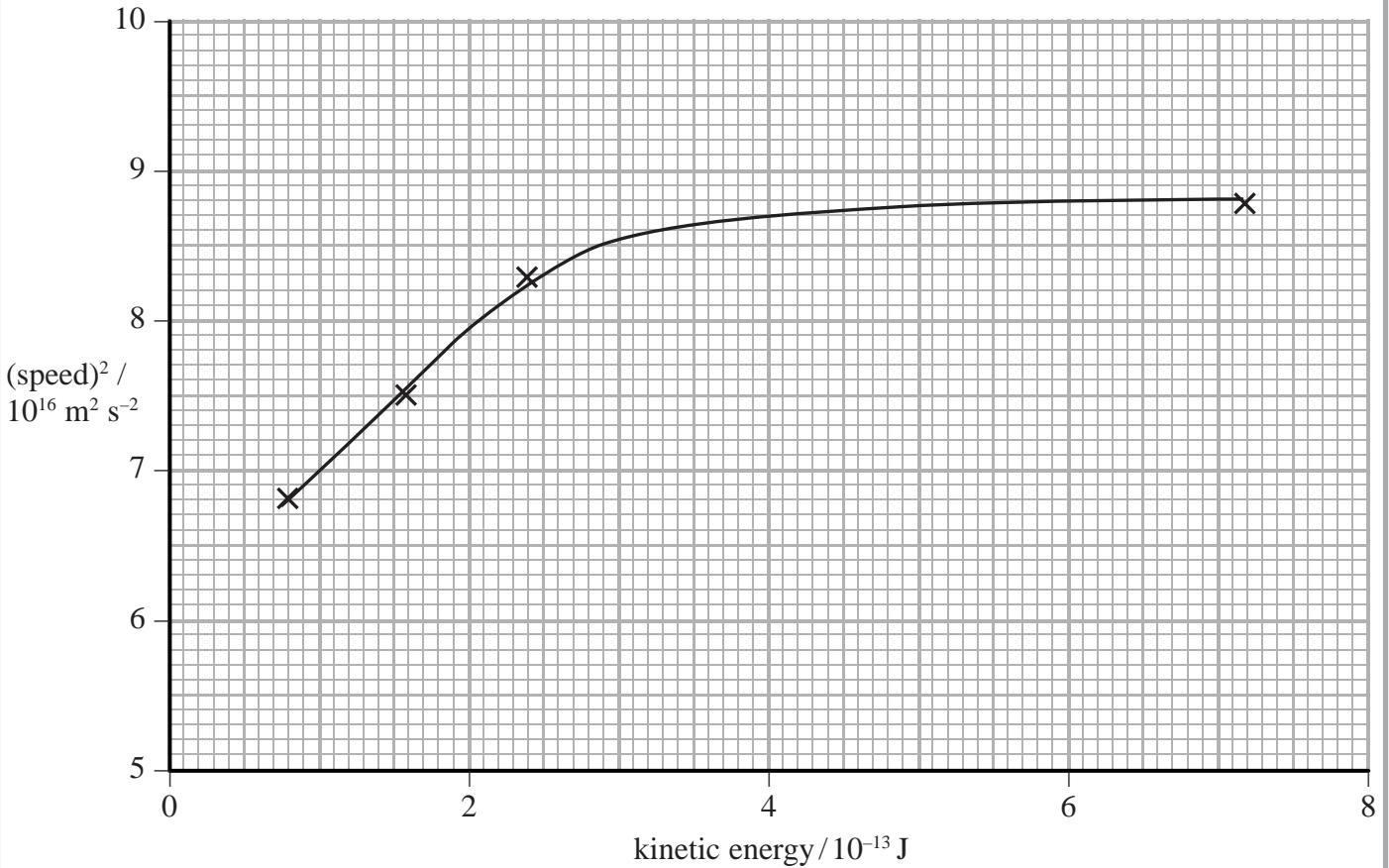

- (i) Explain why the graph levels out at a value close to 9×10^{16} m² s⁻².

(2)



(ii) The non-relativistic equation for kinetic energy, $E_k = \frac{1}{2}mv^2$, does **not** apply for high-energy electrons. Explain how the graph shows this.

(2)

.....

.....

.....

.....

.....

(Total for Question 19 = 11 marks)

TOTAL FOR SECTION B = 70 MARKS

TOTAL FOR PAPER = 80 MARKS

DO NOT WRITE IN THIS AREA

DO NOT WRITE IN THIS AREA

DO NOT WRITE IN THIS AREA



List of data, formulae and relationships

Acceleration of free fall	$g = 9.81 \text{ m s}^{-2}$	(close to Earth's surface)
Boltzmann constant	$k = 1.38 \times 10^{-23} \text{ J K}^{-1}$	
Coulomb's law constant	$k = 1/4\pi\epsilon_0$ $= 8.99 \times 10^9 \text{ N m}^2 \text{ C}^{-2}$	
Electron charge	$e = -1.60 \times 10^{-19} \text{ C}$	
Electron mass	$m_e = 9.11 \times 10^{-31} \text{ kg}$	
Electronvolt	$1 \text{ eV} = 1.60 \times 10^{-19} \text{ J}$	
Gravitational constant	$G = 6.67 \times 10^{-11} \text{ N m}^2 \text{ kg}^{-2}$	
Gravitational field strength	$g = 9.81 \text{ N kg}^{-1}$	(close to Earth's surface)
Permittivity of free space	$\epsilon_0 = 8.85 \times 10^{-12} \text{ F m}^{-1}$	
Planck constant	$h = 6.63 \times 10^{-34} \text{ J s}$	
Proton mass	$m_p = 1.67 \times 10^{-27} \text{ kg}$	
Speed of light in a vacuum	$c = 3.00 \times 10^8 \text{ m s}^{-1}$	
Stefan-Boltzmann constant	$\sigma = 5.67 \times 10^{-8} \text{ W m}^{-2} \text{ K}^{-4}$	
Unified atomic mass unit	$u = 1.66 \times 10^{-27} \text{ kg}$	

Unit 1*Mechanics*

Kinematic equations of motion	$v = u + at$ $s = ut + \frac{1}{2}at^2$ $v^2 = u^2 + 2as$
Forces	$\Sigma F = ma$ $g = F/m$ $W = mg$
Work and energy	$\Delta W = F\Delta s$ $E_k = \frac{1}{2}mv^2$ $\Delta E_{\text{grav}} = mg\Delta h$

Materials

Stokes' law	$F = 6\pi\eta rv$
Hooke's law	$F = k\Delta x$
Density	$\rho = m/V$
Pressure	$p = F/A$
Young modulus	$E = \sigma/\epsilon$ where Stress $\sigma = F/A$ Strain $\epsilon = \Delta x/x$
Elastic strain energy	$E_{\text{el}} = \frac{1}{2}F\Delta x$

DO NOT WRITE IN THIS AREA

DO NOT WRITE IN THIS AREA

DO NOT WRITE IN THIS AREA



Unit 2**Waves**Wave speed $v = f\lambda$ Refractive index ${}_1\mu_2 = \sin i / \sin r = v_1 / v_2$ **Electricity**Potential difference $V = W/Q$ Resistance $R = V/I$

Electrical power, energy and efficiency

$$P = VI$$

$$P = I^2R$$

$$P = V^2/R$$

$$W = VI t$$

$$\% \text{ efficiency} = \frac{\text{useful energy output}}{\text{total energy input}} \times 100$$

$$\% \text{ efficiency} = \frac{\text{useful power output}}{\text{total power input}} \times 100$$

Resistivity $R = \rho l/A$

Current

$$I = \Delta Q / \Delta t$$

$$I = nqvA$$
Resistors in series $R = R_1 + R_2 + R_3$ Resistors in parallel $\frac{1}{R} = \frac{1}{R_1} + \frac{1}{R_2} + \frac{1}{R_3}$ **Quantum physics**Photon model $E = hf$ Einstein's photoelectric equation $hf = \phi + \frac{1}{2}mv_{\max}^2$ 

DO NOT WRITE IN THIS AREA

Unit 4**Mechanics**

Momentum	$p = mv$
Kinetic energy of a non-relativistic particle	$E_k = p^2/2m$
Motion in a circle	$v = \omega r$ $T = 2\pi/\omega$ $F = ma = mv^2/r$ $a = v^2/r$ $a = r\omega^2$

Fields

Coulomb's law	$F = kQ_1Q_2/r^2$ where $k = 1/4\pi\epsilon_0$
Electric field	$E = F/Q$ $E = kQ/r^2$ $E = V/d$
Capacitance	$C = Q/V$
Energy stored in capacitor	$W = \frac{1}{2}QV$
Capacitor discharge	$Q = Q_0 e^{-t/RC}$
In a magnetic field	$F = BIl \sin \theta$ $F = Bqv \sin \theta$ $r = p/BQ$
Faraday's and Lenz's Laws	$\epsilon = -d(N\phi)/dt$

Particle physics

Mass-energy	$\Delta E = c^2 \Delta m$
de Broglie wavelength	$\lambda = h/p$

DO NOT WRITE IN THIS AREA

DO NOT WRITE IN THIS AREA

DO NOT WRITE IN THIS AREA



DO NOT WRITE IN THIS AREA

DO NOT WRITE IN THIS AREA

DO NOT WRITE IN THIS AREA

BLANK PAGE



P 4 6 6 5 3 A 0 3 1 3 2

DO NOT WRITE IN THIS AREA

DO NOT WRITE IN THIS AREA

DO NOT WRITE IN THIS AREA

BLANK PAGE

