

**MARK SCHEME for the May/June 2011 question paper
for the guidance of teachers**

7010 COMPUTER STUDIES

7010/11

Paper 1, maximum raw mark 100

This mark scheme is published as an aid to teachers and candidates, to indicate the requirements of the examination. It shows the basis on which Examiners were instructed to award marks. It does not indicate the details of the discussions that took place at an Examiners' meeting before marking began, which would have considered the acceptability of alternative answers.

Mark schemes must be read in conjunction with the question papers and the report on the examination.

- Cambridge will not enter into discussions or correspondence in connection with these mark schemes.

Cambridge is publishing the mark schemes for the May/June 2011 question papers for most IGCSE, GCE Advanced Level and Advanced Subsidiary Level syllabuses and some Ordinary Level syllabuses.

Page 2	Mark Scheme: Teachers' version	Syllabus	
	GCE O LEVEL – May/June 2011	7010	

- 1 Any **three** from:
- handling interrupts
 - input/output/peripheral/device control
 - spooling
 - multitasking/JCL/batch processing
 - multiprogramming
 - user interface
 - load/run software
 - processor management/task management
 - file (copy/save/delete etc) management
 - memory management
 - user accounts
 - utility tasks (defrag, format etc.)
 - error reporting/handling
 - security management
 - power management
- [3]
- 2 (a) Any **one** point from:
- program searches documents for key words/query and returns a list
 - software that searches for sites based on words input
 - use their own database to locate data defined by key words/query input
- [1]
- (b) Any **two** points from:
- too wide a search/too much information/irrelevant information found
 - “unwanted”/undesirable sites found during the search
 - picks up words with same spelling but different meaning
 - search engine loyalty/funded by advertising puts websites top of list
 - may produce out of date sites
 - misleading/incorrect information
- [2]
- (c) Any **three** features from:
- shopping basket
 - checkout
 - secure credit card payment
 - hyperlinks to other sites
 - drop down boxes/calendar with available dates
 - virtual tour of the hotel/hotel facilities
 - currency conversions
 - interactive map/directions to hotel/contact details
 - drop down boxes with room rates
 - confirmation by email/textmessage
 - form to fill in customer details/booking form
 - special offers
- [3]

Page 3	Mark Scheme: Teachers' version	Syllabus	
	GCE O LEVEL – May/June 2011	7010	

- 3 (a) Any **one** from:
- prevents unauthorised access to files/the computer system
 - access to her own directories
 - allow authorised access
- [1]
- (b) Any **one** from:
- verification check
 - (double check) password is correct
- [1]
- (c) Any **two** from:
- firewall
 - anti-virus software
 - (automatic) backup of data
 - auto-save
- [2]
- (d) (i) Any **one** from:
- repetitive strain injury (RSI) / pain in wrist/fingers
 - carpal tunnel syndrome
 - headaches/eyestrain/back ache/neck ache
- [1]
- (ii) Any **one** from:
- “lock” computer system
 - automatic screen saver (after short time of inactivity)
 - log off from the system
 - if computer in an office, lock the office door
- [1]
- 4 (a) **W** = User Interface
X = Inference Engine
Y = Expert System Shell
Z = Knowledge Base
- [4]
- (b) Any **one** from:
- Facts
 - Rules Base
- [1]
- (c) Any **one advantage** from:
- reduces the time taken to solve a problem
 - can predict future faults
 - can lower wage bills (less skilled work force needed)
 - can be used in countries where the necessary skills are rare
 - can have access 24/7
 - less likely to miss a question
- Any **one disadvantage** from:
- expensive system to set up/purchase
 - necessary to do training on the new system
 - must be kept up-to-date
- [2]

- (d) Any **two** examples from: e.g.
- medical diagnosis
 - diagnostics with example (car engine faults, electronic components)
 - tax/financial calculations
 - chess
 - mineral/oil prospecting
 - animal/plant classification
- [2]

5 (a)

count	number	total	x	average	OUTPUT
1		0	0		
2	15	15	1		
3	-2				
4	0				
5	8	23	2		
6	0				
7	21	44	3		
8	-8				
9	-12				
10	1	45	4		
11	25	70	5	14	14

} 1
 } 1
 } 1
 } 1

<----- 1 mark ----->< - 1 mark ->< - 1 mark ->< ----- 1 mark -----> [4]

(b) Find the average of all positive numbers entered [1]

- 6 Any **three** points from:
- computer s/ware helps produce more realism
 - ability to "move" mouth properly to accurately mimic speech
 - can store frames straight to dvd (or similar)
 - speeds up/simplifies editing process
 - removes need for several artists to draw the animations
 - use of tweening speeds up the process
 - reference to morphing
 - reference to avatars
 - reference to avars (animation variables)
 - reference to rendering
- [3]

7 (a) (i) = B5/C5 [1]

(ii) = (D2 + D3 + D4 + D5 + D6)/5 OR
 = AVERAGE(D2:D6) OR
 = SUM(D2:D6)/5 [1]

- (b) Any **one** from:
- character/type check
 - range check
 - format check
- [1]

(c)

	E	F	G
1	<i>Percent discount (%)</i>	Discount amount (\$)	Discounted price per bottle (\$)
2	10	= B2 * E2/100	= B2 – F2
3	20	= B3 * E3/100	= B3 – F3
4	15	= B4 * E4/100	= B4 – F4
5	10	= B5 * E5/100	= B5 – F5
6	5	= B6 * E6/100	= B6 – F6

NOTE: 1 mark for first formula in F2
1 mark for replication of formula in F3 through to F6
1 mark for first formula in G2
1 mark for replication of formula in G3 through to G6

[4]

Page 6	Mark Scheme: Teachers' version	Syllabus
	GCE O LEVEL – May/June 2011	7010

- 8 (a) 1 mark for naming the sensor + 1 mark for correct application of named sensor
(applications MUST be different)

Named sensor	Application of named sensor
Humidity Moisture (water)	greenhouse environmental control spin drier in automatic washing machine libraries/archives where moisture levels need controlling
oxygen	fish tank/aquarium environmental monitoring car engine management system/fuel injection system
light	burglar alarm automatic doors greenhouse environmental control
infra red	automatic doors car in correct place to allow paint spraying in car factory burglar alarm
pressure	traffic control automatic doors burglar alarm
gas	Environmental monitoring Safety system

[6]

Page 7	Mark Scheme: Teachers' version	Syllabus
	GCE O LEVEL – May/June 2011	7010

(b) Any **three** points from:

- sensor relays reading back to computer
- if reading is analogue, need an analogue to digital converter (ADC)
- computer compares reading with stored value
- sends signal to actuators
- signal converted using digital to analogue converter (DAC)
- actuator alters factors such as heating, coolers, etc.
- cycle continues / output affects input

accept a diagram such as:

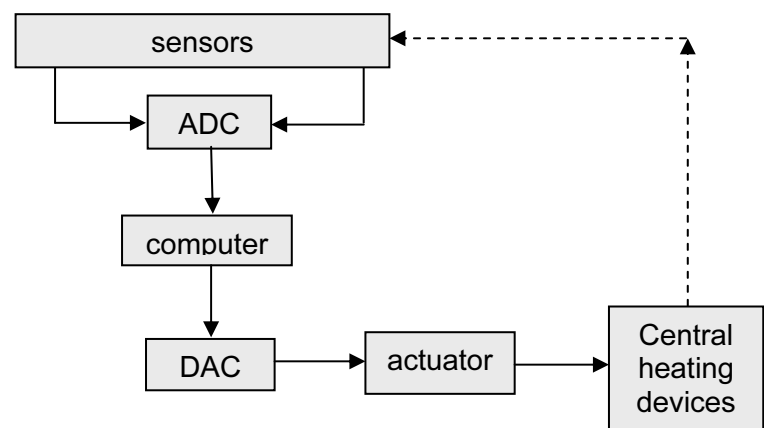

[3]

How to mark a diagram:

- 1 mark for link between sensor(s) and computer
- 1 mark for showing an ADC
- 1 mark for showing a DAC
- 1 mark for link from computer to actuator
- 1 mark for arrow implying cycling of system

9 (a) Any **four** points from:

- each "conference room" needs to log into system
- delegates speak into microphone
- webcam takes video image
- uses Internet/WAN/broadband/modem to transmit data
- use of compression software for video/audio
- use of CODEC (which converts and compresses analogue data into digital data and sends over digital links)
- echo cancellation software (allows talking in real time/keeps everything in sync)
- video images seen (on screen)/audio heard (using speakers) in real time

[4]

(b) Any **two** points from:

- faster communications now available (e.g. high speed broadband)
- safety reasons (e.g. risk of terrorism attacks on flights)
- costs (saves on overseas travelling/hotel costs)
- cheaper equipment costs

[2]

10 (a)

AND gate

A	B	X
0	0	0
0	1	0
1	0	0
1	1	1

OR gate

A	B	X
0	0	0
0	1	1
1	0	1
1	1	1

(1 mark for correct X column in each gate)

[2]

(b)

A	B	C	X
0	0	0	0
0	0	1	0
0	1	0	1
0	1	1	0
1	0	0	0
1	0	1	0
1	1	0	1
1	1	1	1

} 1
 } 1
 } 1
 } 1

[4]

11 (a)

- Any **three** features from: e.g.
- rotate, enlarge, change colour etc.
 - costings
 - library of parts
 - validation of design against specification
 - ability to do 2D/3D designs
 - link into CAM
 - create engineering drawings from solid models
 - calculate/test mass, stress etc. in new designs
 - electronic component packing

[3]

(b)

- Any **three** from: e.g.
- architecture (houses, office blocks, etc.)
 - engineering (bridges, roads, etc.)
 - interior design (kitchens, bathrooms, etc.)
 - water supply/sewer systems
 - aerospace
 - car (vehicle) design
 - chemical/nuclear plant design
 - factory layouts
 - consumer goods design (e.g. mobile phones)
 - ship building
 - fashion design
 - design of electronic components

[3]

Page 9	Mark Scheme: Teachers' version	Syllabus
	GCE O LEVEL – May/June 2011	7010

- 12 (a) Any **three** points from:
- satellites transmit signals to sat nav computer
 - computer receives/interprets these signals
 - system depends on very accurate timing/use of atomic clocks
 - each satellite transmits data including location and time
 - computer in taxi calculates its position based on at least 3 satellites
 - at least 24 satellites in operation at a given time
 - position of vehicle is within 1 metre
 - refer to triangulation:

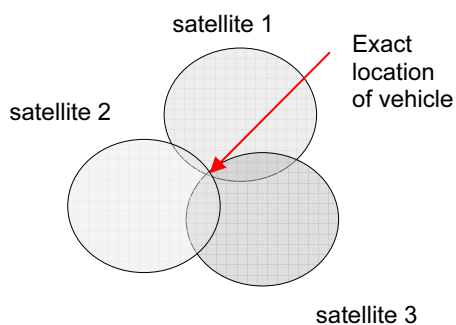

[3]

- (b) Any **two** points from:
- maps stored in sat nav memory
 - shows directions on a screen
 - voice output gives driver directions/instructions
 - plots route in advance
 - GPS knows exactly where vehicle is
 - recalculates route if driver makes a mistake

[2]

- (c) Any **one** point from:
- can estimate time of arrival
 - can warn of speed cameras (etc.)
 - can warn of road works/diversions/traffic congestion
 - can warn if exceeding speed limit
 - can give fastest/most scenic route etc.
 - can give location of petrol station/hotel etc

[1]

- (d) Any **two** reasons from:
- wrong/outdated maps stored on system
 - inaccurate timing
 - (temporary) loss of signal
 - incorrect start point/end point selected/keyed in
 - road works/accident have closed the "expected" route

[2]

Page 10	Mark Scheme: Teachers' version	Syllabus
	GCE O LEVEL – May/June 2011	7010

- 13 (a) Any **three** points from:
- collect data at different times of the day
 - data collected by filling in paper records
 - can use hand held devices to collect data
 - use of sensors to collect data
 - time how long it takes for vehicle to cross junction
 - count number of vehicles in all directions
- [3]

- (b) Any **two** points from:
- much safer (if errors made in real life, could be fatal)
 - less costly (can try out things first on the model) **NEED REASON**
 - able to test out various scenarios first
 - can optimise timings of lights etc. at junctions
 - model can be applied to other junctions
 - much quicker than doing the real thing
- [2]

14 (a) 1 mark for name + correct drawing of each type of network

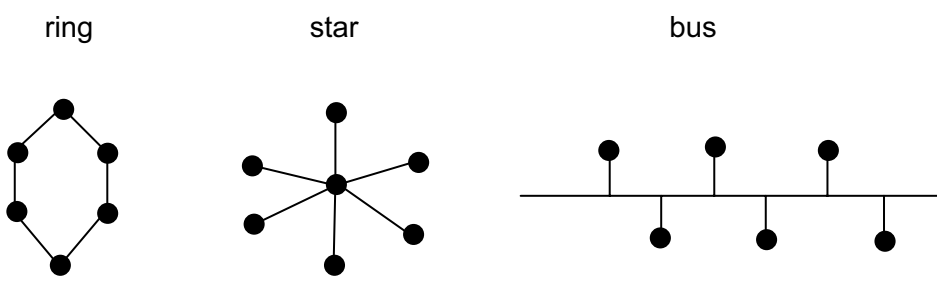

[2]

- (b) Any **two** advantages from:
- sharing of resources (hardware and software)
 - easier to communicate computer to computer
 - central database – thus all users share same information
 - easier to control what users can do (e.g. block Internet access)
 - can work from any station and access data
- [2]

15 (a) 10 [1]

(b) 2, 3, 8, 10

*1 mark per **two** correct records*

Loose 1 mark for each additional record

[2]

(c) (**Area = "Asia" AND (City Population(m) > 17 OR Urban Population(m) > 20)**)

<----- 1 mark -----> <----- 1 mark ----->

OR

(**Area = "Asia" AND City Population(m) > 17**) OR (**Area = "Asia" AND Urban Population(m) > 20**)

<----- 1 mark -----> <----- 1 mark ----->

[2]

Page 11	Mark Scheme: Teachers' version	Syllabus
	GCE O LEVEL – May/June 2011	7010

- (d) Any **one** advantage from:
- less likely for entry/typing errors
 - uses less memory to store records
 - faster data entry

16 *PENDOWN*

LEFT 90
REPEAT 3
FORWARD 30
RIGHT 90 } 1 mark

ENDREPEAT
FORWARD 10
LEFT 90 OR **PENUP** } 1 mark

PENUP OR **LEFT 90**
FORWARD 10
PENDOWN } 1 mark

REPEAT 2 OR **REPEAT 3**
FORWARD 20 } 1 mark

RIGHT 90
ENDREPEAT
FORWARD 20 OR **(LEFT/RIGHT 180)**
(LEFT 90) } 1 mark

Give a mark for each correct group of statements

[5]

Alternative answer for last 2 marks:

FORWARD 20
RIGHT 90 } 1 mark

FORWARD 20
RIGHT 90
FORWARD 20 } 1 mark

Page 12	Mark Scheme: Teachers' version	Syllabus
	GCE O LEVEL – May/June 2011	7010

```
17 (a) input name$
input H, M
if name$ = "Mexico" then H = H - 7
    else if name$ = "India" then H = H + 4: M = M + 30
    else if name$ = "New Zealand" then H = H + 11
    else print "error"
print H, M
```

Marking points

- 1 mark for two inputs for country and hours/mins
- 1 mark for check on *Mexico*
- 1 mark for check on New Zealand
- 1 mark for check on *India*
- 1 mark for error check
- 1 mark for output in correct place [4]

- (b) Any **two** sets of test data from:
- Normal hours: (hours which do not change the day) e.g. 8
 - hours which change the day (e.g.. 13 + country = New Zealand)
 - Normal minutes (which do not change the hour) eg.25
 - minutes which change the hour (e.g. 40 + country=India) [2]