



UNIVERSITY OF CAMBRIDGE INTERNATIONAL EXAMINATIONS
General Certificate of Education Ordinary Level

CANDIDATE
NAME

CENTRE
NUMBER

| | | | | |
|--|--|--|--|--|
| | | | | |
|--|--|--|--|--|

CANDIDATE
NUMBER

| | | | |
|--|--|--|--|
| | | | |
|--|--|--|--|



PHYSICS

5054/22

Paper 2 Theory

October/November 2012

1 hour 45 minutes

Candidates answer on the Question Paper.

No Additional Materials are required.

READ THESE INSTRUCTIONS FIRST

Write your Centre number, candidate number and name on all the work you hand in.

Write in dark blue or black pen.

You may use a soft pencil for any diagrams, graphs or rough working.

Do not use staples, paper clips, highlighters, glue or correction fluid.

DO **NOT** WRITE IN ANY BARCODES.

Section A

Answer **all** questions.

Write your answers in the spaces provided on the Question Paper.

Section B

Answer any **two** questions.

Write your answers in the spaces provided on the Question Paper.

You may lose marks if you do not show your working or if you do not use appropriate units.

At the end of the examination, fasten all your work securely together.

The number of marks is given in brackets [] at the end of each question or part question.

| For Examiner's Use | |
|--------------------|--|
| Section A | |
| Q9 | |
| Q10 | |
| Q11 | |
| Total | |

This document consists of **16** printed pages.



Section A

Answer **all** the questions in this section. Answer in the spaces provided.

- 1 (a) Describe an experiment to verify *the principle of moments*. You may include a diagram in your answer.

.....
.....
.....
.....
..... [4]

- (b) Fig. 1.1 shows a spanner tightening a nut.

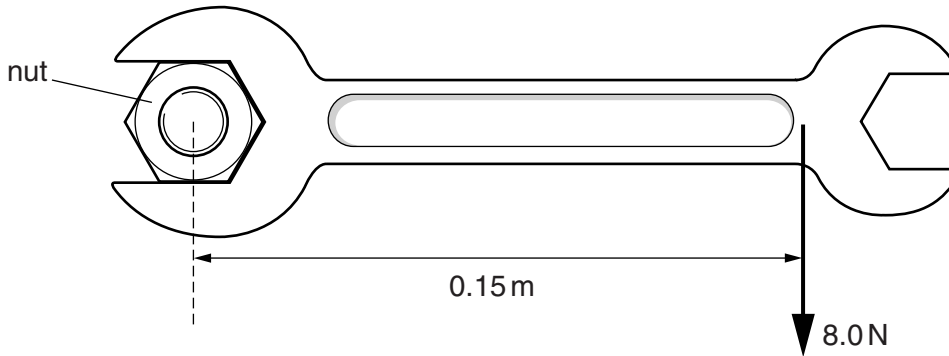

Fig. 1.1

A force of 8.0 N is applied to the spanner at a perpendicular distance of 0.15 m from the centre of the nut.

Calculate the moment of the force acting on the nut.

moment = [2]

2 A pupil hangs a load of 45 N from a length of copper wire. The wire extends by 2.5 mm and does not exceed the limit of proportionality.

(a) (i) The gravitational field strength is 10 N/kg. Calculate the mass of the 45 N load.

mass =[1]

(ii) Use the grid in Fig. 2.1 to plot the extension-load graph for this wire for a load between 0 and 45 N.

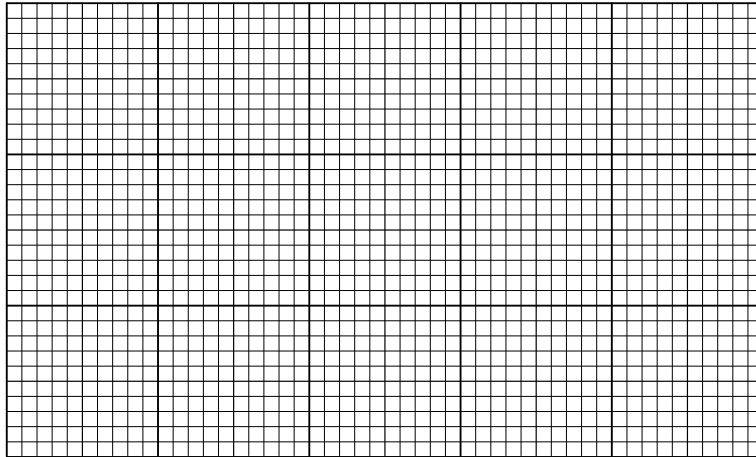

Fig. 2.1 [3]

(b) Use the graph plotted in Fig. 2.1 to determine the load needed to produce an extension of 1.3 mm.

load =[1]

- 3 A man of mass 75 kg falls from a platform high above a lake.
 Fig. 3.1a shows the man tied to the platform by a long elastic rope (bungee).
 Fig. 3.1b shows the man when he has fallen 20 m. After this point the rope begins to stretch.
 Fig. 3.1c shows the man at 25 m below the platform where he is first stopped by the rope.

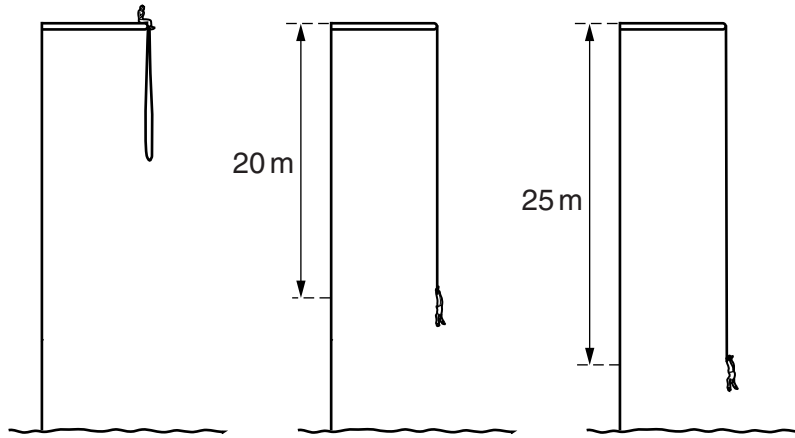

Fig. 3.1a

Fig. 3.1b

Fig. 3.1c

- (a) As the man falls, his gravitational potential energy changes.
- (i) The gravitational field strength is 10 N/kg. Calculate the change in his gravitational potential energy as he falls through 20 m.

change in potential energy = [2]

- (ii) When he is 20 m below the platform, his kinetic energy is equal to the change in his gravitational potential energy calculated in (i). Calculate his speed at this point.

speed = [3]

- (b) State the energy changes that take place as he falls from 20 m to 25 m below the platform. Ignore the effect of air resistance.

.....

 [3]

4 Fig. 4.1 shows gas trapped in a cylinder by a piston.

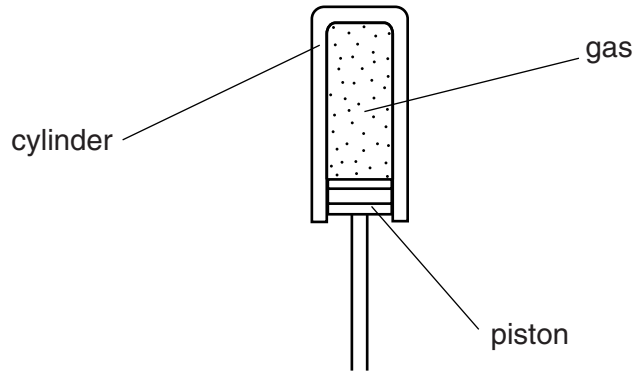

Fig. 4.1

The piston has a cross-sectional area of 0.0050 m^2 . It moves upwards, through a distance of 0.074 m , compressing the gas. During this compression, the average pressure of the gas is $4.6 \times 10^5 \text{ Pa}$.

(a) Calculate

(i) the average force exerted on the piston by the gas during compression,

force = [2]

(ii) the work done on the gas during compression.

work done = [2]

(b) The gas in the cylinder has a heat capacity of $0.27 \text{ J/}^\circ\text{C}$ and heats up as it is compressed.

(i) Calculate the maximum possible temperature rise of the gas.

temperature rise = [2]

(ii) Suggest a reason why the actual temperature rise of the gas is less than the value calculated in **(i)**.

.....
..... [1]

- 5 (a) No thermal energy (heat) is transferred from the surface of the Sun to the Earth by either conduction or convection.

Explain why this is so.

.....
.....
..... [2]

- (b) In a certain country, the climate is very sunny and hot during the day and extremely cold during the night.

Explain how painting the houses white helps to maintain a comfortable temperature both during the day and during the night.

during the day:
.....
.....

during the night:
.....
.....

[3]

6 The filament in a cathode-ray oscilloscope (c.r.o.) emits charged particles by thermionic emission.

(a) (i) State the name of the charged particles that are emitted.

..... [1]

(ii) Explain what causes the particles to be emitted.

.....
..... [1]

(iii) State why there must be a vacuum in the c.r.o. tube.

.....
..... [1]

(b) The particles emitted have a charge of size $1.6 \times 10^{-19} \text{C}$ and carry a current of $5.6 \times 10^{-3} \text{A}$ between the filament and the screen of the c.r.o.

Calculate the number of particles that strike the screen every second.

number = [2]

7 A small piece of metal taken from a nuclear reactor is radioactive.

(a) Describe a method to determine whether the piece of metal emits gamma-rays.

.....
.....
.....
.....
.....
..... [3]

(b) State two safety precautions that must be taken when handling the piece of metal.

1.
.....
2.
..... [2]

8 The nuclei of four neutral atoms are represented using nuclide notation as:



For
Examiner's
Use

(a) Neutral atoms also contain electrons. State which of the four nuclei is surrounded by the greatest number of electrons.

.....[1]

(b) From these four nuclei, state the **two** nuclei that have the same number of

(i) protons,

.....[1]

(ii) nucleons,

.....[1]

(iii) neutrons.

.....[1]

Section B

Answer **two** questions from this section. Answer in the spaces provided.

For
Examiner's
Use

- 9 Fig. 9.1 shows a diver working below the surface of a lake. The density of the water in the lake is 1000 kg/m^3 , the atmospheric pressure at the surface is $1.0 \times 10^5 \text{ Pa}$ and the gravitational field strength is 10 N/kg .



Fig. 9.1

The diver inflates a balloon with air at a depth of 15 m and attaches the balloon to a tray of objects.

(a) Calculate

- (i) the pressure due to 15 m of water,

pressure =[2]

- (ii) the total pressure at 15 m below the surface of the lake.

total pressure =[1]

(b) The air in the balloon occupies a volume of 0.048 m^3 at the pressure calculated in (a)(ii). The diver releases the tray and the balloon, and they begin to rise. The temperature of the air in the balloon does not change.

- (i) Calculate the volume occupied by the air in the balloon at atmospheric pressure.

volume =[2]

(ii) The pressure of the air inside the balloon is less at the surface than at a depth of 15m. Explain, in terms of the air molecules inside the balloon, why the pressure is less.

.....
.....
.....
..... [3]

(c) State one difference between the arrangement of the molecules of water in the lake and the molecules of air in the balloon.

.....
..... [1]

(d) When the diver releases the tray, the balloon accelerates upwards and reaches a constant speed before it arrives at the surface.

(i) Explain how the forces acting on the balloon cause it to behave in this way.

.....
.....
.....
..... [3]

(ii) On the axes in Fig. 9.2, sketch the distance-time graph for the balloon as it travels 15m to the surface.

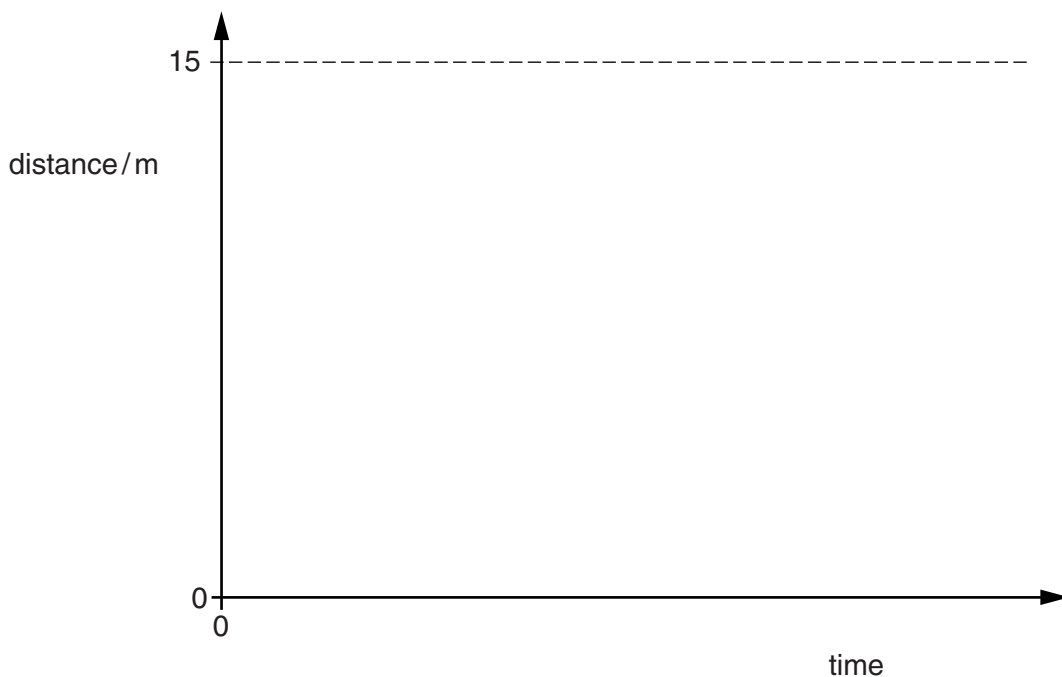

Fig. 9.2

[3]

[Turn over

10 A laser produces red light of frequency 4.7×10^{14} Hz. The speed of light in glass is 2.0×10^8 m/s.

For
Examiner's
Use

(a) Calculate the wavelength in glass of light from this laser.

wavelength = [2]

(b) Describe an experiment to verify *the law of reflection* for light. You may include a diagram in your answer.

.....

.....

.....

.....

.....

.....

.....

.....

.....

..... [5]

(c) Fig. 10.1 shows a ray of light travelling in an optical fibre. The ray strikes the side of the fibre at P.

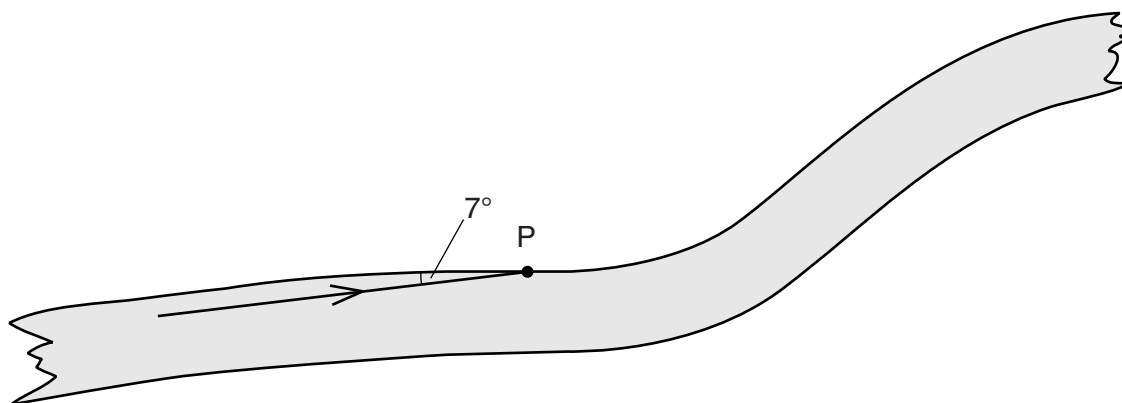

Fig. 10.1

The angle between the ray and the side of the fibre is 7°.

(i) Determine the angle of incidence of the ray at P.

angle = [1]

(ii) State and explain what happens to the ray at P.

.....

 [2]

(d) A room is illuminated by wall lamps. Fig. 10.2 shows a mirror on the wall behind one of the lamps.

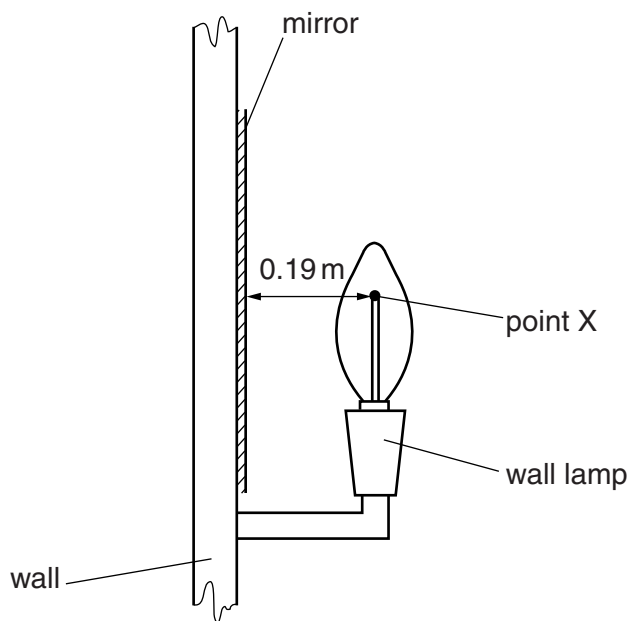

Fig. 10.2 (not to scale)

X is a point on the filament of the lamp. It is 0.19 m in front of the mirror.

(i) On Fig. 10.2, draw rays from X and locate the image of X. Label the image I. [3]

(ii) State the distance between I and the mirror.

distance = [1]

(iii) Suggest one advantage of placing a mirror behind the lamp in the room.

.....
 [1]

11 (a) A wire is wound around a soft-iron core forming a solenoid, as shown in Fig. 11.1.

For
Examiner's
Use

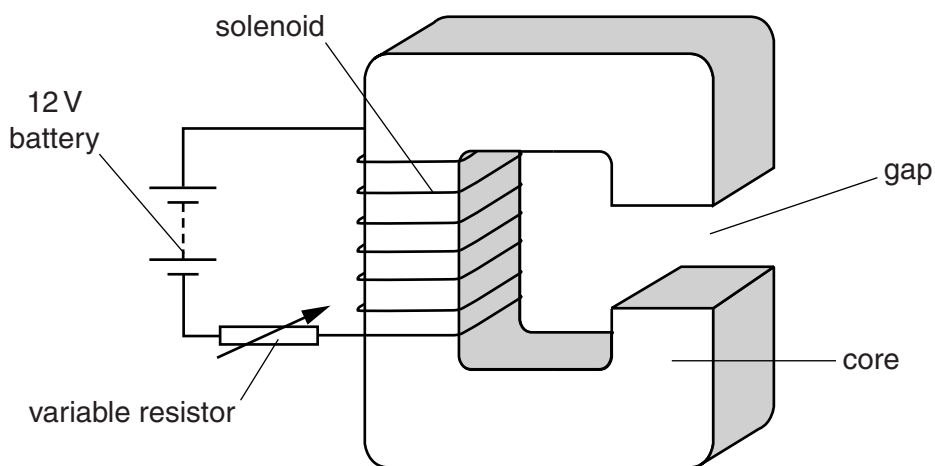

Fig. 11.1

There is a gap in the core. The solenoid is connected in series with a 12V battery and a variable resistor (rheostat). The resistance of the solenoid is 0.30Ω and the variable resistor is set so that it has a resistance of 4.5Ω .

(i) Calculate the current in the solenoid.

current =[3]

(ii) The current in the solenoid magnetises the soft-iron core.

Explain how the electric circuit is used to increase the strength of the magnetic field.

.....

[2]

(iii) Fig. 11.2 shows a horizontal, current-carrying wire PQ in the gap.

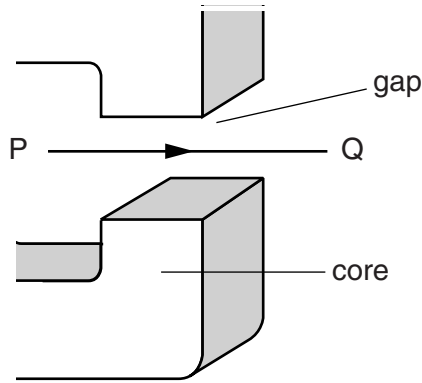

Fig. 11.2

1. The magnetic field in the gap is uniform and vertically upwards. The current in PQ is from left to right. Describe the effect of the magnetic field on PQ.

.....
 [2]

2. State the effect on PQ of increasing the strength of the magnetic field in the gap.

.....
 [1]

(b) The starter motor in a car is powered by a 12V battery that is positioned next to the motor. The current in the motor is 75 A.

(i) Calculate the power supplied by the battery.

power = [2]

(ii) Suggest and explain why the wires that connect the motor to the battery are very thick.

.....

 [2]

(c) A relay is used to switch on a starter motor in a car. Describe how the relay works. You may include a diagram in your answer.

*For
Examiner's
Use*

.....

.....

.....

..... [3]

Permission to reproduce items where third-party owned material protected by copyright is included has been sought and cleared where possible. Every reasonable effort has been made by the publisher (UCLES) to trace copyright holders, but if any items requiring clearance have unwittingly been included, the publisher will be pleased to make amends at the earliest possible opportunity.

University of Cambridge International Examinations is part of the Cambridge Assessment Group. Cambridge Assessment is the brand name of University of Cambridge Local Examinations Syndicate (UCLES), which is itself a department of the University of Cambridge.