



Cambridge International Examinations
Cambridge International General Certificate of Secondary Education

CANDIDATE
NAME

| |
|--|
| |
|--|

CENTRE
NUMBER

| | | | | |
|--|--|--|--|--|
| | | | | |
|--|--|--|--|--|

CANDIDATE
NUMBER

| | | | |
|--|--|--|--|
| | | | |
|--|--|--|--|

* 6 2 3 2 6 6 4 6 1 9 *

CHEMISTRY

0620/42

Paper 4 Theory (Extended)

February/March 2017

1 hour 15 minutes

Candidates answer on the Question Paper.

No Additional Materials are required.

READ THESE INSTRUCTIONS FIRST

Write your Centre number, candidate number and name on all the work you hand in.

Write in dark blue or black pen.

You may use an HB pencil for any diagrams or graphs.

Do not use staples, paper clips, glue or correction fluid.

DO **NOT** WRITE IN ANY BARCODES.

Answer **all** questions.

Electronic calculators may be used.

A copy of the Periodic Table is printed on page 16.

You may lose marks if you do not show your working or if you do not use appropriate units.

At the end of the examination, fasten all your work securely together.

The number of marks is given in brackets [] at the end of each question or part question.

The syllabus is approved for use in England, Wales and Northern Ireland as a Cambridge International Level 1/Level 2 Certificate.

This document consists of **14** printed pages and **2** blank pages.

(b) Petroleum can be separated into useful substances using the apparatus shown.

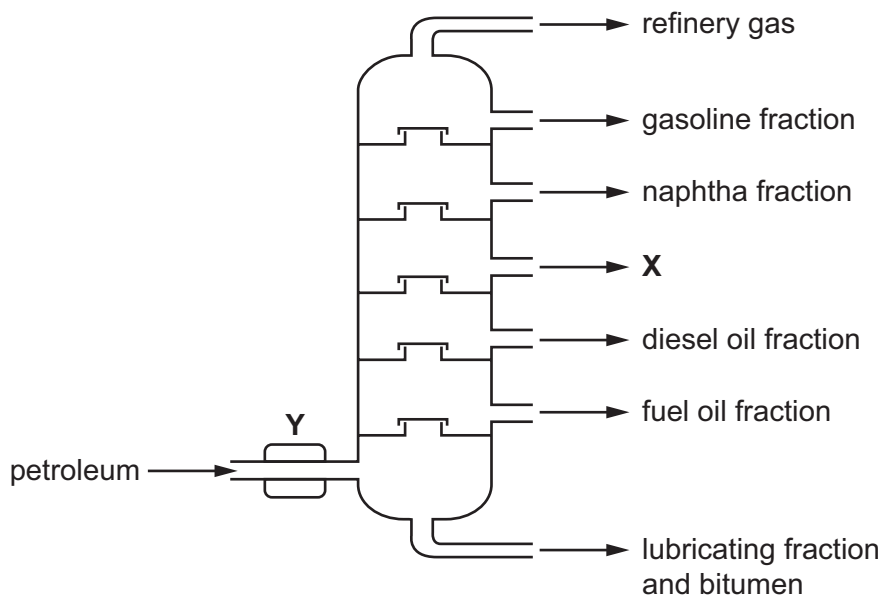

(i) Name the fraction which is the most viscous.

..... [1]

(ii) Name the fraction with the smallest molecules.

..... [1]

(iii) Name the fraction which has the weakest attractive forces between molecules.

..... [1]

(iv) Fraction **X** is used as jet fuel.

Name fraction **X**.

..... [1]

(v) What happens at point **Y** on the diagram?

..... [1]

[Total: 11]

2 Silver dichromate, $\text{Ag}_2\text{Cr}_2\text{O}_7$, is a red insoluble salt.

Silver dichromate can be made by reacting silver nitrate solution with ammonium dichromate solution. The chemical equation for the reaction is shown.

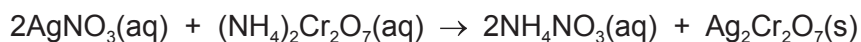

(a) Describe how you could obtain pure dry solid silver dichromate after mixing silver nitrate solution and ammonium dichromate solution.

.....

.....

.....

..... [3]

(b) (i) The charge on a silver ion is +1.

Deduce the charge on the dichromate ion in $\text{Ag}_2\text{Cr}_2\text{O}_7$.

..... [1]

(ii) Write the ionic equation for the formation of silver dichromate in this reaction. State symbols are **not** required.

..... [1]

(c) Dilute aqueous sodium hydroxide was added to the ammonium nitrate solution made in the reaction. The mixture was then warmed and damp Universal Indicator paper was held above the mixture.

State and explain what would happen to the Universal Indicator paper.

.....

.....

..... [2]

(d) The apparatus shown was set up.

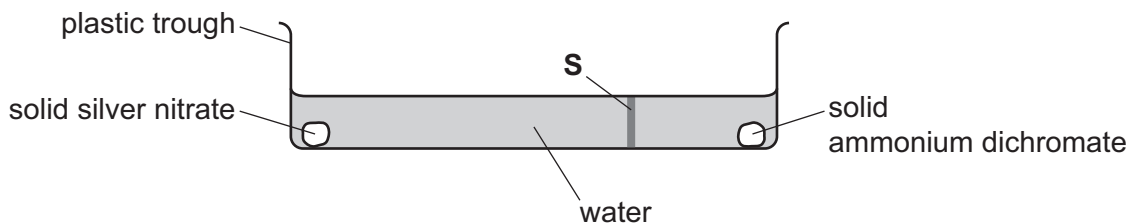

After five minutes, a red solid appeared along the line marked **S** on the diagram.

(i) Explain why a red solid appeared along the line marked **S**.

.....

.....

.....

..... [3]

(ii) The experiment was repeated at a higher temperature.

What effect, if any, would this have on the time taken for the red solid to appear? Explain your answer.

.....

..... [2]

(e) Ammonium dichromate, $(\text{NH}_4)_2\text{Cr}_2\text{O}_7$, undergoes thermal decomposition. The products are chromium(III) oxide, nitrogen and water.

(i) What is meant by *thermal decomposition*?

.....

..... [2]

(ii) Write a chemical equation for the thermal decomposition of ammonium dichromate.

..... [2]

[Total: 16]

- 3 Nitryl chloride, NO_2Cl , reacts with nitric oxide, NO . The forward reaction is exothermic.

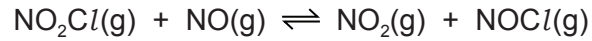

The reaction can reach equilibrium.

- (a) What is meant by the term *equilibrium* for a reversible reaction?

.....

 [2]

- (b) Explain why increasing the temperature increases the rate of reaction.

.....

 [3]

- (c) State and explain the effect, if any, of increasing the temperature on the position of equilibrium.

.....

 [2]

- (d) State and explain the effect, if any, of decreasing the pressure on the position of equilibrium.

.....

 [2]

(e) Nitrosyl chloride, NOCl , is a gas at room temperature. It has the structure shown.

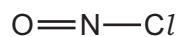

- (i) Complete the dot-and-cross diagram to show the arrangement of the outer shell electrons in nitrosyl chloride.

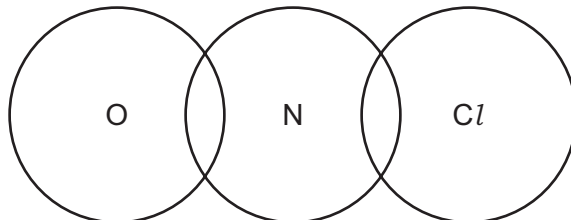

[2]

- (ii) Nitrosyl chloride has a boiling point of -6°C .

Explain why nitrosyl chloride has a low boiling point.

.....
.....
..... [2]

[Total: 13]

4 Copper(II) sulfate solution was electrolysed using the apparatus shown.

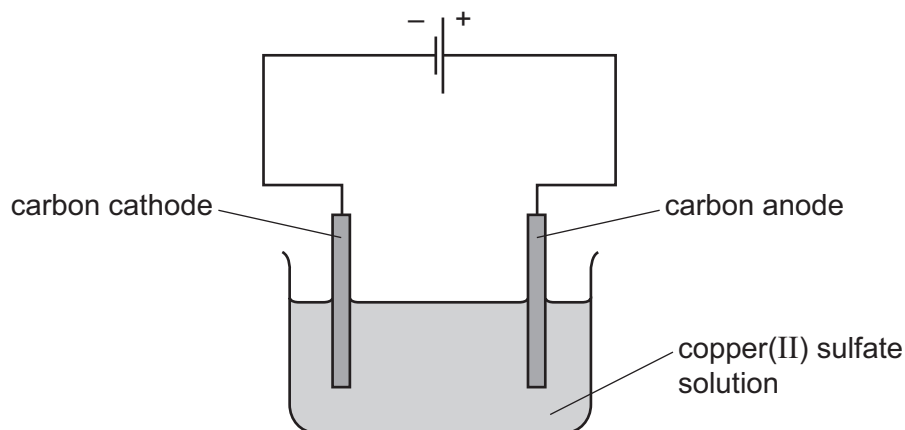

- (a) (i) Draw an arrow on the diagram to show the direction of movement of electrons in the wire. Label the arrow **A**. [1]
- (ii) Draw an arrow on the diagram to show the direction of movement of positive ions in the copper(II) sulfate solution. Label the arrow **B**. [1]

(b) Oxygen was formed at the anode and copper was formed at the cathode.

- (i) The ionic half-equation for the formation of oxygen is shown.



Explain why this reaction is oxidation.

..... [1]

- (ii) Write the ionic half-equation for the formation of copper at the cathode.

..... [2]

(c) The electrolysis was repeated using copper electrodes in place of carbon electrodes.

State and explain what happens to the masses of the anode and the cathode during this electrolysis.

.....

.....

.....

.....

..... [4]

[Total: 9]

5 Iron is extracted from its ore using a blast furnace.

(a) In the blast furnace, coke burns in oxygen to produce heat energy and carbon dioxide.

How is this carbon dioxide converted into carbon monoxide in the blast furnace?

..... [1]

(b) Calcium carbonate added to the blast furnace decomposes to form calcium oxide. Calcium oxide removes silicon(IV) oxide impurities from the iron in a neutralisation reaction.

Write a chemical equation for the reaction of calcium oxide with silicon(IV) oxide. Suggest why it is a neutralisation reaction.

.....

 [3]

(c) The main impurity in iron obtained from the blast furnace is carbon.

(i) Why must the high levels of carbon be lowered before the iron becomes a useful material?

..... [1]

(ii) How is the carbon removed from the iron?

.....
 [1]

(d) Zinc is extracted from its ore. The ore contains zinc sulfide. The zinc sulfide is roasted in air to produce zinc oxide and sulfur dioxide.

Zinc is then obtained from the zinc oxide using a blast furnace.

(i) Give the name of the ore of zinc that contains zinc sulfide.

..... [1]

(ii) Write a chemical equation for the reaction that takes place when zinc sulfide is roasted in air.

..... [1]

(iii) Suggest why the sulfur dioxide should **not** be released into the atmosphere.

.....
 [2]

- (iv) The temperature inside the blast furnace in which zinc is extracted is about 1000 °C.

The table gives some information about substances in the blast furnace in which zinc is extracted.

| substance | melting point/ °C | boiling point/ °C |
|-------------------|---------------------|-------------------|
| carbon | sublimes at 4330 °C | |
| silicon(IV) oxide | 1610 | 2230 |
| zinc | 420 | 907 |

Use the data in the table to explain why the zinc obtained does **not** contain high levels of impurities such as silicon(IV) oxide and carbon.

.....
.....
..... [2]

[Total: 12]

6 Barium carbonate decomposes when heated.

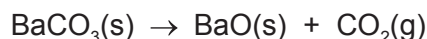

(a) A student heated a 10.0g sample of barium carbonate until it was fully decomposed.

(i) Calculate the number of moles of barium carbonate the student used.

moles of barium carbonate = mol [2]

(ii) Calculate the volume of carbon dioxide gas produced at room temperature and pressure. Give your answer in dm^3 .

volume of carbon dioxide = dm^3 [1]

(b) The student added 2.00g of the barium oxide produced to water.

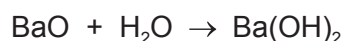

Calculate the mass of barium hydroxide that can be made from 2.00g of barium oxide. The M_r of $\text{Ba}(\text{OH})_2$ is 171.

mass of barium hydroxide = g [1]

(c) A 1.50g sample of barium hydroxide was dissolved in water. The total volume of the solution was 100 cm^3 .

A 25.0 cm^3 portion of the barium hydroxide solution was titrated against hydrochloric acid. The volume of hydrochloric acid required was 18.75 cm^3 .

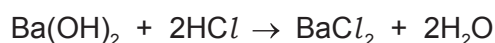

(i) Calculate how many moles of barium hydroxide were in the 25.0 cm^3 portion used in the titration.

moles of barium hydroxide = mol [1]

(ii) Calculate the concentration of the hydrochloric acid used.

concentration of hydrochloric acid = mol/dm^3 [2]

[Total: 7]

- 7 (a) The diagram shows part of the structure of an addition polymer.

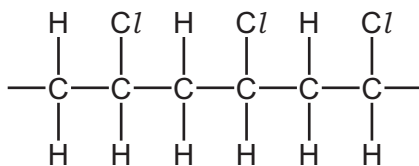

- (i) Draw a circle around **one** repeat unit of the polymer. [1]

- (ii) Draw the structure of the monomer from which this addition polymer is made.

[1]

- (iii) Aqueous bromine is added to both the polymer and the monomer.

Describe what would be seen in each case.

with the polymer

with the monomer

[2]

- (b) The diagram shows part of the structure of a condensation polymer.

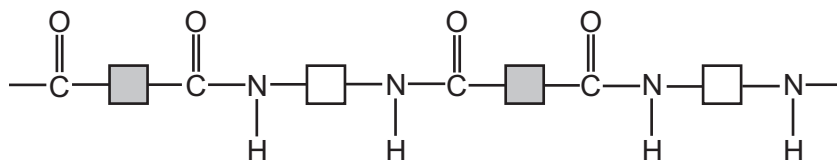

- (i) What type of condensation polymer is this?

..... [1]

- (ii) On the diagram, draw a circle around **one** repeat unit of the polymer. [1]

- (iii) Draw the structures of the **two** monomers from which the condensation polymer is made.

[2]

(c) Hydrolysis of a polymer gave a compound with the following composition by mass: C, 34.61%; H, 3.85%; O, 61.54%.

(i) Calculate the empirical formula of the compound.

empirical formula = [3]

(ii) What additional information is needed to calculate the molecular formula of the compound?

.....

..... [1]

[Total: 12]

BLANK PAGE

Permission to reproduce items where third-party owned material protected by copyright is included has been sought and cleared where possible. Every reasonable effort has been made by the publisher (UCLES) to trace copyright holders, but if any items requiring clearance have unwittingly been included, the publisher will be pleased to make amends at the earliest possible opportunity.

To avoid the issue of disclosure of answer-related information to candidates, all copyright acknowledgements are reproduced online in the Cambridge International Examinations Copyright Acknowledgements Booklet. This is produced for each series of examinations and is freely available to download at www.cie.org.uk after the live examination series.

Cambridge International Examinations is part of the Cambridge Assessment Group. Cambridge Assessment is the brand name of University of Cambridge Local Examinations Syndicate (UCLES), which is itself a department of the University of Cambridge.

