

CAMBRIDGE INTERNATIONAL EXAMINATIONS
International General Certificate of Secondary Education

GEOGRAPHY

0460/01

Paper 1

October/November 2003

Additional Materials: Answer Booklet/Paper

1 hour 45 minutes

READ THESE INSTRUCTIONS FIRST

If you have been given an Answer Booklet, follow the instructions on the front cover of the Booklet.
Write your Centre number, candidate number and name on all the work you hand in.
Write in dark blue or black pen on both sides of the paper.
You may use a soft pencil for any diagrams, graphs or rough working.
Do not use staples, paper clips, highlighters, glue or correction fluid.

Answer any **three** questions.

At the end of the examination, fasten all your work securely together.

The number of marks is given in brackets [] at the end of each question or part question.

Sketch maps and diagrams should be drawn whenever they serve to illustrate an answer.

Insert 1 contains Fig. 1 and Table 1 for Question 1.

Insert 2 contains Photograph A for Question 2 and Fig. 11 for Question 6.

This document consists of **12** printed pages and **2** inserts.



- 1 (a) Fig. 1 (Insert 1) is used to show how the population of a country may change over time.
- (i) Complete Table 1 (Insert 1) selecting your answers from the following list:
- low,*
- high,*
- falling,*
- increasing,*
- high and fluctuating,*
- low and fluctuating.* [4]
- (ii) On Fig. 1, print **X** where the rate of population growth is greatest. [1]
- (iii) Give reasons for your answer to (a)(ii). [2]
- (iv) Print **Y** on Fig. 1 where a decline in population growth is shown. [1]
- (v) State why the population growth declines at **Y**. [1]
- (b) (i) Many developing countries are found in Stages 2 and 3 of Fig. 1. Birth rates are high in these countries.
- Give reasons for these high birth rates. [4]
- (ii) Why do many developing countries wish to reduce their birth rates? [4]
- (iii) Explain the changes which are shown to take place in the death rate in Stages 2 and 3. [4]
- (iv) What problems related to population changes may face countries in Stage 4? [4]

- 2 (a) Fig. 2 shows changes in the urban population in developed and developing regions of the world in 1970 and in 1994.

Region	Urban population (millions)		Urban share (percentage)	
	1970	1994	1970	1994
<i>developed regions</i>	677	868	68	75
Australia-New Zealand	13	18	85	85
Europe	423	532	64	73
Japan	74	97	71	78
North America	167	221	74	76
<i>developing regions</i>	676	1653	25	37
Africa	84	240	23	33
Asia ^a	428	1062	21	32
Latin America	163	349	57	74
Oceania ^b	1	2	18	24

Notes: a. excluding Japan, b. excluding Australia and New Zealand. Source: United Nations, 1995.

Fig. 2

- (i) What is meant by 'urban population'? [1]
- (ii) By how many millions did the urban population increase from 1970 to 1994 in
- A** the developed regions of the world,
- B** the developing regions of the world? [2]
- (iii) Which developing region, named in Fig. 2, had the greatest share (percentage) of urban population in 1994? [1]
- (iv) How did the percentage of urban population in the developed regions compare with that in the developing regions in 1994? [2]
- (v) Which region of the world had the highest percentage of urban population in 1994? [1]
- (b) Squatter settlements often result from the rapid growth of urban population in many developing countries.

Photograph A (Insert 2) shows part of a squatter settlement on the edge of a major city in a developing country.

- (i) Why is the population of large cities in developing countries growing rapidly at the present time? [5]
- (ii) Describe the main features of the squatter settlement shown in Photograph A. [5]
- (iii) From evidence on the photograph and other facts you may know, explain some of the problems resulting from the growth of a squatter settlement
- A** for residents of such a settlement, and [5]
- B** for the local environment. [3]

3 (a) Study Figs 3A (below) and 3B (opposite).

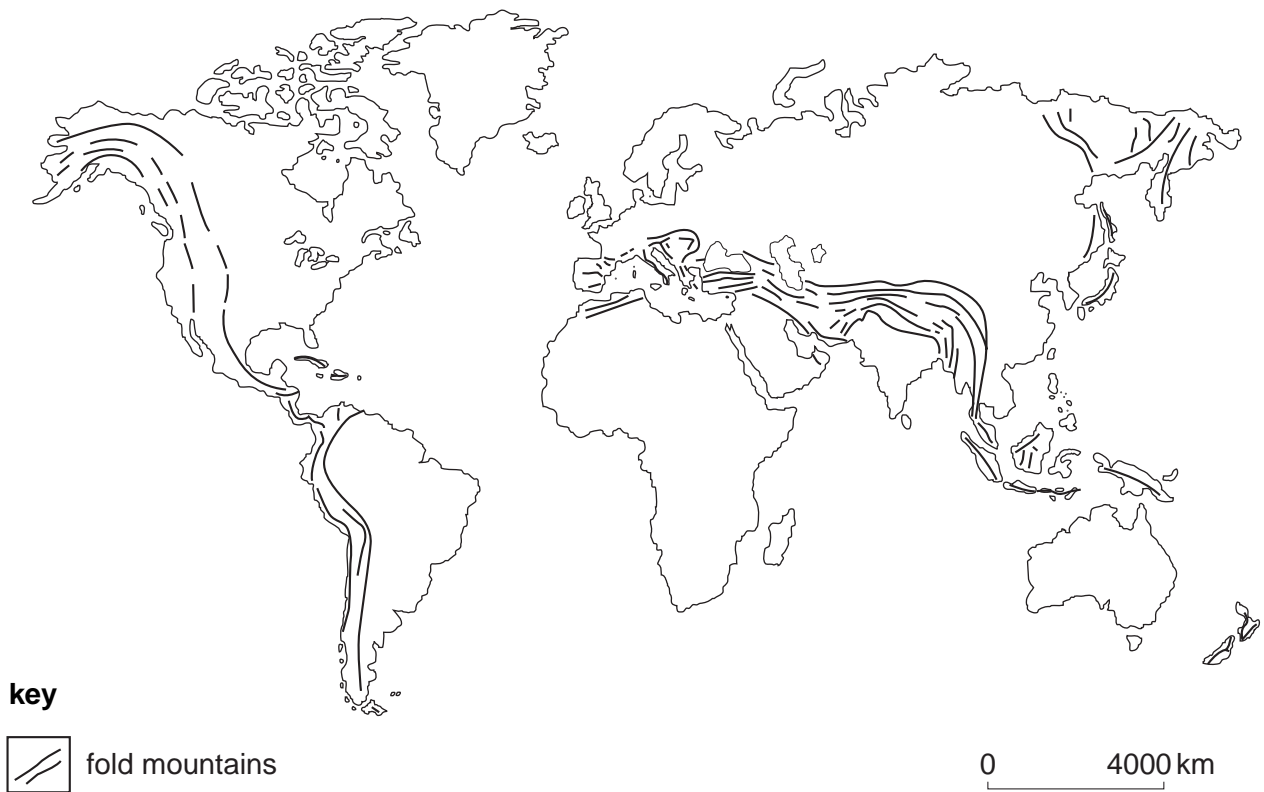

Fig. 3A

- (i) Name **two** areas of the world shown on Fig. 3A which have fold mountains. [2]
- (ii) Fig. 3B shows that earthquake belts and active volcanoes occur in similar parts of the world.
Are these the same areas as those with fold mountains shown on Fig. 3A? [1]
- (iii) Give a reason for your answer to (a)(ii). [1]
- (iv) What is meant by each of the following features shown in Figs 3A and 3B.
'fold mountains', 'earthquake belt', 'active volcanoes'? [3]
- (v) Details are given on Fig. 3B about an earthquake which occurred in Gujarat in India in 2001.
What evidence is given on Fig. 3B which suggests that this earthquake was very severe? [2]
- (vi) Why do some earthquakes cause more damage and loss of life than others? [2]

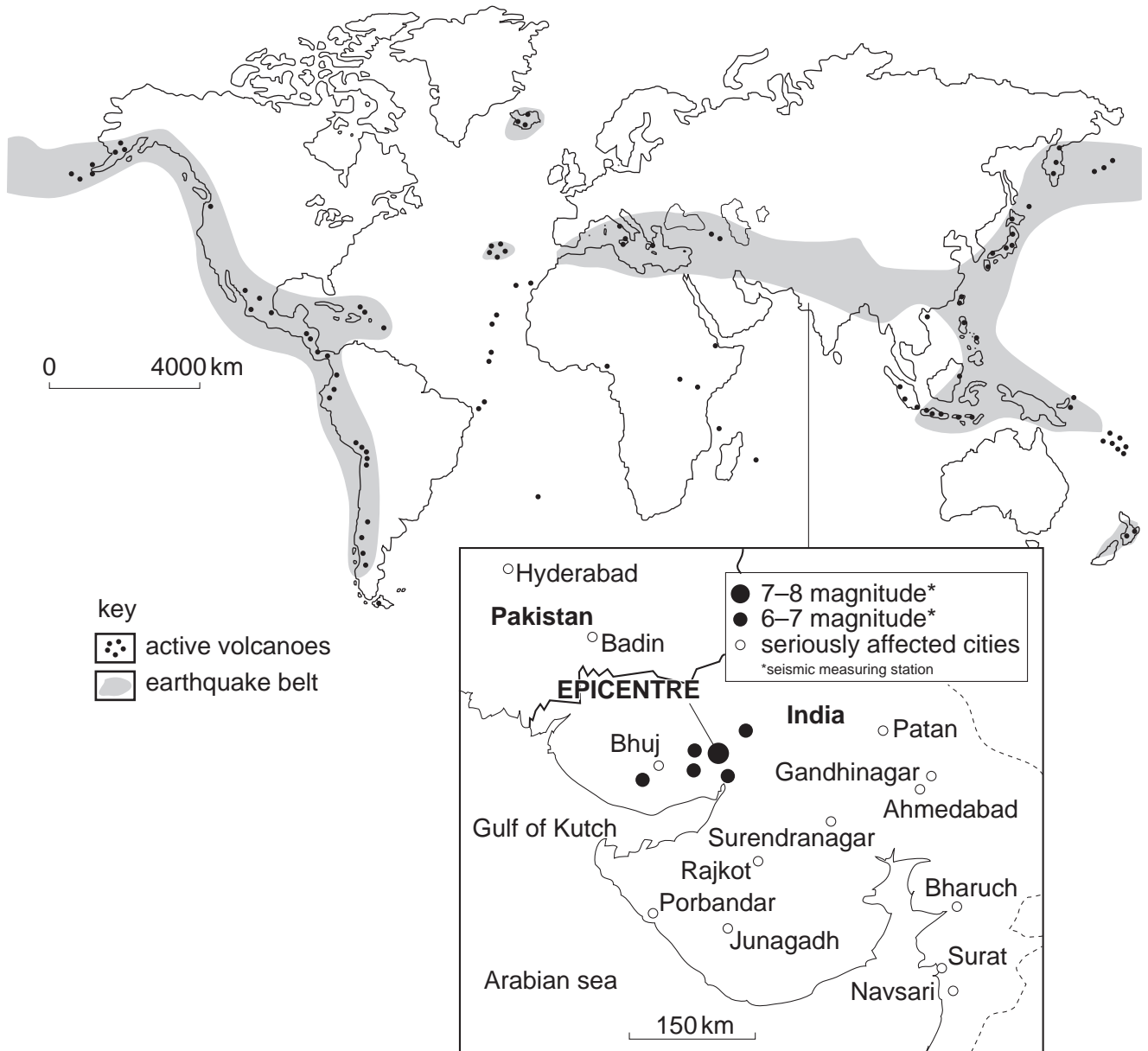

Fig. 3B
Details of the earthquake at Gujarat (India) in 2001

(Question 3 continues on p6.)

(b) Fig. 4 shows a section through each of two volcanoes **E** and **F**.

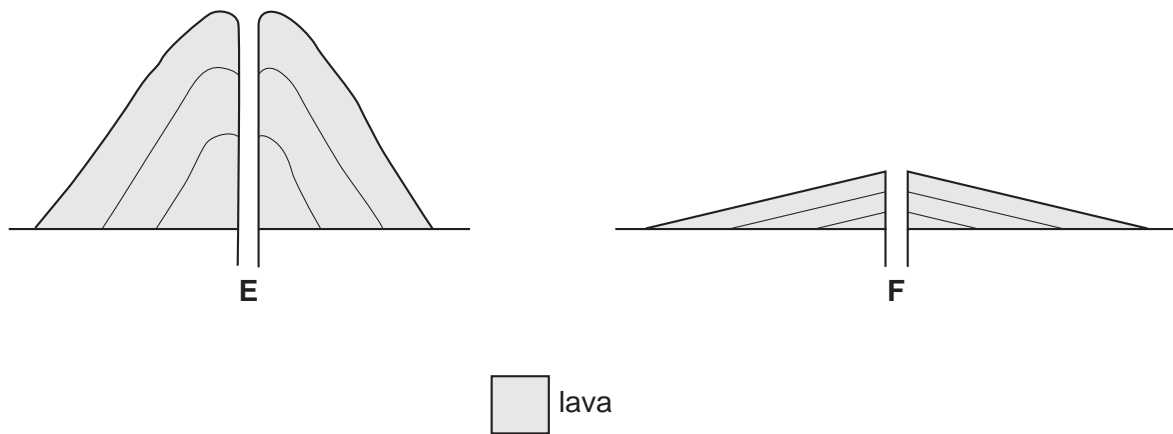

Fig. 4

- (i) Describe the differences in the shape of the two volcanoes. [2]
- (ii) Describe differences in the lava, which explains the answer you have given in (b)(i). [2]
- (iii) Briefly describe what causes a volcano to erupt. [2]
- (c) Describe ways in which both high fold mountains and active volcanoes may cause problems for people who live in areas where they are located. [4,4]

- 4 (a) Fig. 5 shows three weather instruments (**A**, **B** and **C**).

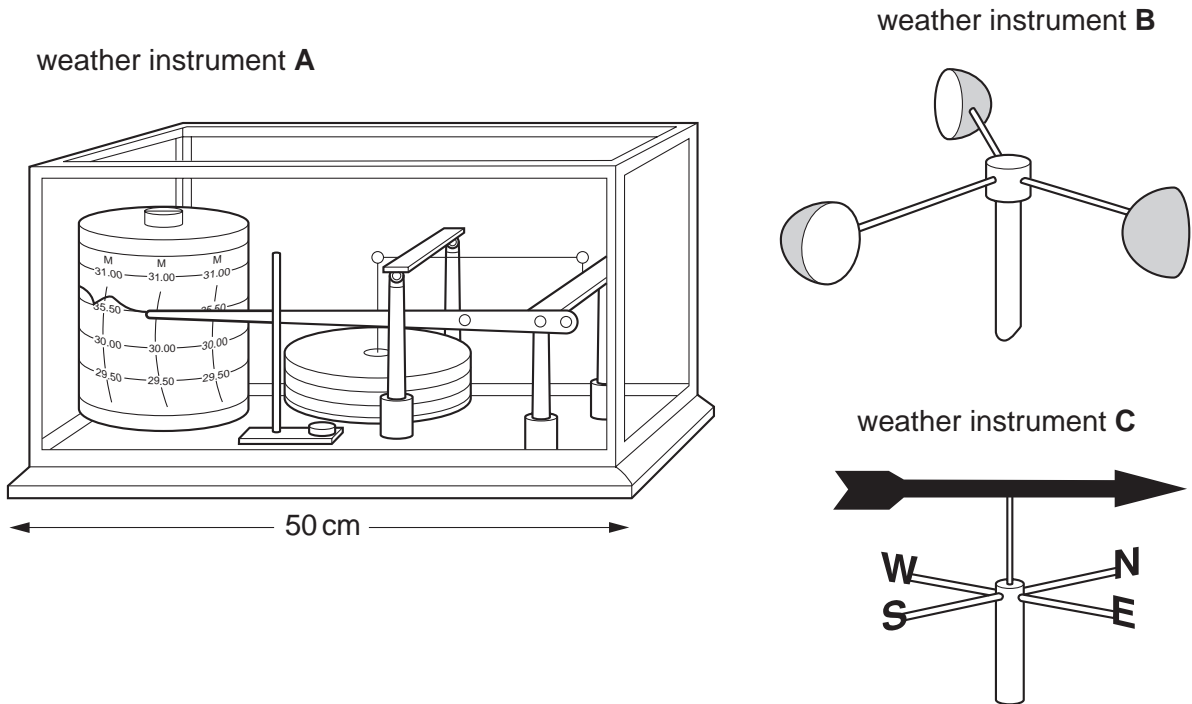

Fig. 5

- (i) Write down **A**, **B** and **C** and against each letter name the weather instrument shown. [3]
- (ii) How does weather instrument **A** work? [3]
- (iii) Weather instruments **B** and **C** are used to record different features of the wind.
Write down **B** and **C** and against each letter state what each of these weather instruments is used for. [2]
- (iv) Where are weather instruments **B** and **C** sited at a weather station? Give a reason for your answer. [2]

(Question 4 continues on p8.)

(b) Fig. 6 shows the location of tropical deserts in the world.

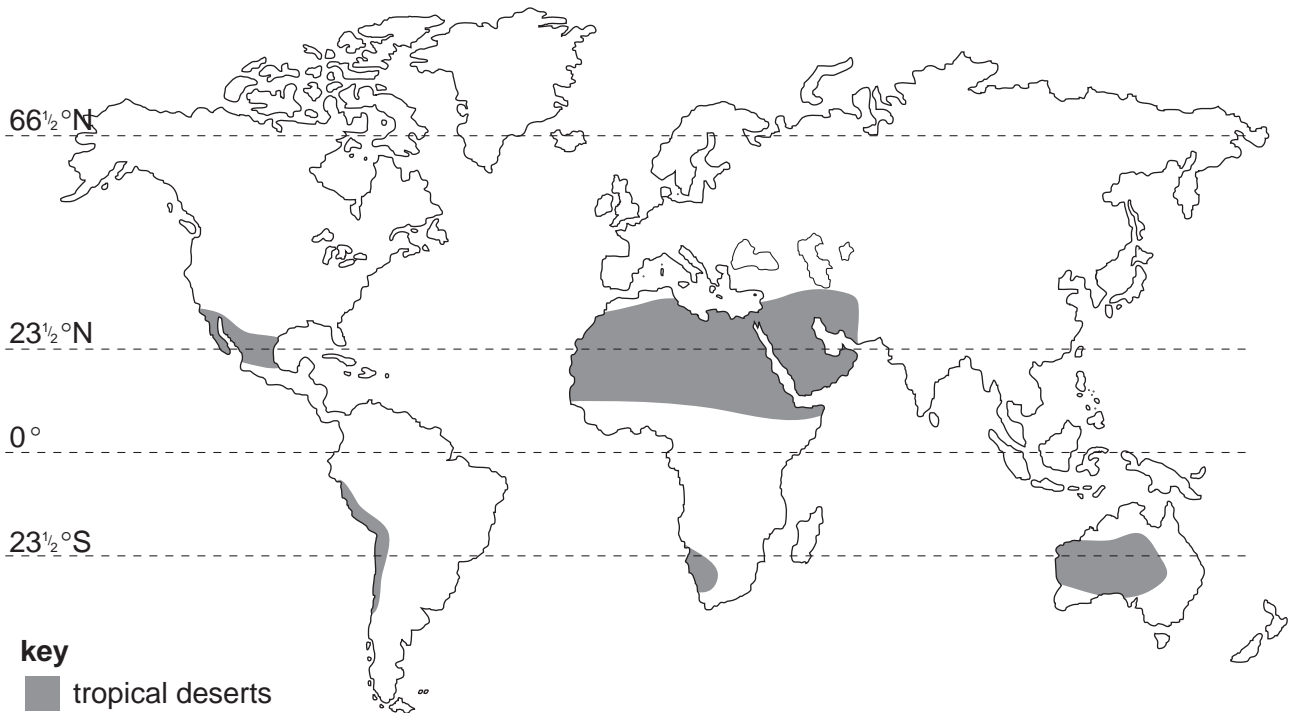

Fig. 6
Distribution of the world's tropical deserts

- (i) Use Fig. 6 to describe where tropical deserts are generally found. [2]
- (ii) State **two** important facts about *each* of temperature and rainfall received in a tropical desert. [2,2]
- (iii) Describe how natural vegetation in a tropical desert region is adapted to the rainfall conditions you have given in (b)(ii). [2]
- (c) By means of a labelled sketch diagram **only**, explain how an oasis is formed. [3]

- (d) Fig. 7 shows a large rock on the surface of a tropical desert which is being weathered by a process of physical (mechanical) weathering.

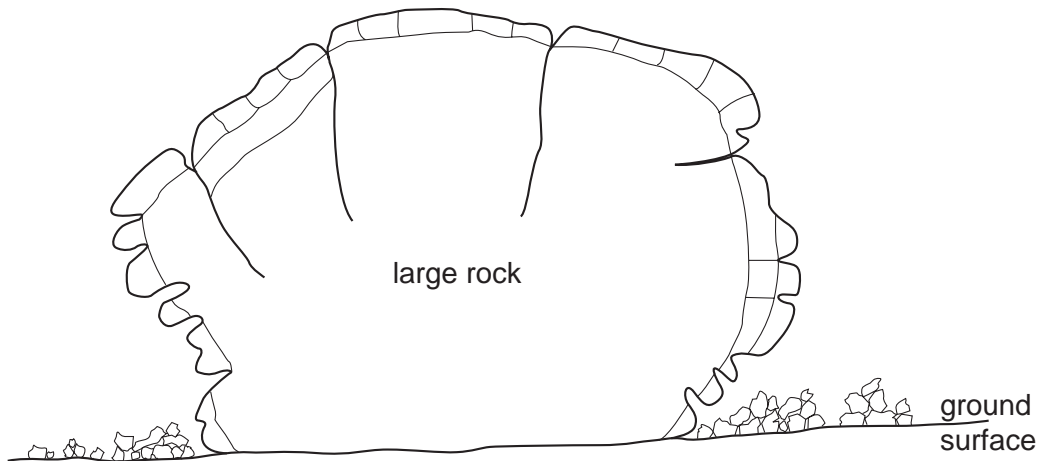

Fig. 7

- (i) Name the type of physical weathering shown. [1]
- (ii) How is the rock shown being weathered? [2]
- (iii) Describe the results of this weathering process. [1]

- 5 (a) Fig. 8 shows a system of small-scale subsistence farming, growing rice.

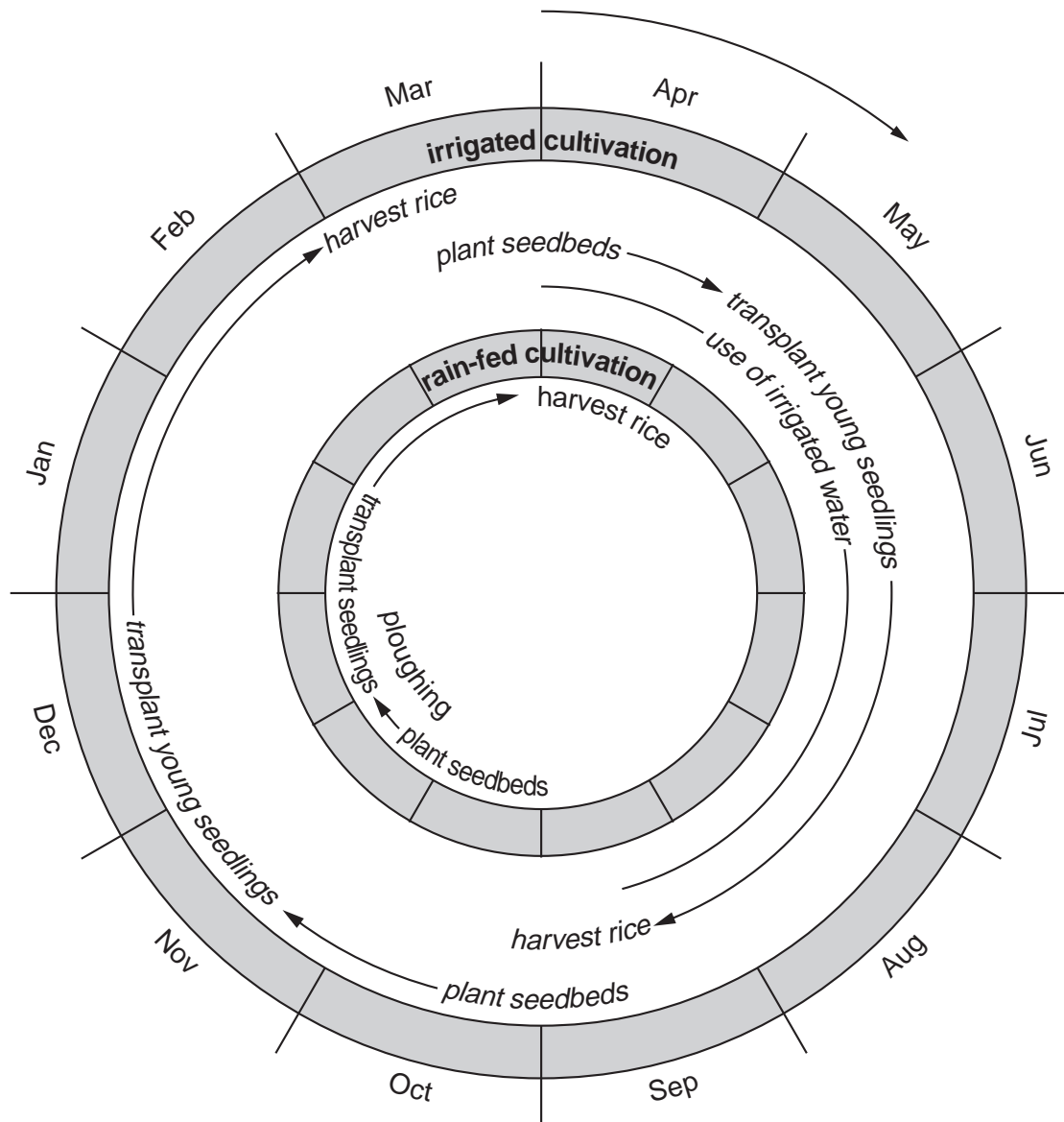

Fig. 8

- (i) What is 'subsistence farming'? [2]
- (ii) Describe the following processes referred to on Fig. 8;
- A ploughing,
- B planting,
- C harvesting. [3]
- (iii) Why are traditional (older) methods of ploughing, planting and harvesting still used on subsistence farms in many parts of the world? [2]
- (iv) How does Fig. 8 show that irrigation can make a difference to subsistence farmers growing rice? [2]
- (v) Describe **four** other ways in which subsistence farmers can grow more food, apart from using irrigation water. [4]

- (b) Now look at the newspaper extract (Fig. 9) which is about food supply.

Action needed now to avert disaster

Today the world will gain another 230 000 people. Is it possible to provide for them all? There is no reason why anyone should go hungry today. The problem is poverty and the unequal distribution of wealth in the world rather than the technology to produce enough food. There is more than enough food to go round. Thirty years ago the global food supply was the equivalent of 2 360 calories a day per person; today it is 2 740 calories. Food supplies are expected to outstrip population growth for at least ten more years.

But the population explosion is mainly taking place in the developing world, where two billion people go hungry every day.

Fig. 9

- (i) What does the newspaper extract suggest about
- A** the length of time that the world will provide enough food for all its people,
 - B** reasons for shortages of food in parts of the world,
 - C** the amount of food now available? [5]
- (ii) From studies you have made, give reasons, **excluding** those mentioned in the newspaper extract, which may lead to food shortages in certain world areas. [4]
- (iii) Why do some parts of the world produce more food than they need? [3]

- 6 (a) Fig. 10 shows the employment structure in a developed country.

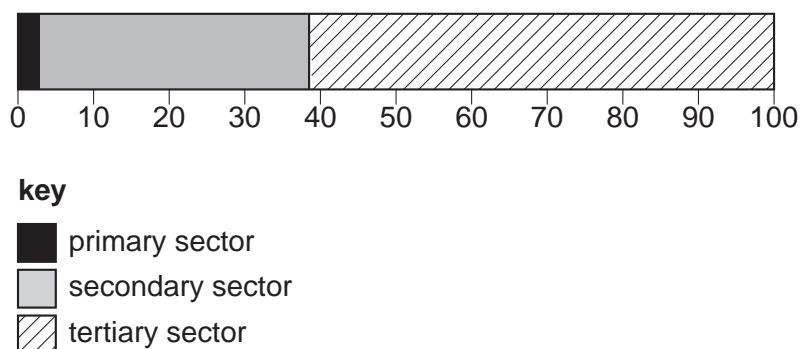

Fig. 10
Percentage of employed population in a developed country

- (i) What percentage of the working population is employed in the tertiary sector? [1]
- (ii) Give **one** reason why only a small percentage is employed in the primary sector. [1]
- (iii) How would you expect the employment structure of a developing country to be different from that shown in Fig. 10? [3]
- (iv) Suggest reasons for the differences you have given in (a)(iii). [3]
- (v) With reference to **two** named examples, explain what is meant by the tertiary sector. [3]
- (b) (i) Name **one** area important for high technology industries. [1]
- (ii) Explain how **three** of the factors listed below have influenced the development of high technology industries in the area you have named in (b)(i);
- labour,
 - transport,
 - research and development,
 - site factors. [3]
- (iii) Why are high technology industries referred to as 'footloose industries'? [1]
- (c) Global warming is one of the most serious problems facing the world in the 21st century. With the help of data from Fig. 11 (Insert 2) and with reference to other information you may know:
- (i) explain what causes global warming, [3]
- (ii) state which parts of the world, shown on Fig. 11, are expected to have increases in temperature of more than 6 °C by 2100, [2]
- (iii) explain why it is important to control global warming. [4]

Copyright Acknowledgements:

Figure 2
Photograph A
Figure 3b
Figure 9
Figure 11

M. Pacione. *Geography*. Published by The Geographical Association. © United Nations.
Photograph by R. Howarth.
© *The Guardian*.
© *The Guardian*.
© *The Guardian*.

Cambridge International Examinations has made every effort to trace copyright holders, but if we have inadvertently overlooked any we will be pleased to make the necessary arrangements at the first opportunity.