

CANDIDATE  
NAME

--

CENTRE  
NUMBER

--	--	--	--	--

CANDIDATE  
NUMBER

--	--	--	--

**GEOGRAPHY**

**0460/22**

Paper 2

**May/June 2018**

**1 hour 30 minutes**

Candidates answer on the Question Paper.

Additional Materials:      Ruler  
   Protractor  
   Plain paper  
   Calculator

1:50 000 Survey Map Extract is enclosed with this Question Paper.

**READ THESE INSTRUCTIONS FIRST**

Write your Centre number, candidate number and name in the spaces provided.

Write in dark blue or black pen.

You may use an HB pencil for any diagrams or graphs.

Do not use staples, paper clips, glue or correction fluid.

**DO NOT WRITE IN ANY BARCODES.**

Write your answer to each question in the space provided.

If additional space is required, you should use the lined pages at the end of the booklet. The question number(s) must be clearly shown.

Answer **all** questions.

The Insert contains Figs. 3.1 and 3.2 for Question 3.

The Survey Map Extract and the Insert are **not** required by the Examiner.

Sketch maps and diagrams should be drawn whenever they serve to illustrate an answer.

At the end of the examination, fasten all your work securely together.

The number of marks is given in brackets [ ] at the end of each question or part question.

Definitions

MEDCs – More Economically Developed Countries

LEDCs – Less Economically Developed Countries

This syllabus is approved for use in England, Wales and Northern Ireland as a Cambridge International Level 1/Level 2 Certificate.

This document consists of **20** printed pages and **1** Insert.

1 Study the map extract for Vinstra, Norway. The scale is 1:50 000.

(a) Fig. 1.1 shows some of the features in the north of the map extract. Study Fig. 1.1 and the map extract, and answer the questions below.

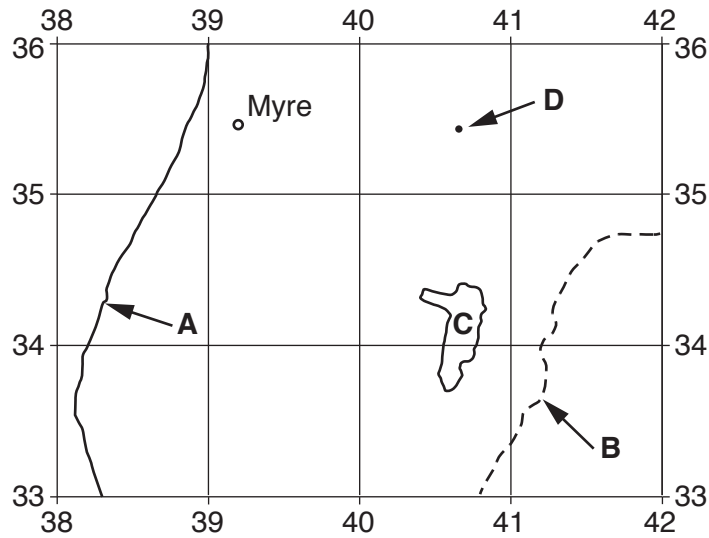

Fig. 1.1

(i) Identify the type of road at **A**.

..... [1]

(ii) Identify feature **B**.

..... [1]

(iii) Identify feature **C**.

..... [1]

(iv) What is the height above sea level at **D**?

..... metres [1]

(v) What is the six-figure grid reference of the house at Myre, shown on Fig. 1.1? Tick **one** correct answer below.

	Tick (✓)
382355	
355392	
408366	
391354	
391355	

[2]

- (b) Fig. 1.2 is a cross section along northing 345 from the western edge of the map at 340345 to 400345, passing through the summit of the mountain Teigkampen.

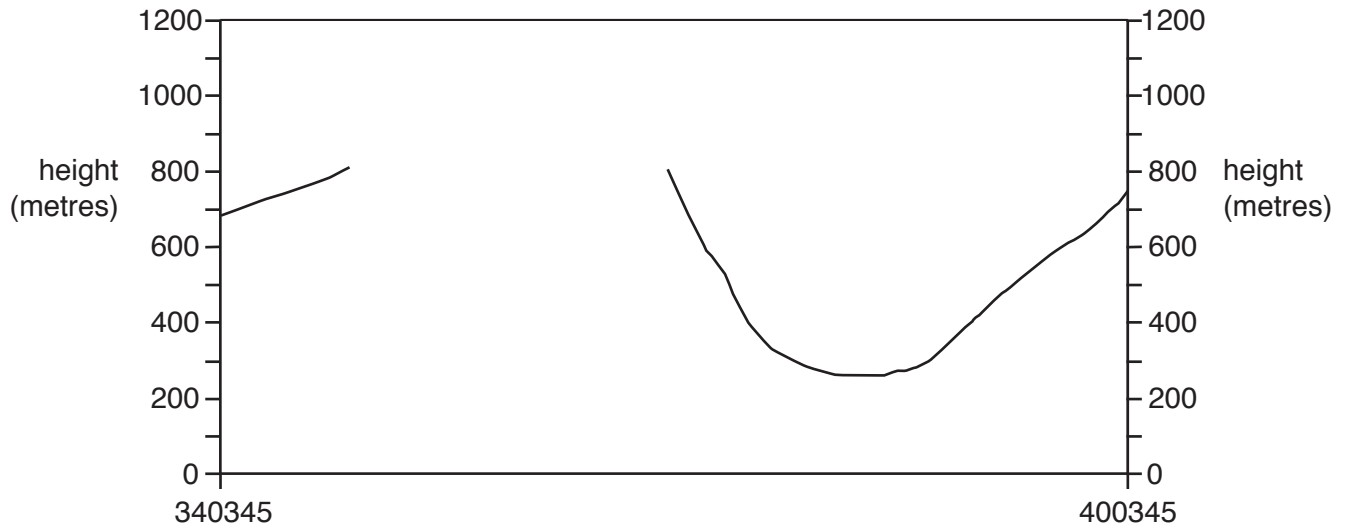

**Fig. 1.2**

- (i) Using the map, **complete the cross section** on Fig. 1.2. [2]
- (ii) On Fig. 1.2, **use a labelled arrow** to show the position of the railway. [1]
- (iii) On Fig. 1.2, **use a labelled arrow** to show the position of a marked footpath. [1]

(c) Using map evidence, give reasons for the growth of the main area of settlement on the map at Vinstra.

.....  
.....  
.....  
.....  
.....  
.....  
.....  
.....  
.....  
.....  
.....

[4]

(d) Fig. 1.3 shows part of the valley of the river Vinstra in the south west of the map extract.

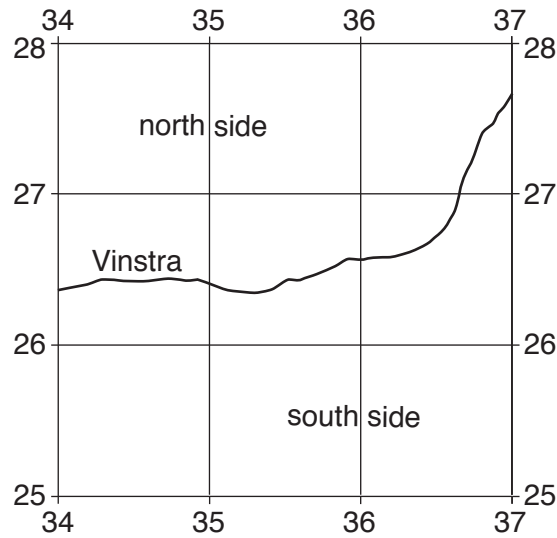

Fig. 1.3

Compare the following features on the north side of the valley and the south side of the valley:

roads

.....  
.....  
.....  
.....

settlement

.....  
.....  
.....  
.....

land use

.....  
.....  
.....  
.....

relief.

.....  
.....  
.....  
.....

[6]

[Total: 20]

2 Fig. 2.1 shows the five countries expected to have the largest populations by the year 2100.

	China	India	Indonesia	Nigeria	USA
population in 2016 (billions)	1.37	1.28	0.26	0.18	0.32
estimated population in 2100 (billions)	1.09	1.55	0.36	0.91	0.46
birth rate in 2016 (per 1000)	12.49	19.55	16.72	37.64	12.49
migration in 2016 (per 1000)	-0.44	-0.04	-1.16	-0.22	+3.86

Fig. 2.1

(a) (i) Use information from Fig. 2.1 to **plot the estimated population** of Indonesia in 2100 on Fig. 2.2 below. [1]

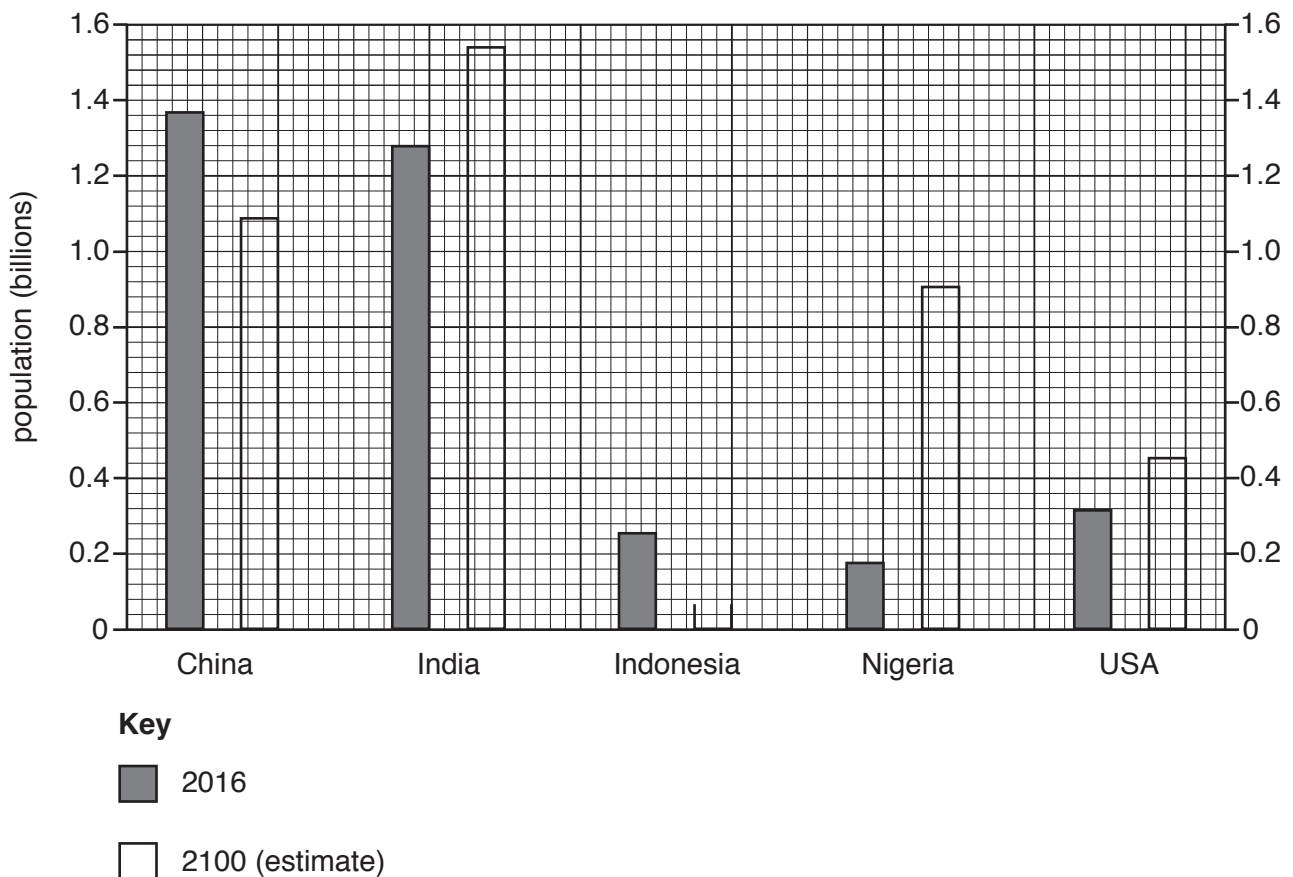

Fig. 2.2

(ii) Which country shown on Fig. 2.2 is expected to have a population decrease between 2016 and 2100?

..... [1]

(iii) Using Fig. 2.1, calculate the estimated increase in the population of USA between 2016 and 2100.

..... billion [1]

(iv) Which country shown on Figs. 2.1 and 2.2:

had the largest population in 2016

.....

is expected to have the largest population in 2100?

..... [1]

(b) Which country shown on Fig. 2.1 is expected to have the greatest increase in population between 2016 and 2100? Use information from Fig. 2.1 to suggest the main reason for this.

Country .....

Reason .....

..... [2]

(c) (i) Is migration an important factor in the growth in population of the countries shown on Fig. 2.1? Use information from Fig. 2.1 to support your answer.

.....

.....

..... [1]

(ii) Give **one** other population statistic, not shown on Fig. 2.1, which would help explain these population changes.

..... [1]

[Total: 8]

3 (a) Study Fig. 3.1 (Insert), which is a photograph showing part of an urban area.

Suggest which urban zone is shown in the photograph and give **four** reasons for your choice.

Urban zone

.....

Reasons

1 .....

.....

2 .....

.....

3 .....

.....

4 .....

..... [5]



(b) Study Fig. 3.2 (Insert), which is a photograph showing the industrial zone of an urban area. Using evidence from the photograph, explain why industry has developed here.

.....

.....

.....

.....

.....

.....

.....

.....

.....

.....

.....

.....

[3]

[Total: 8]

4 (a) Fig. 4.1 shows a cross section through an area affected by an earthquake.

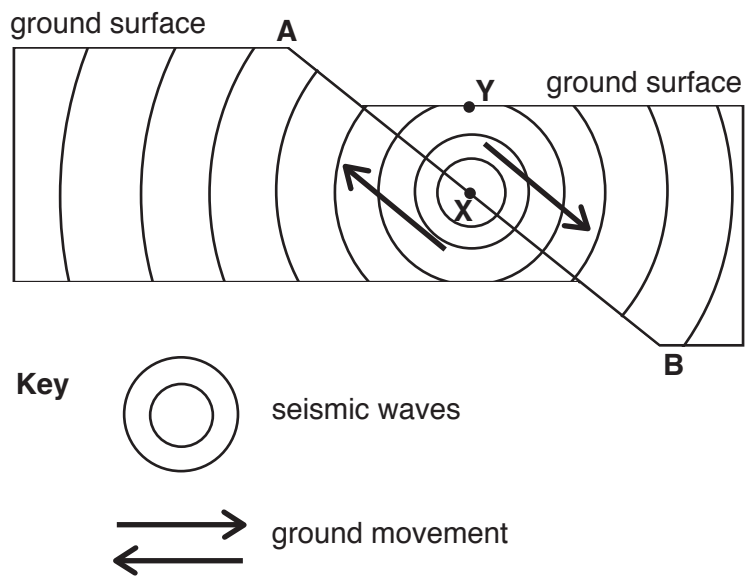

Not to scale

Fig. 4.1

(i) Identify points X and Y shown on Fig. 4.1.

X .....

Y .....

[2]

(ii) Describe what happened along line A – B to cause an earthquake.

.....  
 .....  
 .....[1]

(b) Fig. 4.2 gives information about an earthquake at Bam in Iran.

An earthquake occurred at Bam in south east Iran on December 26, 2003 at 05:26. More than 40 000 people were killed, 50 000 were injured and 100 000 became homeless.

The Arg-e-Bam, the largest mud-brick building in the world, which was about 2000 years old, was almost totally destroyed in the earthquake.

**Fig. 4.2**

Using Fig. 4.2, suggest the importance of the following on the effects of the earthquake:

(i) the time of day

.....  
.....[1]

(ii) the building materials of the Arg-e-Bam.

.....  
.....[1]

(c) Using Fig. 4.2, suggest when the last major earthquake occurred at Bam before 2003.

.....  
.....[1]

(d) Fig. 4.3 is a map showing the intensity of the Bam earthquake. Fig. 4.4 describes the different intensity values.

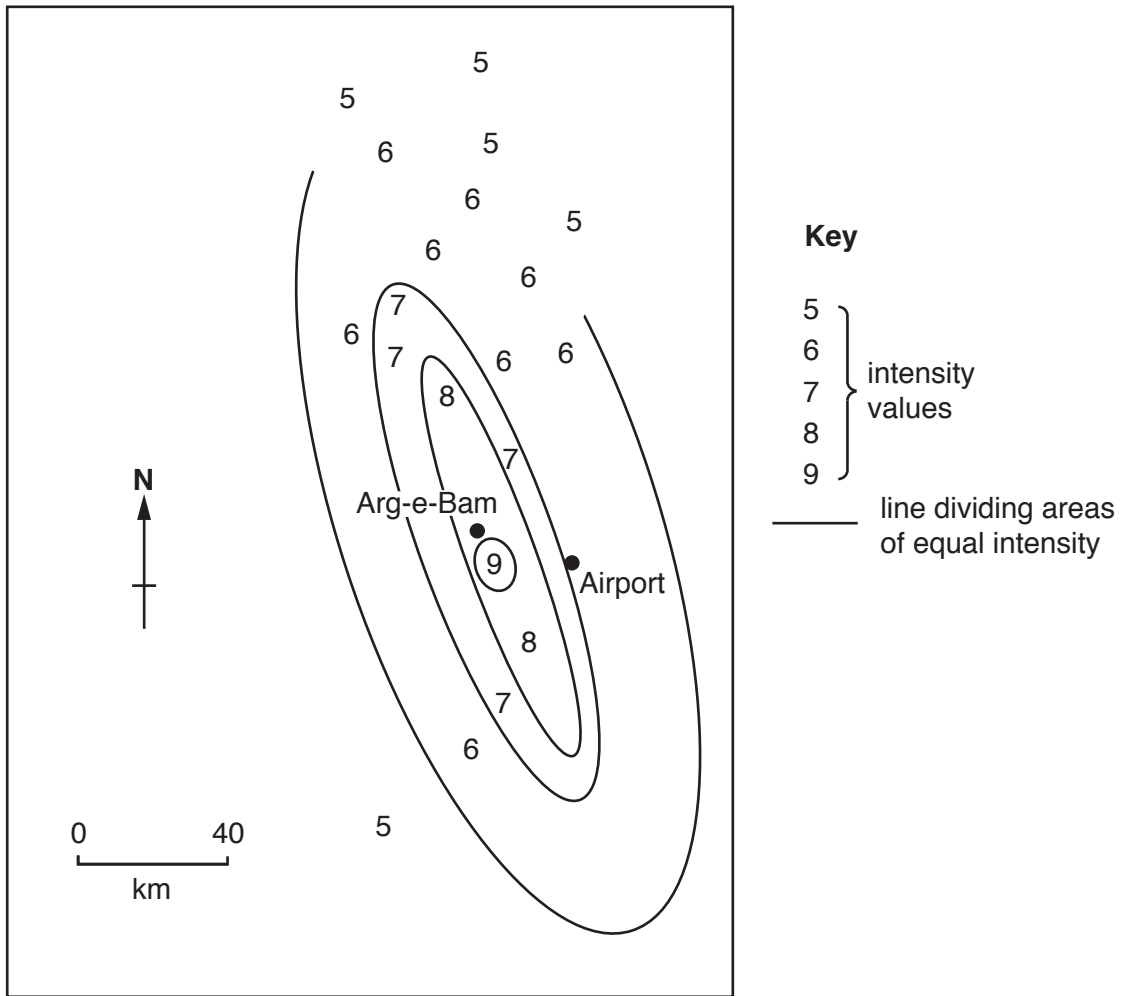

Fig. 4.3

Intensity value	Description of effects
5	Felt by nearly everyone. Sleepers wake up. Some windows broken. Unstable objects overturned. Clocks may stop.
6	Felt by everyone, many people frightened. Some plaster falls from walls. Damage slight.
7	Difficult to stand up. People run outdoors. Walls crack.
8	Partial collapse of buildings. Chimneys fall. Damage great in poorly constructed buildings.
9	Damage considerable in well-designed structures, with partial collapse. Buildings shifted off foundations.

**Fig. 4.4**

(i) **Complete the line** of equal intensity in the north of Fig. 4.3. [1]

(ii) Using Figs. 4.3 and 4.4, describe the effects of the earthquake on the buildings at the airport.

.....  
 .....[1]

[Total: 8]

5 Study Fig. 5.1, which shows instruments **A**, **B** and **C**, which are used to measure the weather.

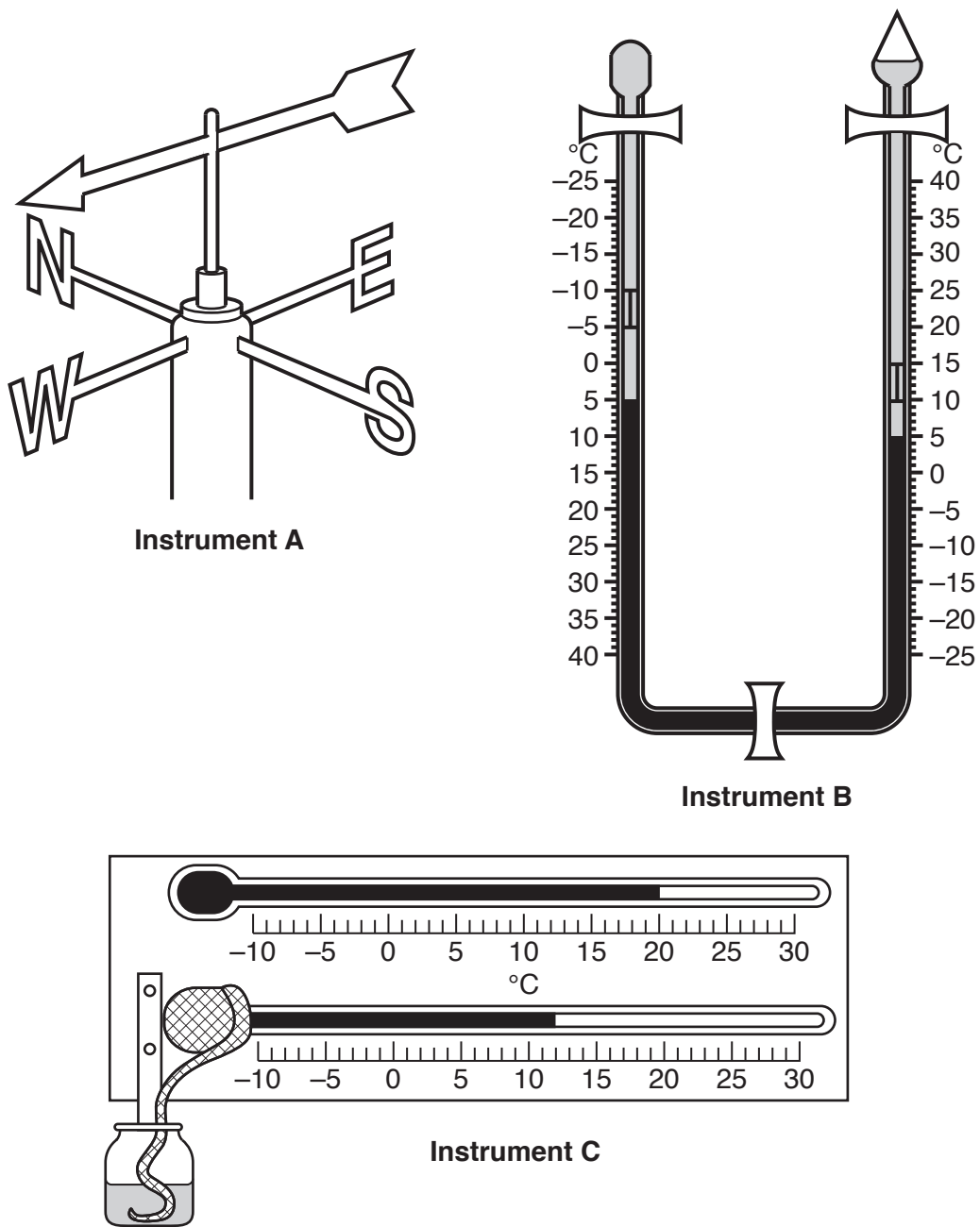

Fig. 5.1

(a) Name the three weather instruments.

(i) Instrument **A** .....

(ii) Instrument **B** .....

(iii) Instrument **C** .....

[3]

(b) Using Instrument **A**, state the wind direction.

..... [1]

(c) Using the information shown on Instrument **B**, state the:

(i) present temperature

..... [1]

(ii) maximum temperature since the instrument was reset

..... [1]

(iii) minimum temperature since the instrument was reset.

..... [1]

(d) Do the readings shown on Instrument **C** show that the air is saturated (relative humidity 100%)? Explain your answer.

.....  
.....  
..... [1]

[Total: 8]

- 6 Figs. 6.1 and 6.2 give information about Kenya, one of the main manufacturing countries in East Africa.

**Kenya – location, imports and export routes**

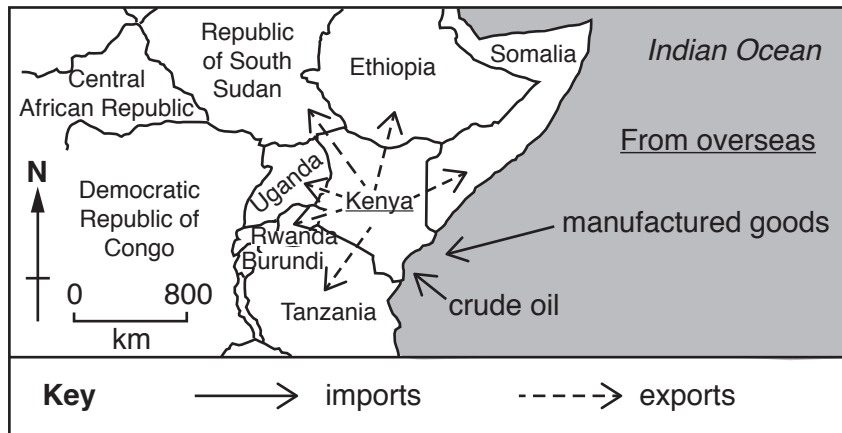

**Fig. 6.1**

**Kenya – manufacturing centres and materials produced within the country**

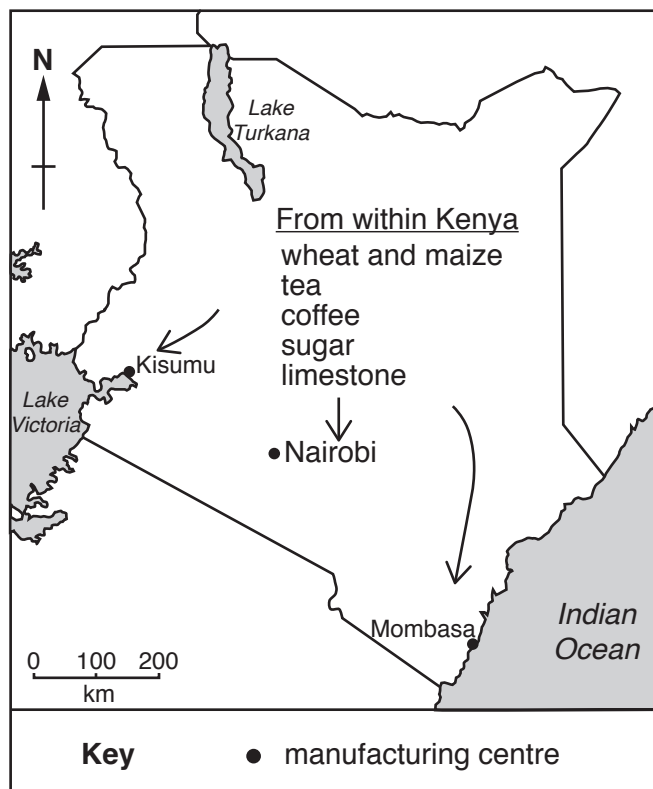

**Fig. 6.2**



(a) Using Figs. 6.1 and 6.2, suggest **three** advantages of Kenya for the development of manufacturing industry.

- 1 .....
- .....
- .....
- 2 .....
- .....
- .....
- 3 .....
- .....
- .....[3]

(b) Using Figs. 6.1 and 6.2, suggest **one** disadvantage of Kenya for the development of manufacturing industry.

- .....
- .....
- .....[1]

(c) Using Figs. 6.1 and 6.2, suggest why an oil refinery is located at Mombasa.

- .....
- .....
- .....
- .....[2]

(d) Fig. 6.3 shows the employment structure of Kenya.

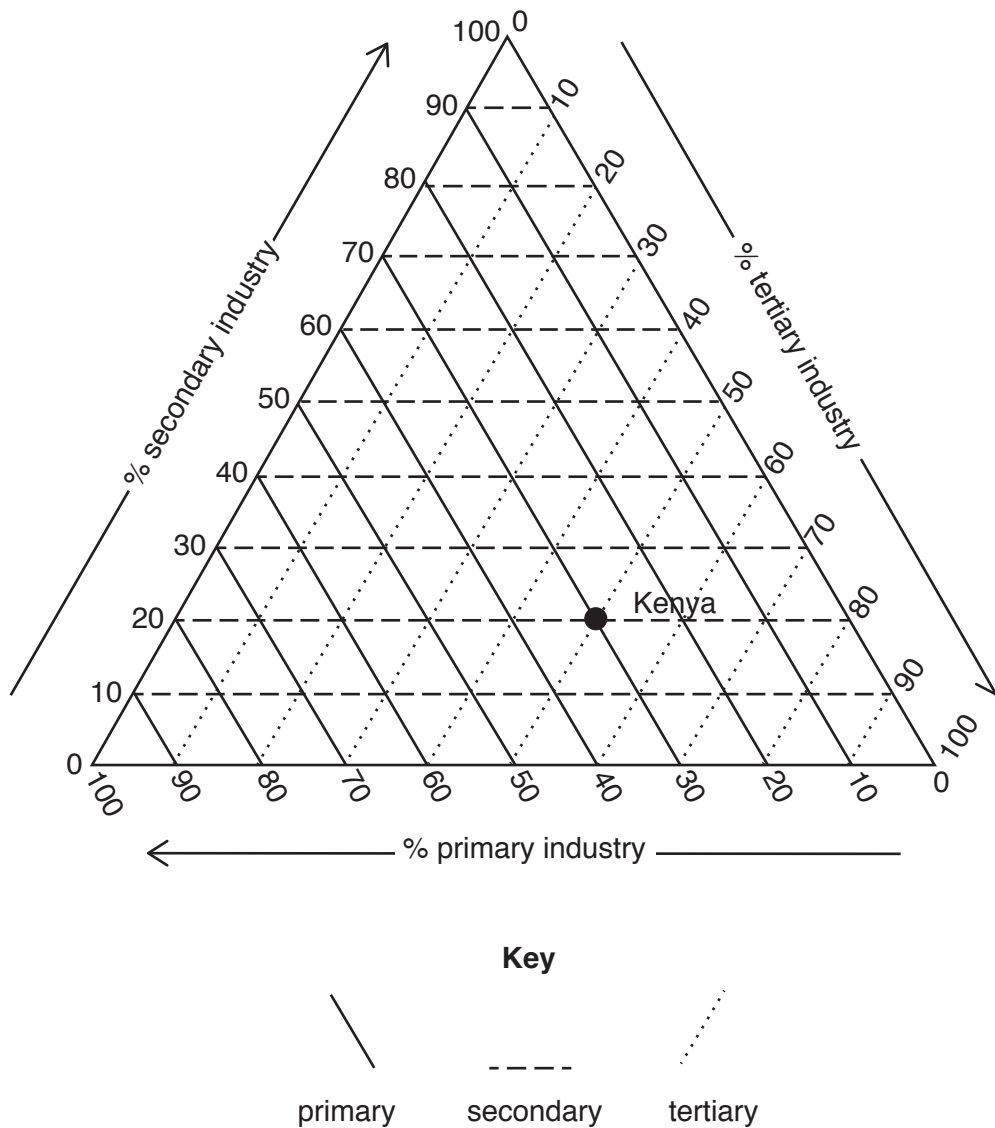

**Fig. 6.3**

What percentage of Kenya's employment is in:

(i) secondary industry

..... %

[1]

(ii) tertiary industry?

..... %

[1]

[Total: 8]



